

SUPPLY PDP 42"- 50"

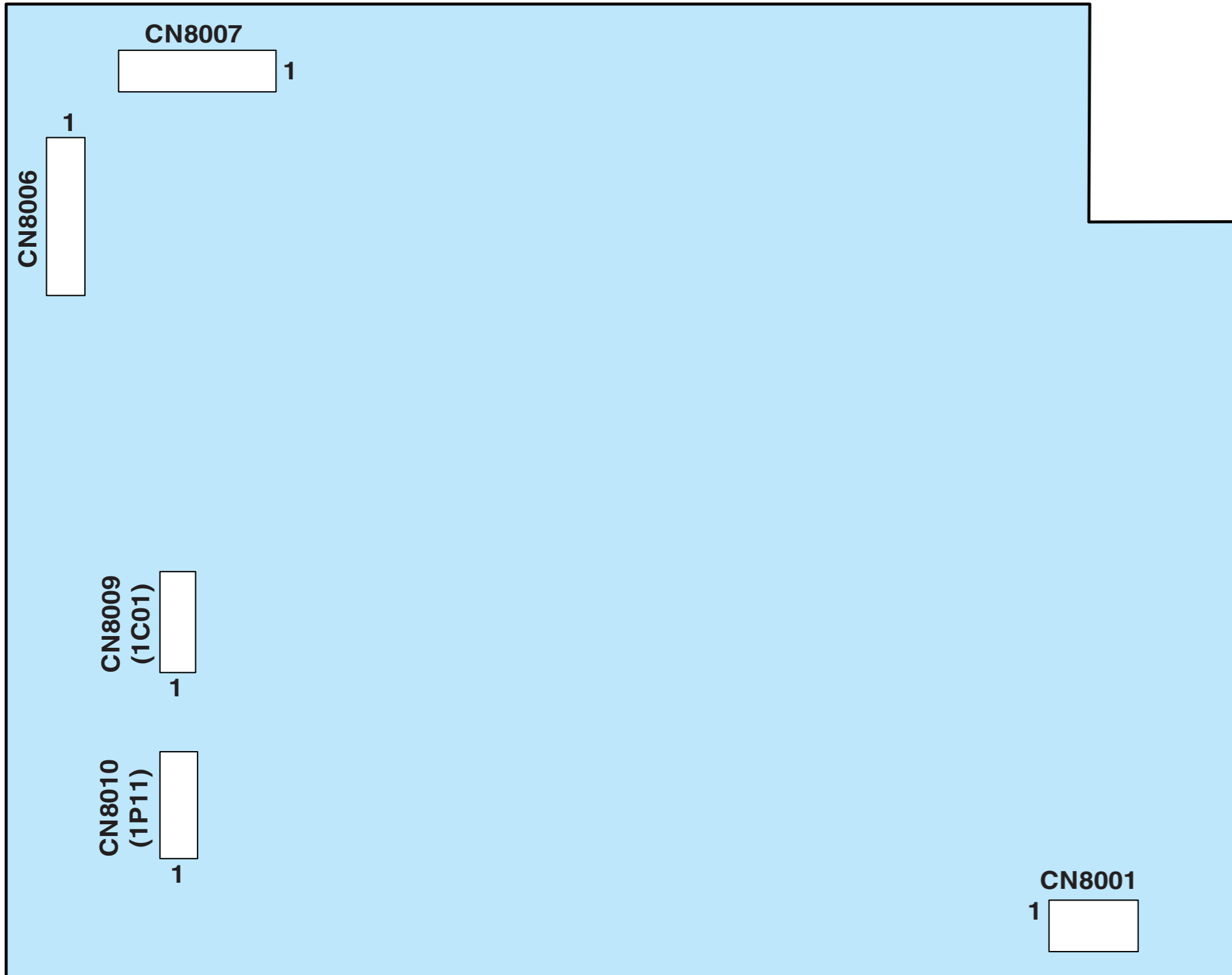

CN8001

- 1 AC_L
- 2 AC_N

CN8009

(1C01)

- 1 VSND_NEG
- 2 VSND_POS
- 3 GND_SND
- 4 5Vstb
- 5 5Vsw
- 6 5Vsw
- 7 GND_SSP
- 8 GND_SSP
- 9 GND_SSP

CN8010

(1P11)

- 1 N.C
- 2 Power_ok
- 3 N.C
- 4 GND_SSP
- 5 N.C
- 6 STANDBY
- 7 N.C
- 8 12Vssb

CN8006

- 1 Vg
- 2 GND_SSP
- 3 GND_SSP
- 4 GND_SSP
- 5 Vs
- 6 Vs

CN8007

- 1 Vg
- 2 GND_SSP
- 3 GND_SSP
- 4 Vs
- 5 Vs

B03A TUNER IF & DEMODULATOR

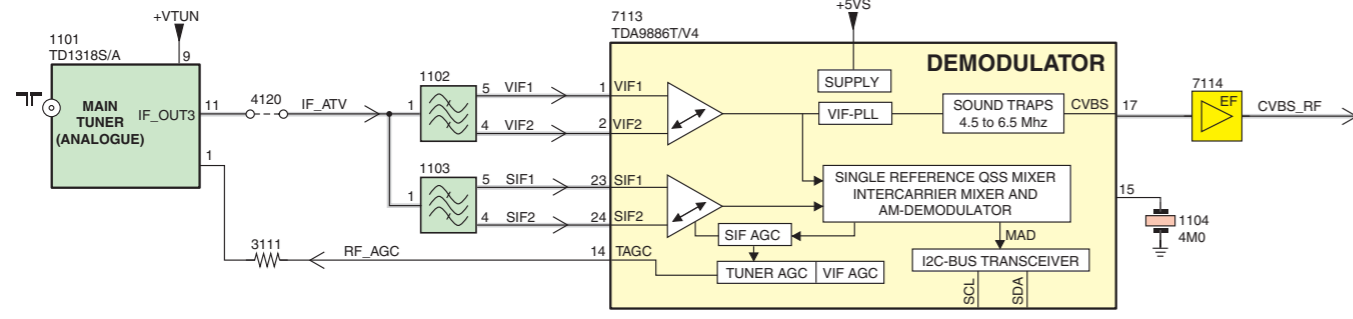

B04B VIDEO PROCESSOR

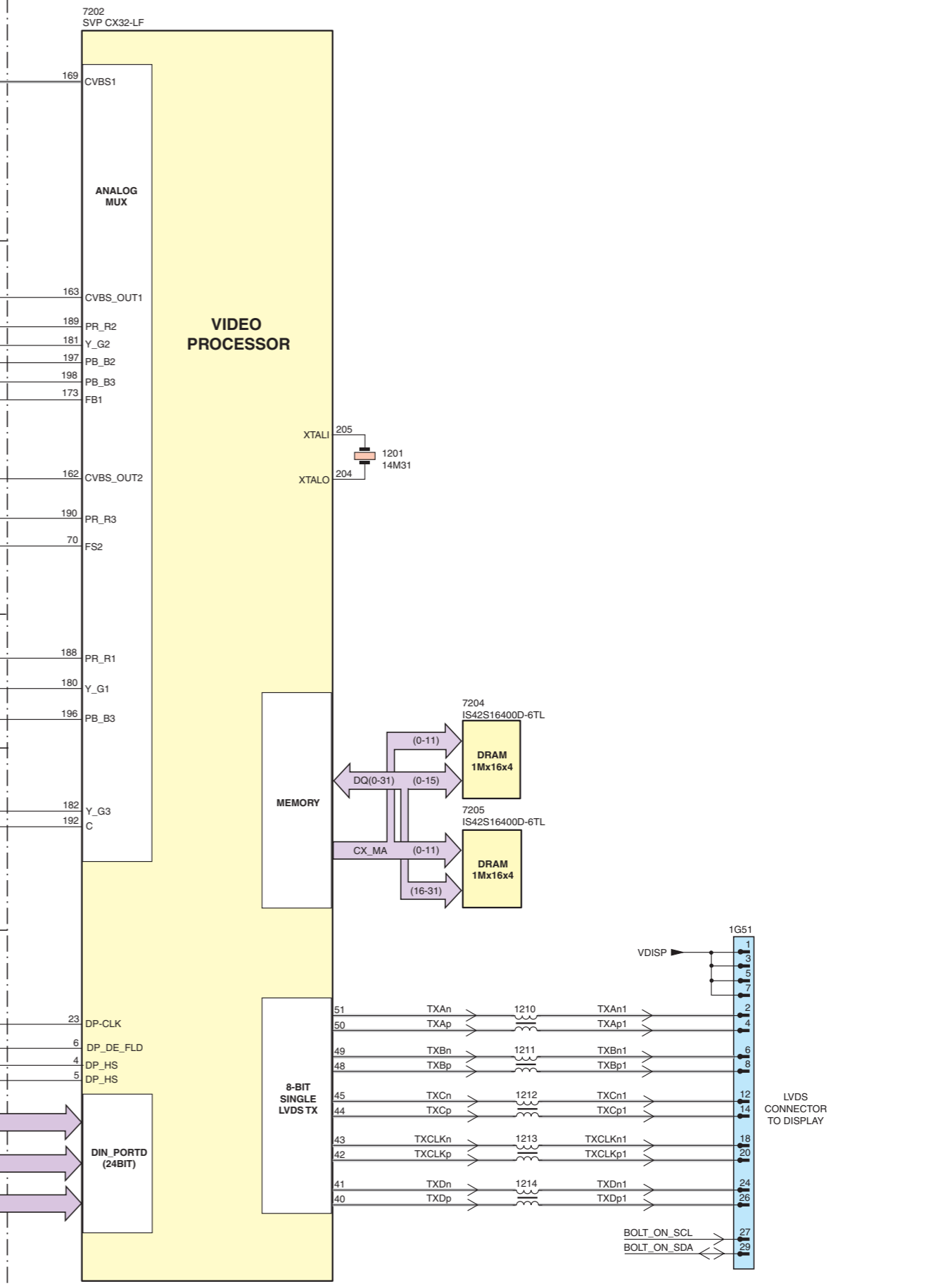

B06B IO - SCART 1 & 2

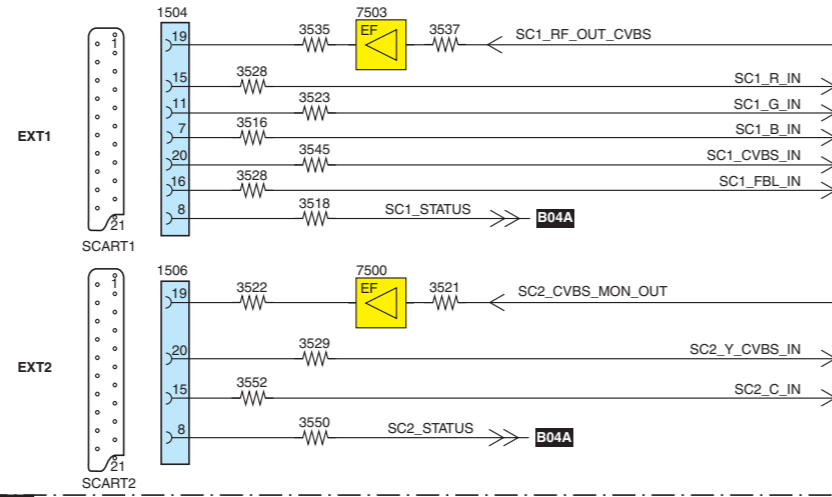

B06A YPBPR & REAR IO

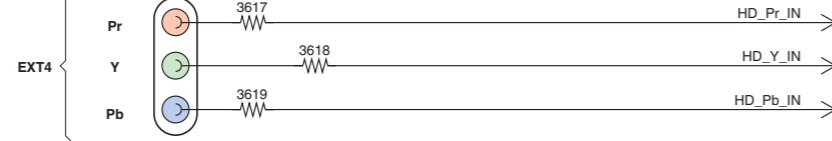

D SIDE FACING SIDE AV

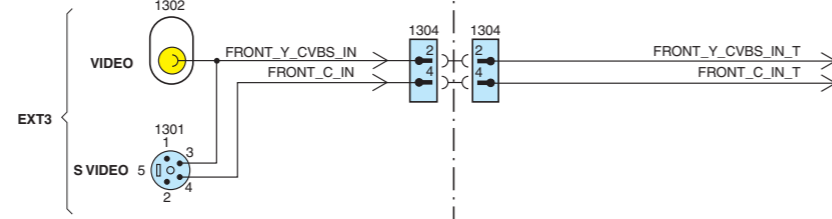

B04A MICROPROCESSOR

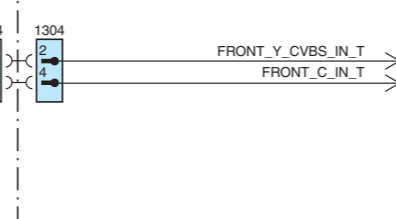

B06C HDMI

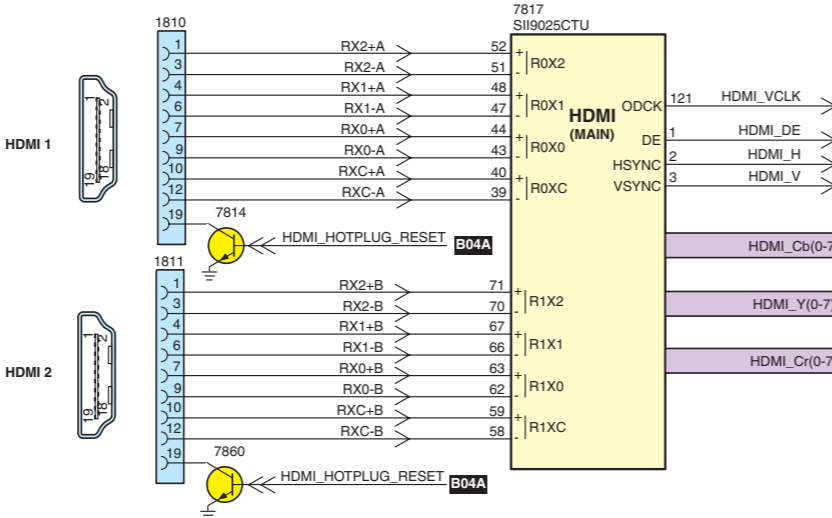

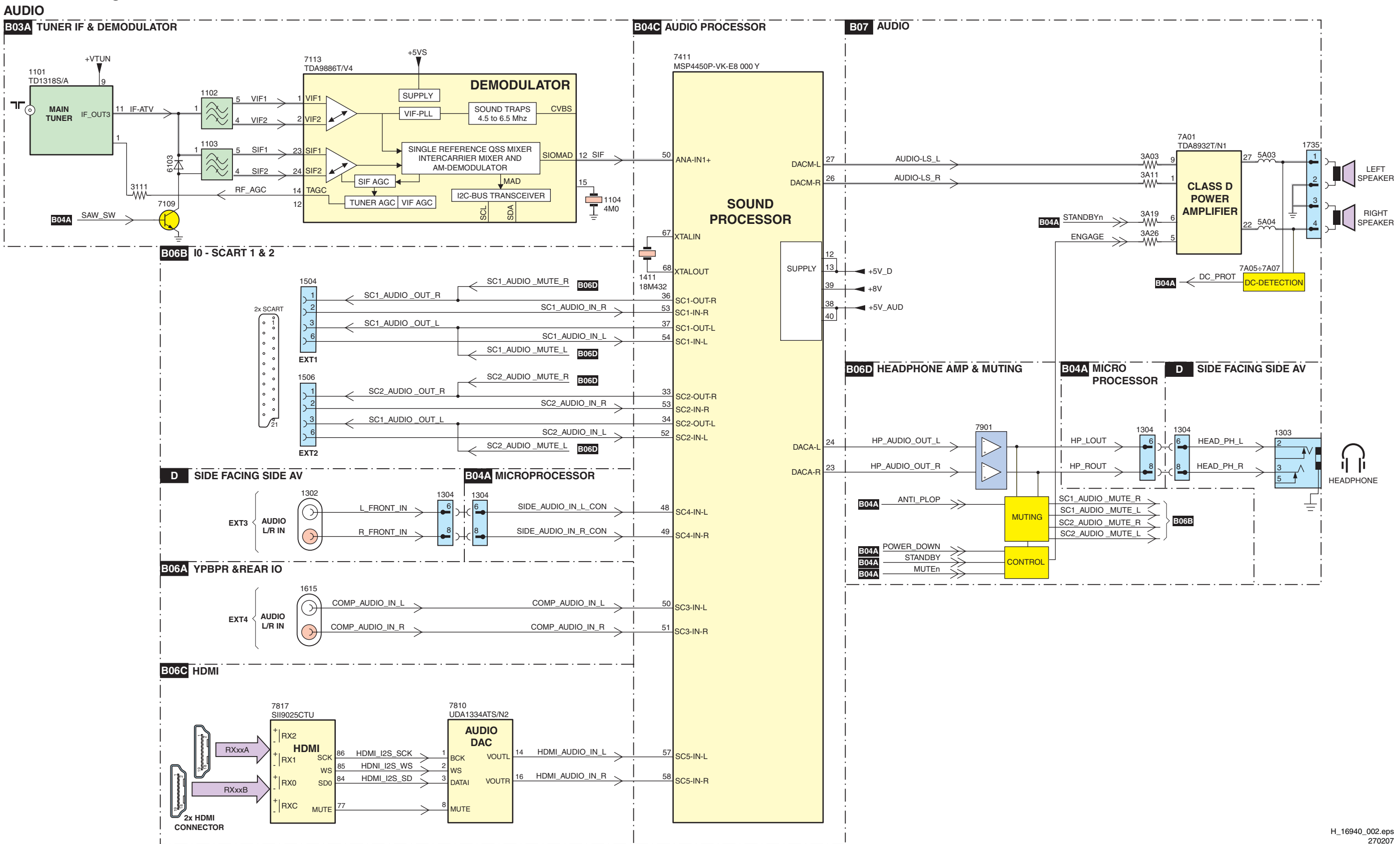

CONTROL & CLOCK SIGNALS

B04B VIDEO PROCESSOR

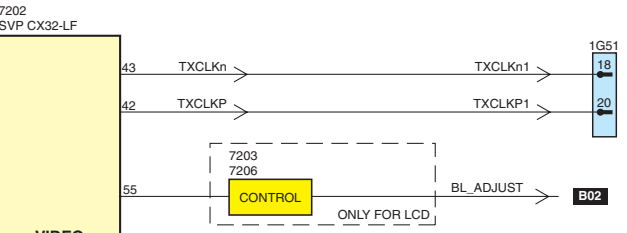
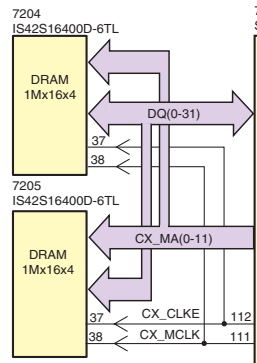

B06C HDMI

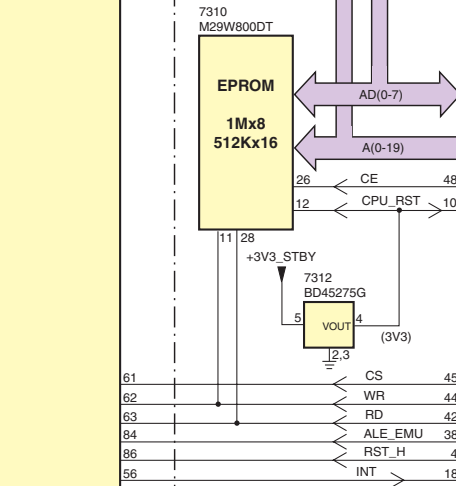
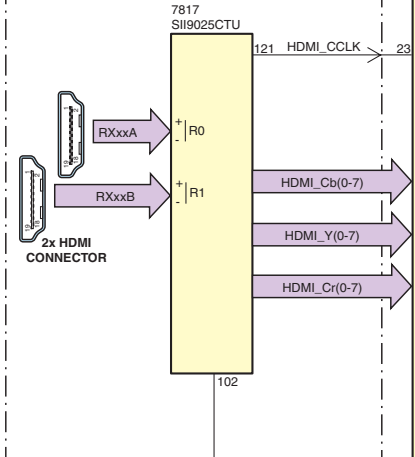

E KEYBOARD CONTROL

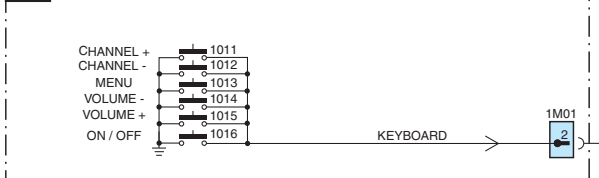

J IR/LED/LIGHT-SENSOR

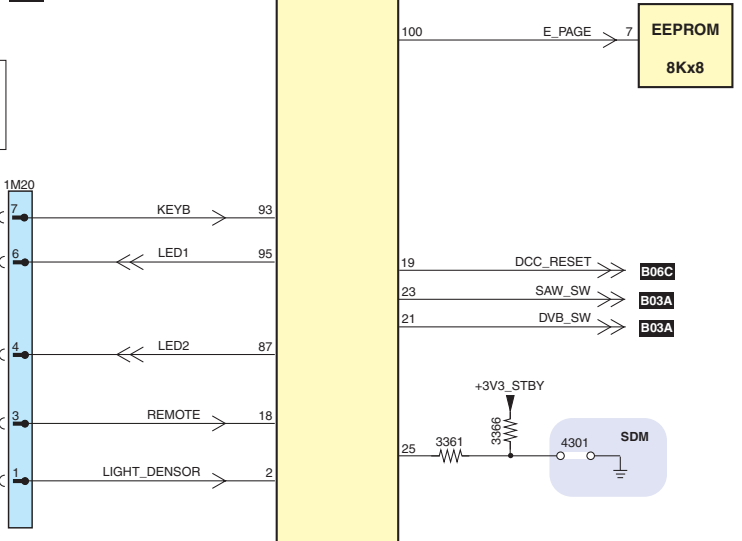
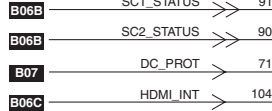
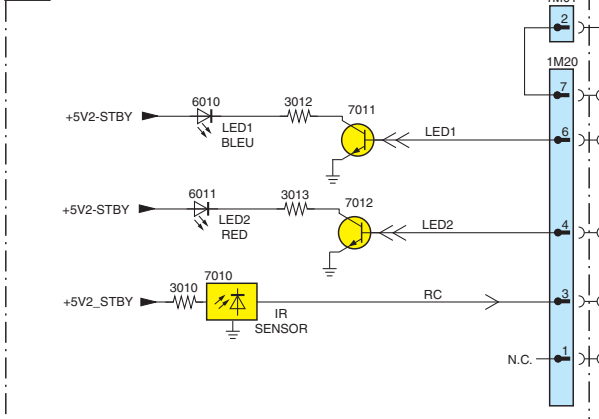

PC **B04A MICROPROCESSOR** **B06C HDMI** **B04C AUDIO PROCESSOR** **B04B VIDEOPROCESSOR** **B03A TUNER IF & DEMODULATOR**

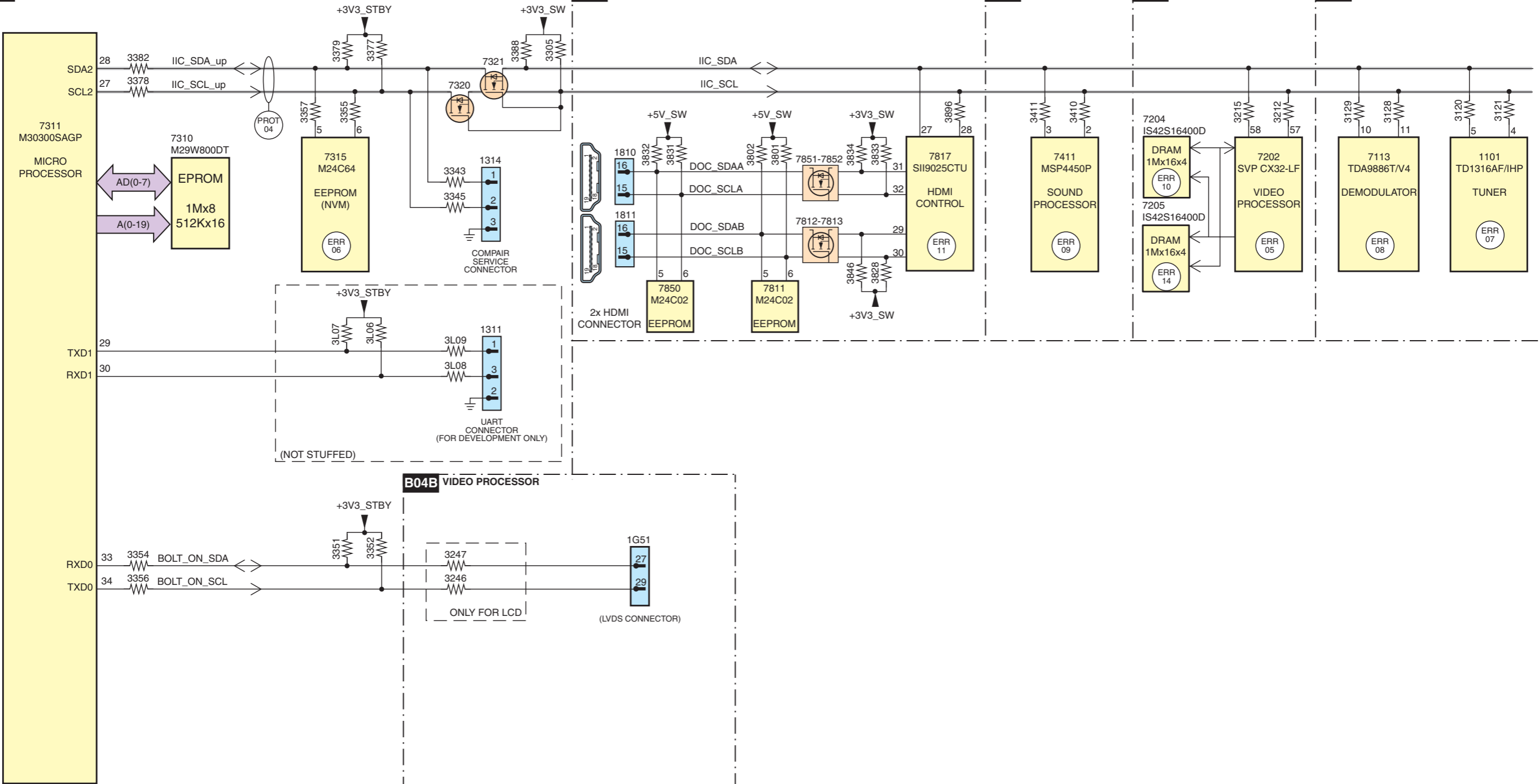

(NOT STUFFED)

ONLY FOR LCD

SUPPLY LINES OVERVIEW

SUPPLY

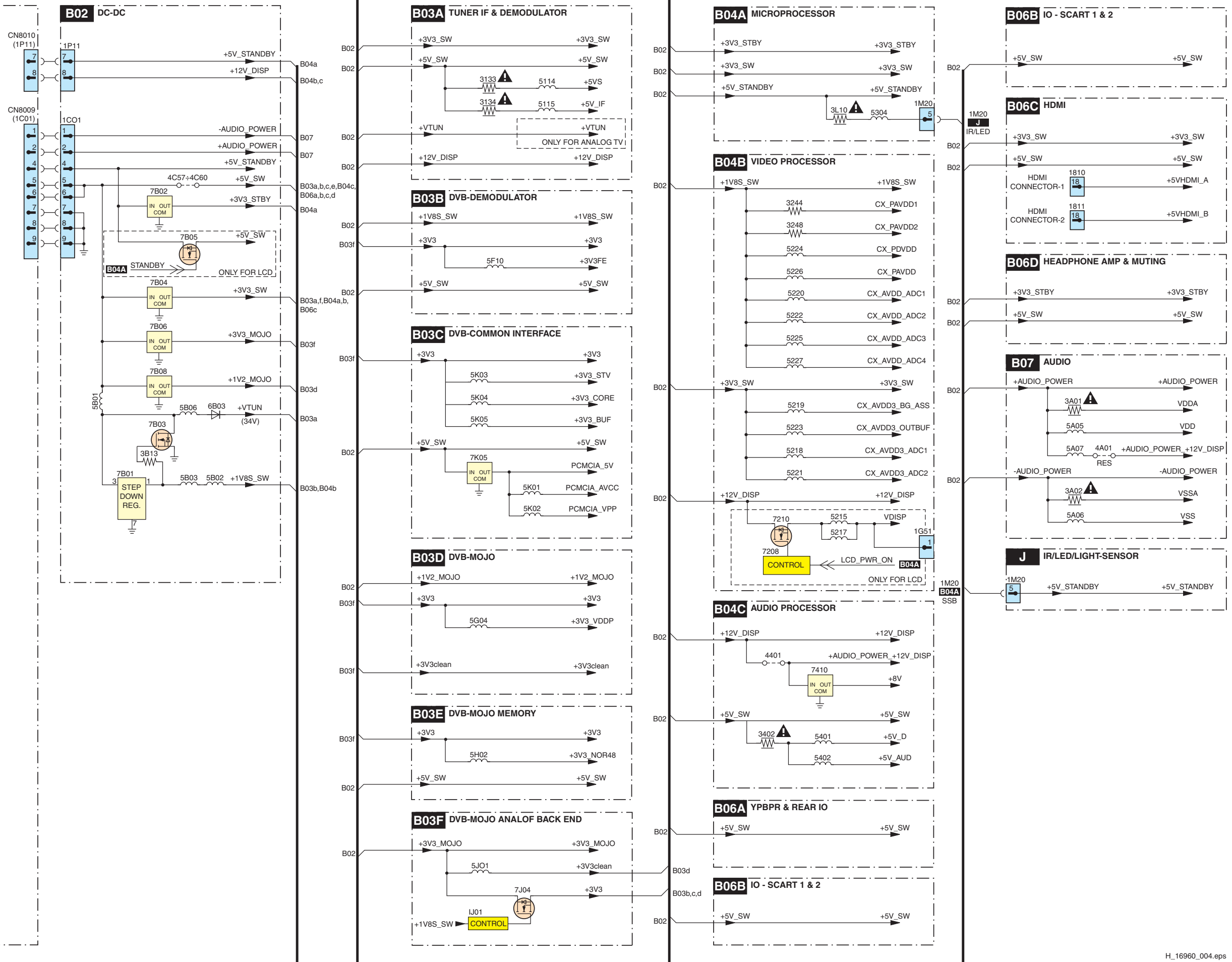

B02 DC - DC

B02

A

A

B

B

C

C

D

D

E

E

F

F

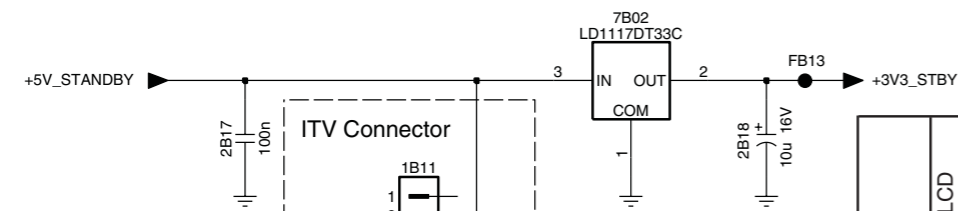
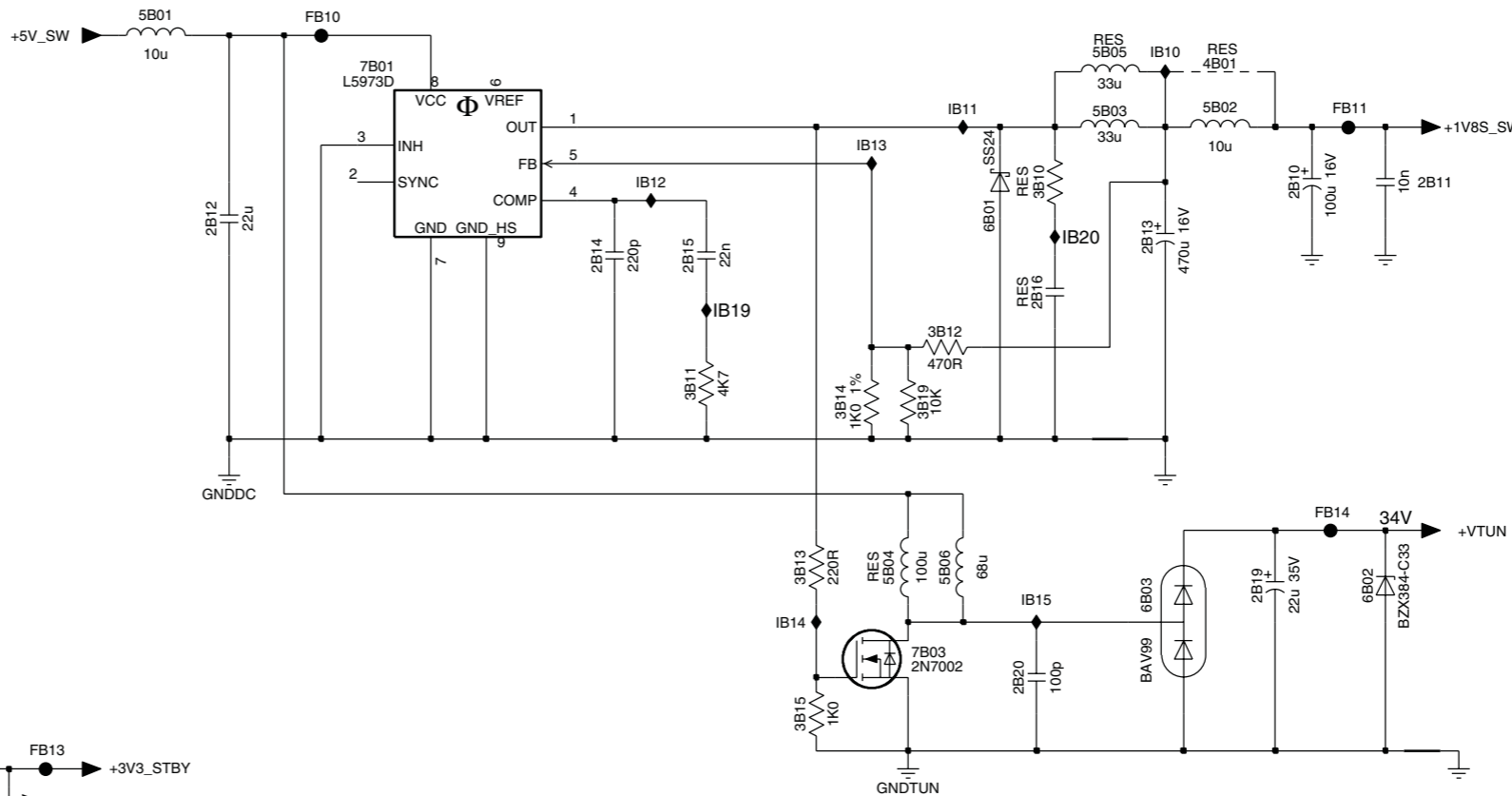
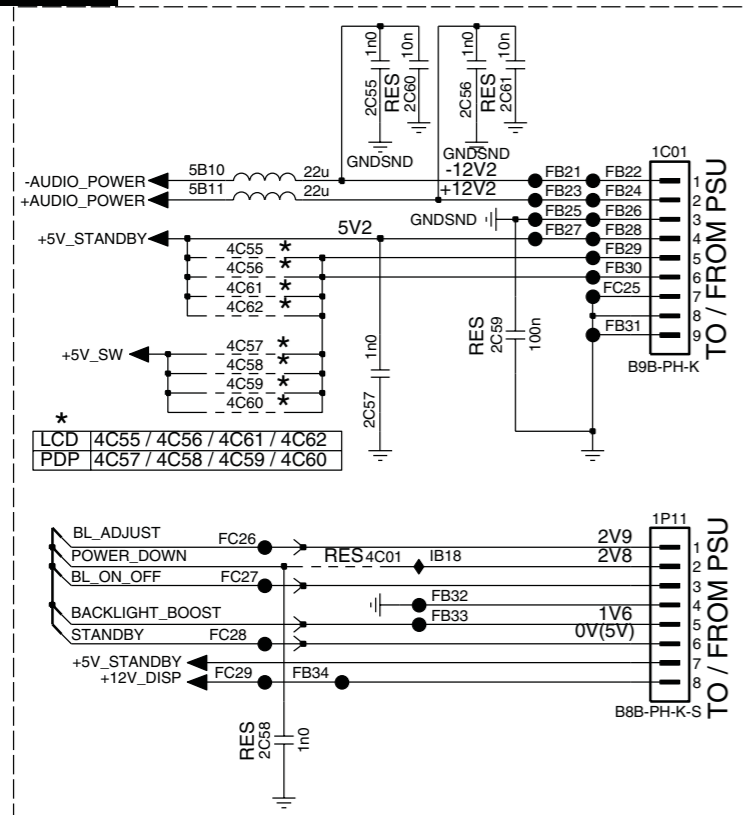

Item	EU-LCD	EU-PDP	EU ITV - LCD	Description
2B22	✓	✓	✓	ELCAP SM 35V 4U7 PM20 COL R
2B23	✓	✓	✓	ELCAP SM 16V 10U PM20 COL R
2B26	✓	✓	✓	ELCAP SM 16V 10U PM20 COL R
3B17	✓	✓	✓	RST SM 0603 6K8 PM5 COL
3B18	✓	✓	✓	RST SM 0603 6K8 PM5 COL
4C55	✓	✓	✓	RST SM 0603 JUMP. 0R05 COL
4C56	✓	✓	✓	RST SM 0603 JUMP. 0R05 COL
4C57	✓	✓	✓	RST SM 0603 JUMP. 0R05 COL
4C58	✓	✓	✓	RST SM 0603 JUMP. 0R05 COL
4C59	✓	✓	✓	RST SM 0603 JUMP. 0R05 COL
4C60	✓	✓	✓	RST SM 0603 JUMP. 0R05 COL
4C61	✓	✓	✓	RST SM 0603 JUMP. 0R05 COL
4C62	✓	✓	✓	RST SM 0603 JUMP. 0R05 COL
7B05	✓	✓	✓	IC SM LD1117DT33C (ST00) R
7B06	✓	✓	✓	IC SM LD1117DT (ST00) R
7B08	✓	✓	✓	IC SM LD1117DT (ST00) R

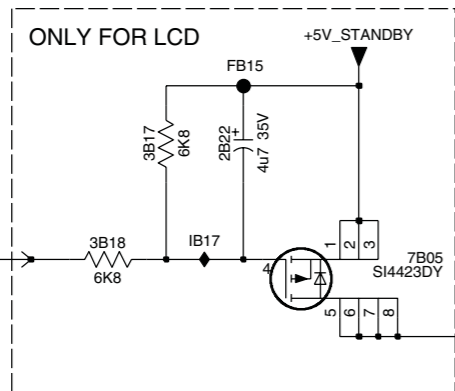
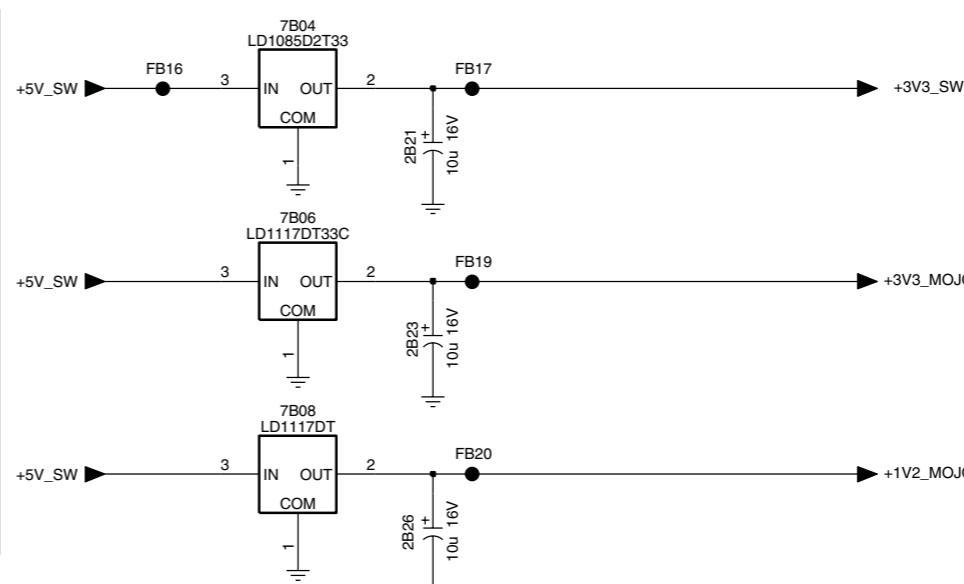

(---V) MEASURED IN STANDBY

3139 123 6261.1

- 1B11 D2
- 1C01 A3
- 1P11 C3
- 2B10 B8
- 2B11 B9
- 2B12 B4
- 2B13 B8
- 2B14 B6
- 2B15 B6
- 2B16 B7
- 2B17 D1
- 2B18 D3
- 2B19 C8
- 2B20 D7
- 2B21 E7
- 2B22 F2
- 2B23 E7
- 2B24 F3
- 2B25 F3
- 2B26 F7
- 2C55 A2
- 2C56 A2
- 2C57 B2
- 2C58 C2
- 2C59 B2
- 2C60 A2
- 2C61 A2
- 3B10 B7
- 3B11 C6
- 3B12 B7
- 3B13 C6
- 3B14 C7
- 3B15 D6
- 3B18 F2
- 3B19 C7
- 4B01 A8
- 4C01 C2
- 4C55 B1
- 4C56 B1
- 4C57 B1
- 4C58 B1
- 4C59 B1
- 4C60 B1
- 4C61 B1
- 4C62 B1
- 5B01 A4
- 5B02 A8
- 5B03 A8
- 5B04 C7
- 5B05 A8
- 5B06 C7
- 5B10 A1
- 5B11 A1
- 6B01 B7
- 6B02 C9
- 6B03 C8
- 7B01 A5
- 7B02 D3
- 7B03 D7
- 7B04 D6
- 7B05 F3
- 7B06 E6
- 7B08 F6
- FB10 A5
- FB11 A9
- FB13 D4
- FB14 C9
- FB15 E2
- FB16 D6
- FB17 D7
- FB19 E7
- FB20 F7
- FB21 A3
- FB22 A3
- FB23 A3
- FB24 A3
- FB25 A3
- FB26 A3
- FB27 A3
- FB28 A3
- FB29 B3
- FB30 B3
- FB31 B3
- FB32 C2
- FB33 C2
- FB34 C2
- FC25 B3
- FC26 C1
- FC27 C1
- FC28 C1
- FC29 C1
- IB10 A8
- IB11 A7
- IB12 B6
- IB13 B7
- IB14 C6
- IB15 C7
- IB17 F2
- IB18 C2
- IB19 B6
- IB20 B8

B03A TUNER IF & DEMODULATOR

B03A

A
B
C
D
E
F
G
H
I

A
B
C
D
E
F
G
H
I

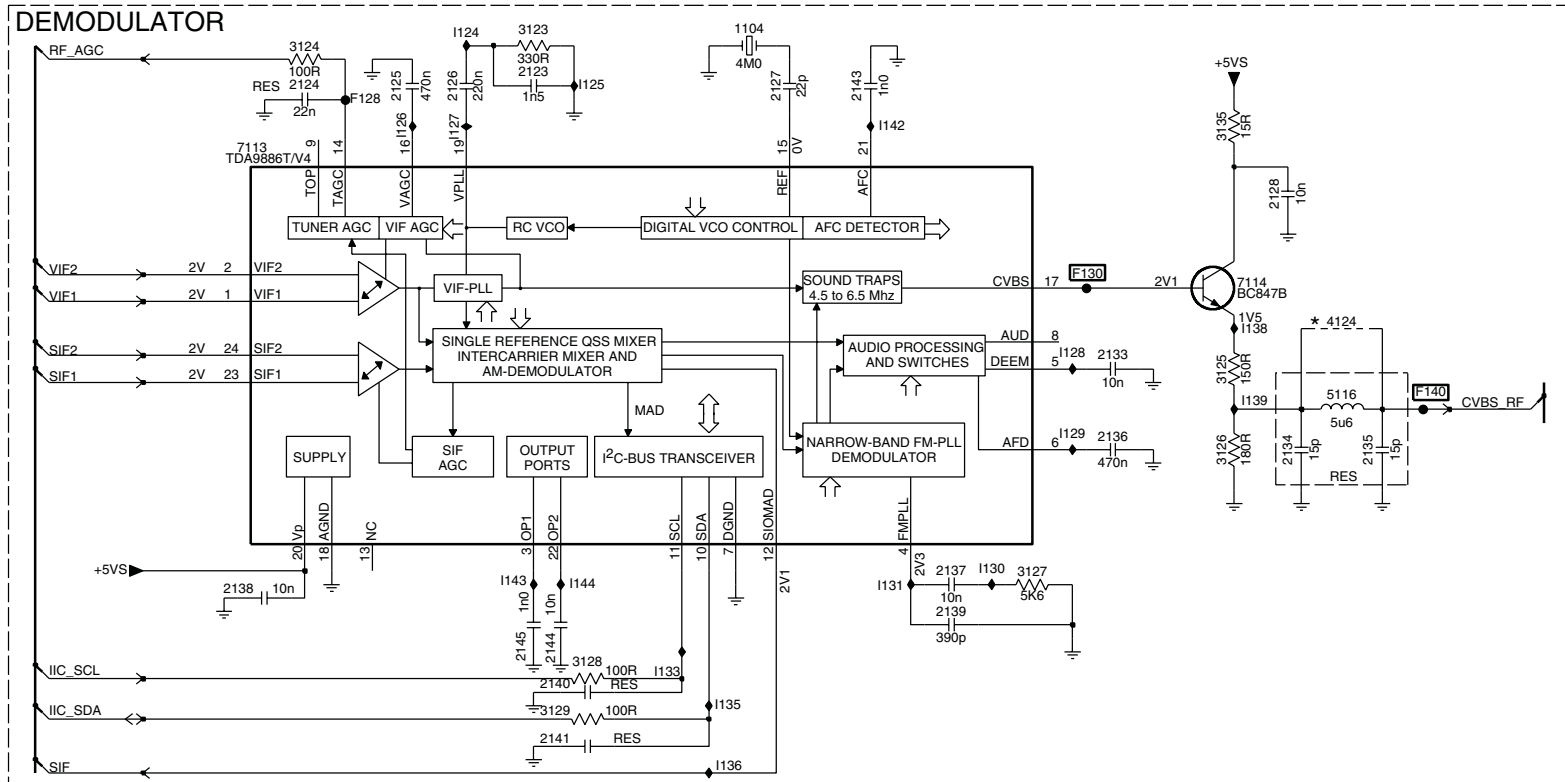
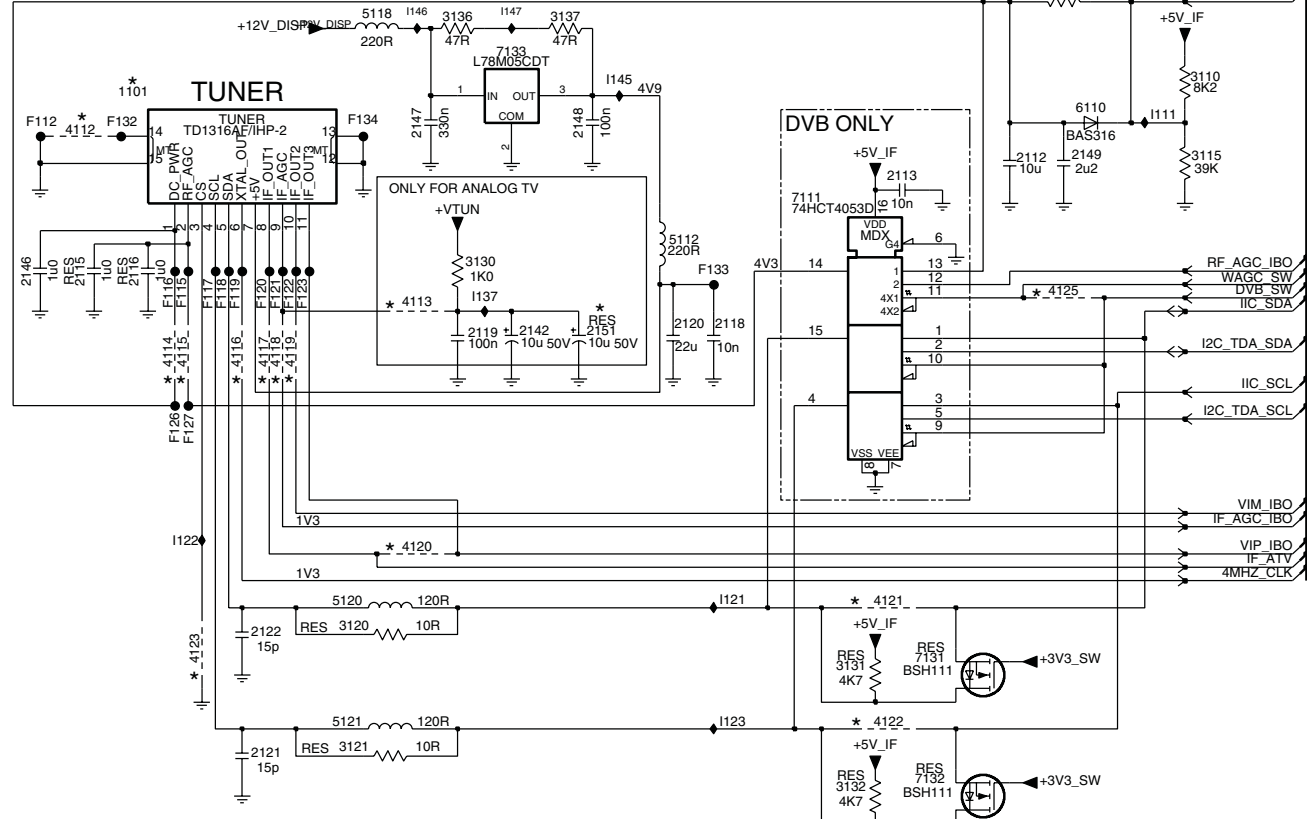
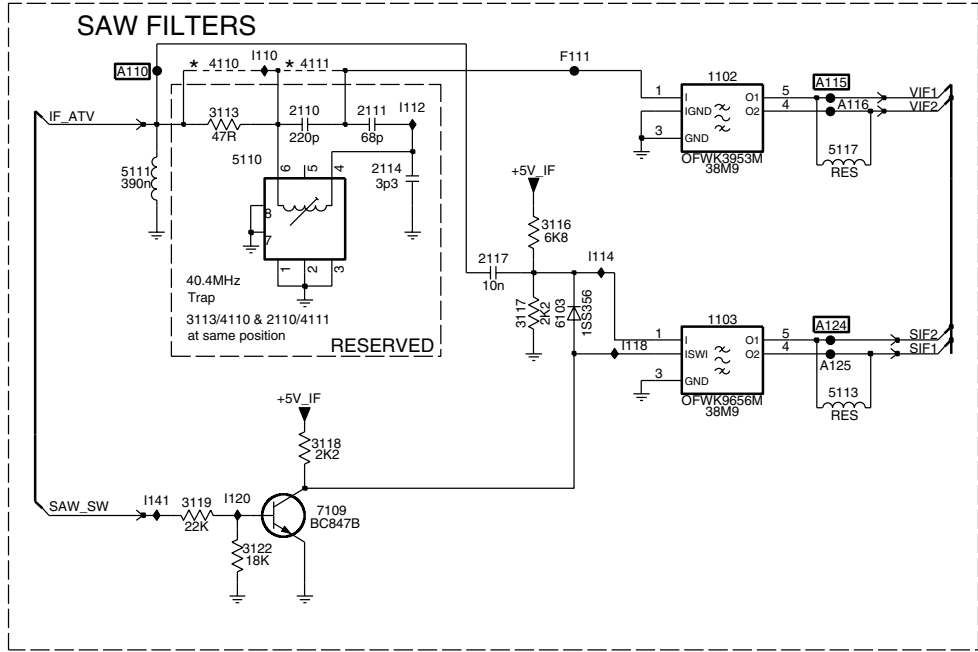

*	ANALOG	DIGITAL
4110	Y	Y
4111	Y	Y
4112	Y	Y
4113	Y	Y
4114	Y	Y
4115	Y	Y
4116	Y	Y
4117	Y	Y
4118	Y	Y
4119	Y	Y
4120	Y	Y
4121	Y	Y
4122	Y	Y
4123	Y	Y
4124	Y	Y

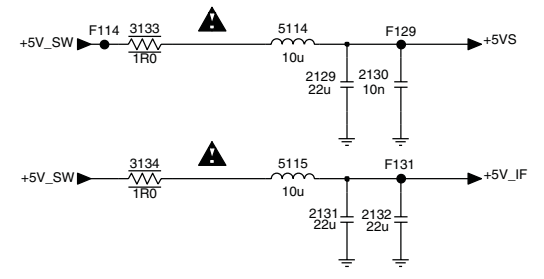

- A110 A6
- A111 B1
- A112 B5
- A113 C4
- A114 B5
- A115 C5
- A116 B5
- A117 B3
- A118 B6
- A119 B10
- A120 B6
- A121 B7
- A122 B7
- A123 B7
- A124 B7
- A125 B7
- A126 B7
- A127 B7
- A128 B7
- A129 B7
- A130 B7
- A131 B7
- A132 B7
- A133 B7
- A134 B7
- A135 B7
- A136 B7
- A137 B7
- A138 B7
- A139 B7
- A140 B7
- A141 B7
- A142 B7
- A143 B7
- A144 B7
- A145 B7
- A146 B7
- A147 B7
- A148 B7
- A149 B7
- A150 B7
- A151 B7
- A152 B7
- A153 B7
- A154 B7
- A155 B7
- A156 B7
- A157 B7
- A158 B7
- A159 B7
- A160 B7
- A161 B7
- A162 B7
- A163 B7
- A164 B7
- A165 B7
- A166 B7
- A167 B7
- A168 B7
- A169 B7
- A170 B7
- A171 B7
- A172 B7
- A173 B7
- A174 B7
- A175 B7
- A176 B7
- A177 B7
- A178 B7
- A179 B7
- A180 B7
- A181 B7
- A182 B7
- A183 B7
- A184 B7
- A185 B7
- A186 B7
- A187 B7
- A188 B7
- A189 B7
- A190 B7
- A191 B7
- A192 B7
- A193 B7
- A194 B7
- A195 B7
- A196 B7
- A197 B7
- A198 B7
- A199 B7
- A200 B7

B03B DVB - DEMODULATOR

B03B

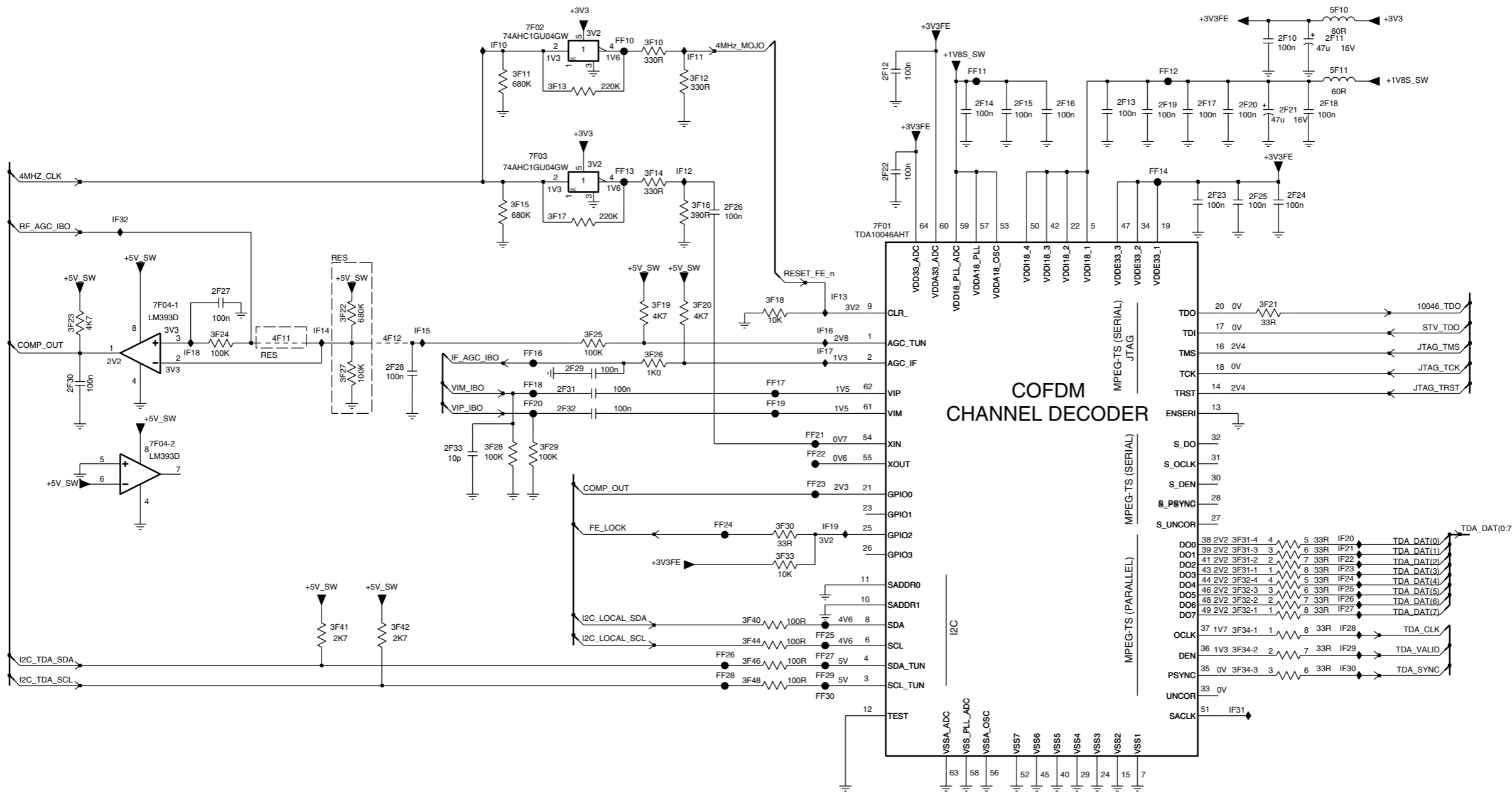

- 2F10 B10
- 2F11 B10
- 2F12 B7
- 2F13 B9
- 2F14 B8
- 2F15 B8
- 2F16 B8
- 2F17 B9
- 2F18 B10
- 2F19 B9
- 2F20 B9
- 2F22 C7
- 2F23 C9
- 2F24 C10
- 2F25 C10
- 2F26 C6
- 2F27 C2
- 2F28 D3
- 2F29 D5
- 2F30 D1
- 2F31 D5
- 2F32 D5
- 2F33 D4
- 3F10 B5
- 3F11 B4
- 3F12 B5
- 3F13 B5
- 3F14 C5
- 3F15 C4
- 3F16 C6
- 3F17 C5
- 3F18 C6
- 3F19 C5
- 3F20 C6
- 3F21 C10
- 3F22 D3
- 3F23 D1
- 3F24 D2
- 3F25 D5
- 3F26 D5
- 3F27 D3
- 3F28 D4
- 3F29 D5
- 3F30 E6
- 3F31-1 E9
- 3F31-2 E9
- 3F31-3 E9
- 3F31-4 E9
- 3F32-1 F9
- 3F32-2 F9
- 3F32-3 F9
- 3F32-4 E9
- 3F33 E6
- 3F34-1 F9
- 3F34-2 F9
- 3F34-3 F9
- 3F40 F6
- 3F41 F3
- 3F42 F3
- 3F44 F6
- 3F46 F6
- 3F48 F6
- 4F11 D3
- 4F12 D3
- 5F10 A10
- 5F11 B10
- 7F01 C7
- 7F02 B4
- 7F03 B4
- 7F04-1 C2
- 7F04-2 D2
- FF10 B5
- FF11 B8
- FF12 B9
- FF13 C5
- FF14 C9
- FF16 D4
- FF17 D6
- FF18 D4
- FF19 D6
- FF20 D4
- FF21 D6
- FF22 E6
- FF23 E6
- FF24 E6
- FF25 F6
- FF26 F6
- FF27 F6
- FF28 F6
- FF29 F6
- FF30 F6
- IF10 B4
- IF11 B6
- IF12 C5
- IF13 C7
- IF14 D3
- IF15 D4
- IF16 D6
- IF17 D6
- IF18 D2
- IF19 E6
- IF20 E10
- IF21 E10
- IF22 E10
- IF23 E10
- IF24 E10
- IF25 E10
- IF26 F10
- IF27 F10
- IF28 F10
- IF29 F10
- IF30 F10
- IF31 F9
- IF32 C1

B03C DVB-COMMON INTERFACE

B03C

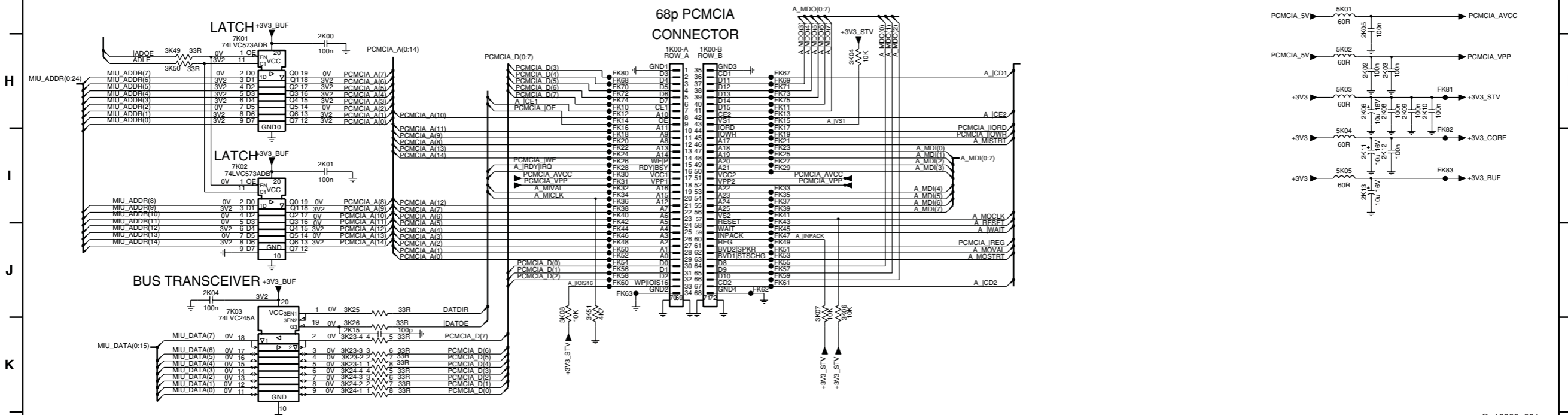
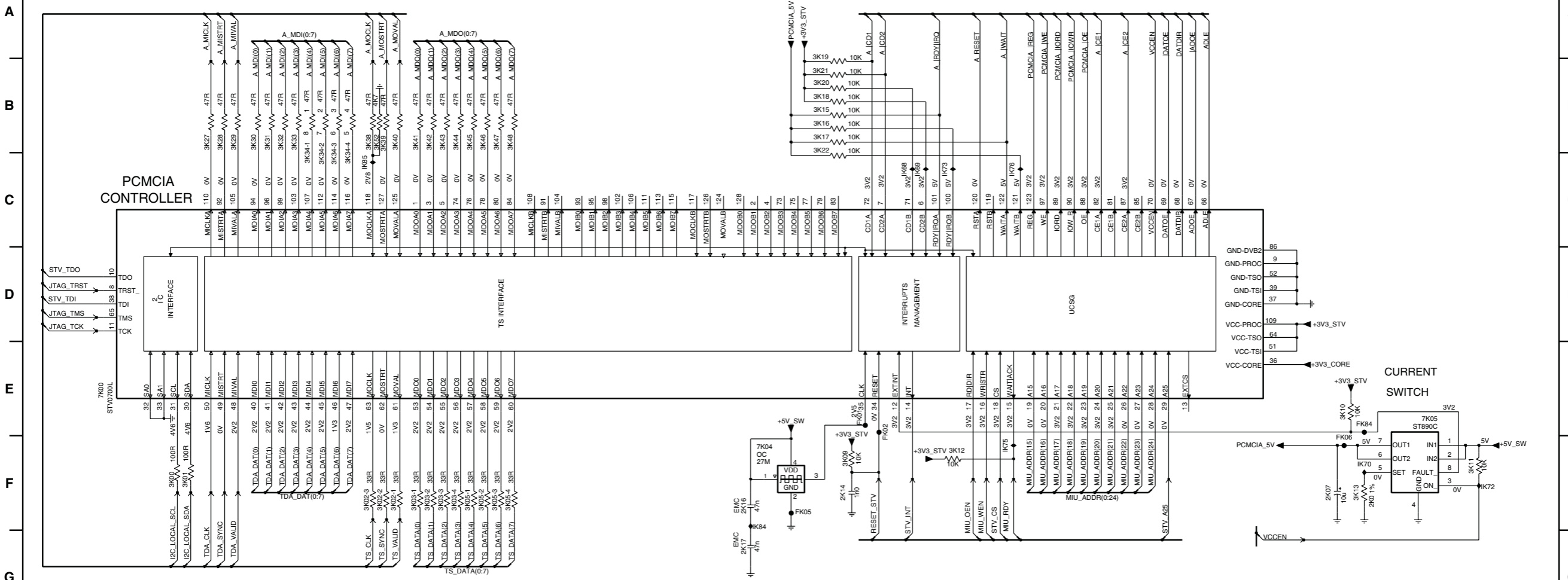

- 1K00-A H7
- 1K00-B H8
- 2K00 H4
- 2K01 I4
- 2K02 H15
- 2K03 H15
- 2K04 J2
- 2K05 G15
- 2K06 H15
- 2K07 F14
- 2K08 H15
- 2K09 H15
- 2K10 H15
- 2K11 H15
- 2K12 H15
- 2K13 H15
- 2K14 F9
- 2K15 K4
- 2K16 S 6
- 2K17 G8
- 3K00 F2
- 3K01 F2
- 3K02-1 F4
- 3K02-2 F4
- 3K03-1 F5
- 3K03-2 F5
- 3K03-3 F5
- 3K03-4 F5
- 3K04 H9
- 3K05-1 F5
- 3K05-2 F5
- 3K05-3 F5
- 3K05-4 F5
- 3K06 J9
- 3K07 J9
- 3K08 J6
- 3K09 F9
- 3K10 E14
- 3K11 F16
- 3K12 F10
- 3K13 F14
- 3K15 B9
- 3K16 B9
- 3K17 B9
- 3K18 B9
- 3K19 B9
- 3K20 B9
- 3K21 B9
- 3K22 B9
- 3K23-1 K4
- 3K23-2 K4
- 3K23-3 K4
- 3K23-4 K4
- 3K24-1 K4
- 3K24-2 K4
- 3K24-3 K4
- 3K24-4 K4
- 3K25 J4
- 3K26 K4
- 3K27 B2
- 3K28 B2
- 3K29 B3
- 3K30 B3
- 3K31 B3
- 3K32 B3
- 3K33 B3
- 3K34-1 B3
- 3K34-2 C3
- 3K34-3 C4
- 3K34-4 C4
- 3K38 B4
- 3K39 B4
- 3K40 B4
- 3K41 B5
- 3K42 B5
- 3K43 B5
- 3K44 B5
- 3K45 B5
- 3K46 B5
- 3K47 B5
- 3K48 B6
- 3K49 H2
- 3K50 H2
- 3K51 J6
- 3K52 B4
- 5K01 G14
- 5K02 H14
- 5K03 H14
- 5K05 H14
- 7K00 E1
- 7K01 H3
- 7K02 J3
- 7K03 J3
- 7K04 F8
- 7K05 E15
- FK01 E9
- FK02 E10
- FK05 F9
- FK06 F14
- FK10 H7
- FK11 H8
- FK12 H7
- FK13 H8
- FK14 H7
- FK15 H8
- FK16 H7
- FK17 H8
- FK18 I7
- FK19 B8
- FK20 I7
- FK21 I8
- FK22 I7
- FK23 I8
- FK24 I7
- FK25 I7
- FK26 I7
- FK27 I8
- FK28 I7
- FK29 I8
- FK30 I7
- FK31 I7
- FK32 I7
- FK33 I8
- FK34 I7
- FK35 I8
- FK36 I7
- FK37 I8
- FK38 I7
- FK39 I7
- FK40 I7
- FK41 I8
- FK42 I7
- FK43 I8
- FK44 J7
- FK45 J8
- FK46 J7
- FK47 J8
- FK48 J7
- FK49 J8
- FK50 J7
- FK51 J8
- FK52 J7
- FK53 J8
- FK54 J7
- FK55 J8
- FK56 J7
- FK57 J8
- FK58 J7
- FK59 J8
- FK60 J7
- FK61 J8
- FK62 J8
- FK63 I7
- FK64 J8
- FK65 J7
- FK66 H7
- FK67 H8
- FK68 H7
- FK69 H8
- FK70 H7
- FK71 H8
- FK72 H7
- FK73 H8
- FK74 H7
- FK75 H8
- FK76 H7
- FK77 H8
- FK78 H7
- FK79 H8
- FK80 H7
- FK81 H15
- FK82 H15
- FK83 H15
- FK84 F11
- FK85 C4
- FK86 C10
- FK87 F15
- FK88 C10
- FK89 F15
- FK90 C10
- FK91 F15
- FK92 F15
- FK93 F15
- FK94 F15
- FK95 F15
- FK96 F15
- FK97 F15
- FK98 F15
- FK99 F15
- FK100 F15

B03D DVB-MOJO

B03D

A
B
C
D
E
F
G
H
I

A
B
C
D
E
F
G
H
I

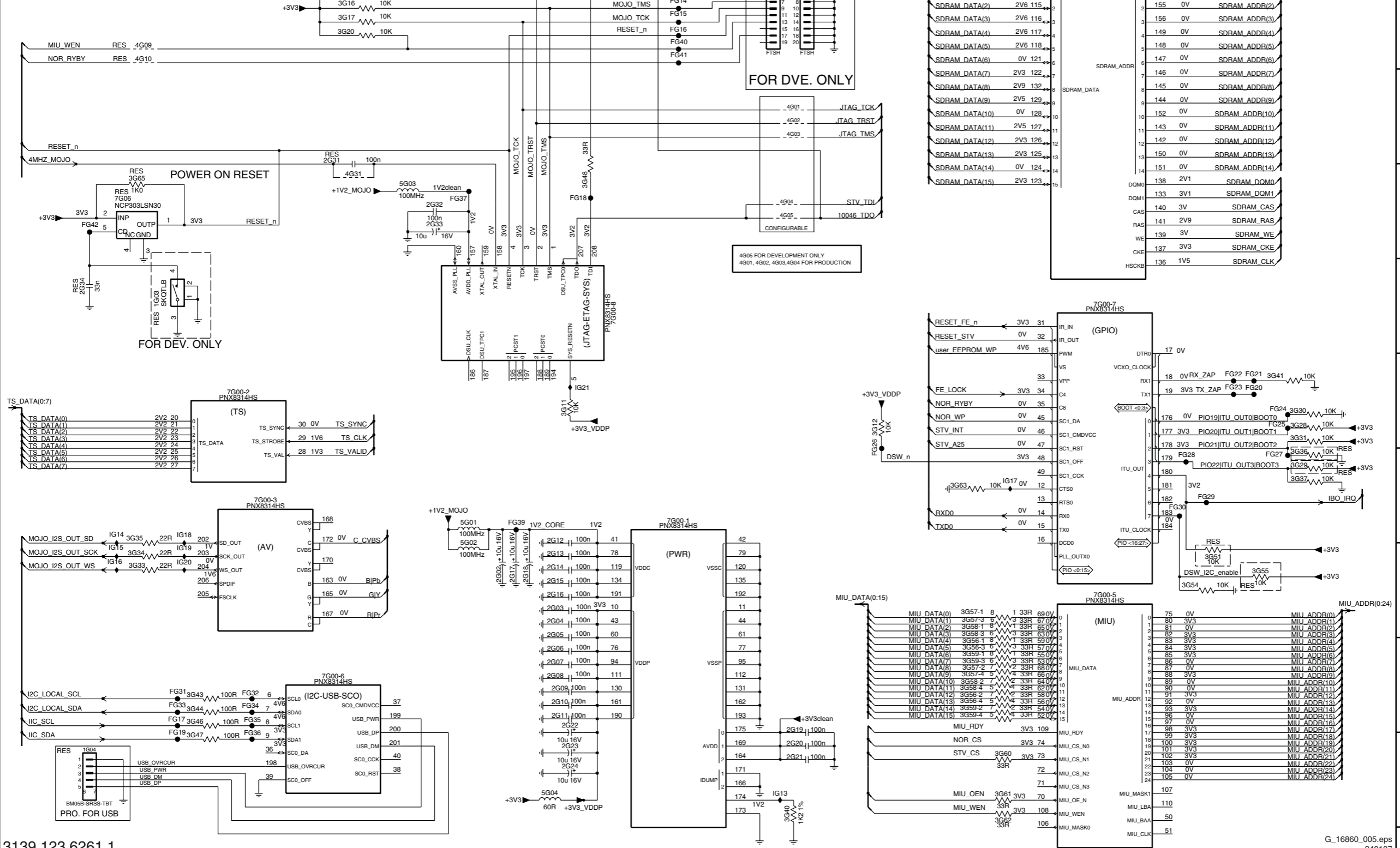

- 1G01-1 A8
- 1G01-2 A9
- 1G03 D2
- 1G04 I1
- 2G02 G5
- 2G03 G6
- 2G04 G6
- 2G05 G6
- 2G06 H6
- 2G07 H6
- 2G08 H6
- 2G09 H6
- 2G10 H6
- 2G11 H6
- 2G12 F6
- 2G13 G6
- 2G14 G6
- 2G15 G6
- 2G16 G6
- 2G17 G6
- 2G18 G6
- 2G19 H9
- 2G20 H9
- 2G21 I9
- 2G22 H6
- 2G23 I6
- 2G24 I6
- 2G31 B4
- 2G32 C5
- 2G33 C5
- 2G34 D1
- 3G11 E6
- 3G12 E9
- 3G15 A4
- 3G16 A4
- 3G17 A4
- 3G18 A4
- 3G19 A4
- 3G20 A4
- 3G28 E14
- 3G29 F14
- 3G30 E14
- 3G31 E14
- 3G32 G2
- 3G34 G2
- 3G35 F2
- 3G36 F14
- 3G37 F14
- 3G38 A4
- 3G40 I8
- 3G41 E14
- 3G43 H2
- 3G44 H2
- 3G46 H2
- 3G47 I2
- 3G48 C6
- 3G51 G13
- 3G54 G13
- 3G55 G13
- 3G56-1 H10
- 3G56-2 H10
- 3G56-3 H10
- 3G56-4 H10
- 3G57-1 G10
- 3G57-2 H10
- 3G57-3 G10
- 3G57-4 H10
- 3G58-1 G10
- 3G58-2 H10
- 3G58-3 G10
- 3G58-4 H10
- 3G59-1 H10
- 3G59-2 H10
- 3G59-3 H10
- 3G59-4 H10
- 3G60 I11
- 3G61 I11
- 3G62 I11
- 3G63 F10
- 3G65 C2
- 4G01 B9
- 4G02 B9
- 4G03 B9
- 4G04 C8
- 4G05 C8
- 4G09 A2
- 4G10 A2
- 4G31 C4
- 5G01 F5
- 5G02 G5
- 5G03 C4
- 5G04 I6
- 7G00-1 F7
- 7G00-2 E3
- 7G00-3 F3
- 7G00-4 A12
- 7G00-5 G12
- 7G00-6 H4
- 7G00-7 D12
- 7G00-8 D7
- 7G06 C1
- FG10 A7
- FG11 A7
- FG12 A7
- FG13 A9
- FG14 A7
- FG15 A7
- FG16 A7
- FG17 H2
- FG18 C6
- FG19 H2
- FG20 E13
- FG21 E13
- FG22 E13
- FG23 E13
- FG24 E14
- FG25 E13
- FG26 E9
- FG27 F14
- FG28 F13
- FG29 F13
- FG30 F13
- FG31 H2
- FG32 H3
- FG33 H2
- FG34 H3
- FG35 H3
- FG36 I3
- FG37 C5
- FG39 F6
- FG40 A7

B03E DVB-MOJO MEMORY

B03E

- 2H03 C2
- 2H04 A7
- 2H06 B1
- 2H07 A6
- 2H08 C2
- 2H09 C2
- 2H10 C2
- 2H11 C2
- 2H12 C2
- 2H13 C2
- 2H14 D6
- 2H15 D6
- 3H00 C4
- 3H05 C7
- 3H09 E7
- 3H10 E7
- 3H11 E7
- 3H12 E7
- 3H13 E7
- 3H14 D5
- 4H00 C5
- 4H01 C5
- 4H02 C5
- 4H03 C5
- 4H04 C5
- 4H05 C7
- 4H12 E7
- 4H15 C7
- 5H01 B1
- 5H02 A6
- 5H03 D5
- 7H00 A6
- 7H02 C1
- 7H03 D5
- FH00 E7
- FH01 D5
- FH02 E7
- FH03 D6
- FH04 E7
- FH05 D5
- FH06 D5
- FH07 B2
- FH08 A6
- IH04 C5
- IH06 C7
- IH07 C7

A

A

B

B

C

C

D

D

E

E

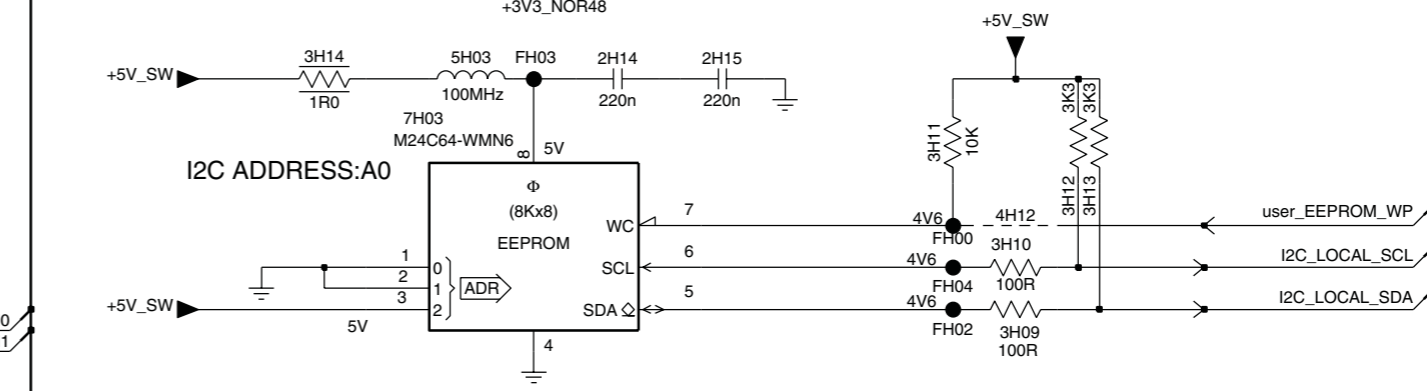
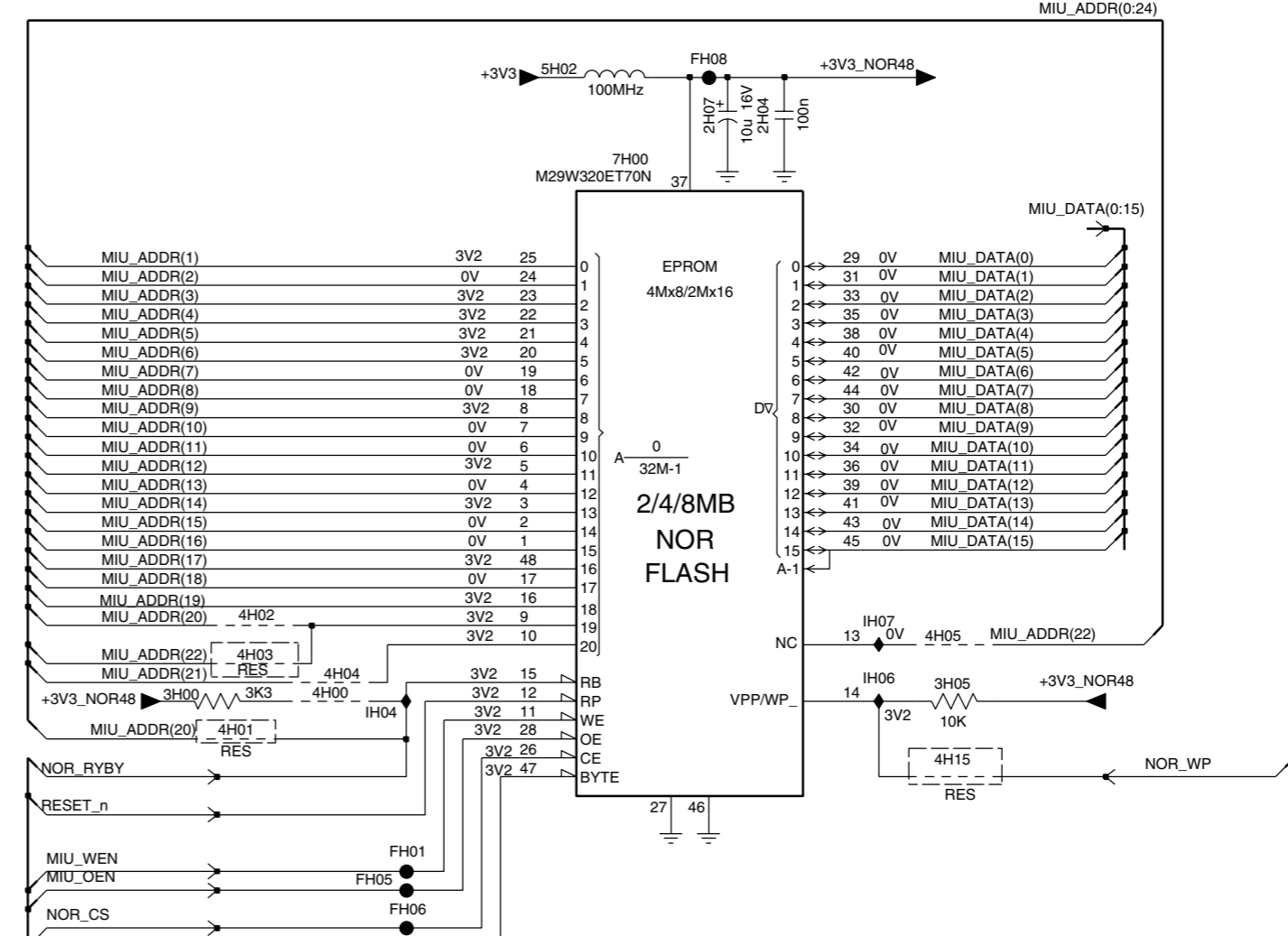
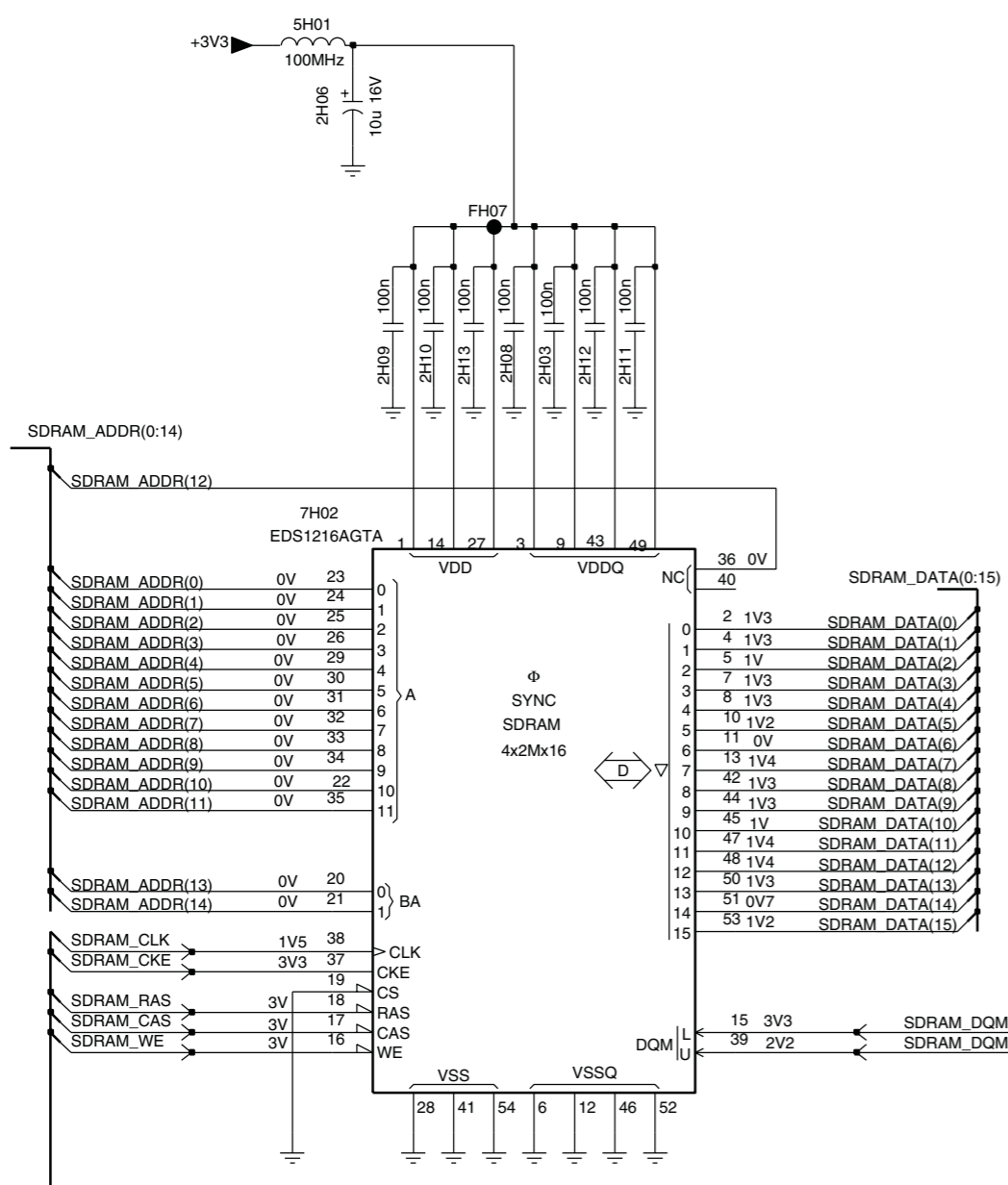

B03F DVB-MOJO ANALOG BACK END

B03F

- IJ66 C1
- IJ67 D8
- IJ68 D8
- 1001 D7
- 1002 D7
- 1J14 D6
- 2J01 B7
- 2J02 B7
- 2J04 B8
- 2J05 C8
- 2J06 C9
- 2J14 D8
- 2J15 D8
- 2J60 A2
- 2J62 B3
- 2J63 B2
- 2J64 C2
- 2J66 C2
- 2J67 C3
- 2J68 D2
- 2J69 D2
- 2J70 D3
- 2J71 E2
- 2J72 E2
- 2J73 E2
- 3J01 B8
- 3J02 B8
- 3J03 B6
- 3J14 D8
- 3J15 D8
- 3J59 B2
- 3J60 B3
- 3J61 C2
- 3J62 C3
- 3J63 D2
- 3J64 D3
- 3J65 E2
- 3J66 E3
- 4J14 D8
- 4J15 D8
- 5J01 A6
- 5J52 A2
- 5J53 C2
- 5J54 D2
- 5J55 E2
- 6J03 C7
- 6J14 D7
- 6J15 D8
- 6J60 B3
- 6J61 C3
- 6J62 D3
- 6J63 E3
- 7J04 B9
- 7J05 B7
- FJ01 B9
- FJ02 D6
- FJ22 A4
- FJ23 C4
- FJ24 D8
- FJ25 D8
- FJ26 D4
- FJ27 E4
- IJ01 B7
- IJ02 B8
- IJ11 A8
- IJ63 B1
- IJ64 C1
- IJ65 C1

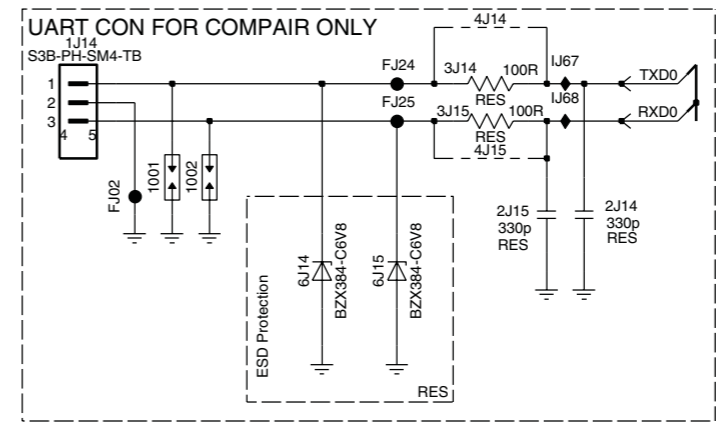
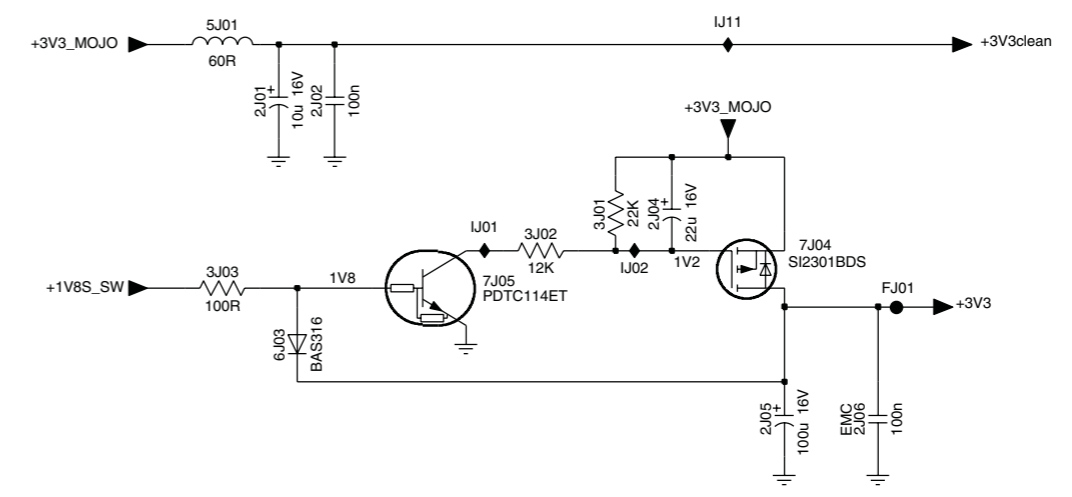
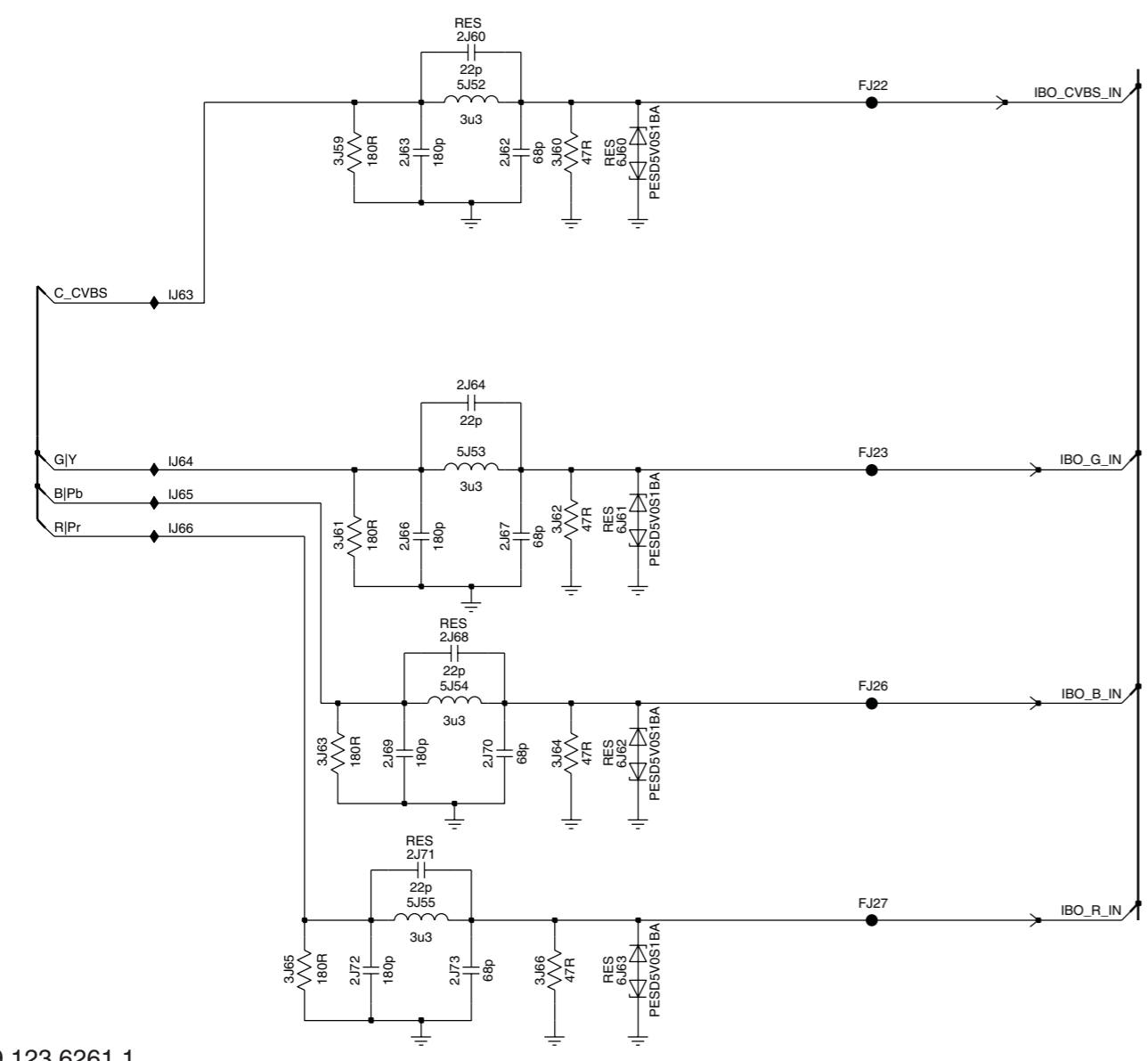

B04A MICROPROCESSOR

B04A

Item	TV	with Side AV	Other region	Description
1304	TV			CON V 11P M 2.00 PH B
1312	TV			CON V 10P M 2.00 SM PH R
1320	TV			CON V 8P M 2.00 PH B
1M20	TV			CON V 7P M 2.00 PH B
2321	TV			CER1 0603 NPO 50V 22P COL
3320	TV			RST SM 0603 100R PMS COL
3322	TV			RST SM 0603 100R PMS COL
3351	TV			RST SM 0603 3K3 PMS COL
3352	TV			RST SM 0603 3K3 PMS COL
3353	TV			RST SM 0603 100R PMS COL
3354	TV			RST SM 0603 100R PMS COL
3356	TV			RST SM 0603 100R PMS COL
3370	TV			RST SM 0603 100R PMS COL
3L08	TV			RST SM 0603 100R PMS COL
3L10	TV			RST SM 0603 100R PMS COL
3L12	TV			RST SM 0603 10K PMS COL
3L13	TV			RST SM 0603 10K PMS COL
4L09	TV			RST SM 0603 JUMP_0R05 COL

A
B
C
D
E
F
G
H
I

A
B
C
D
E
F
G
H
I

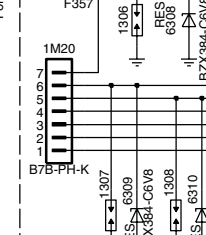
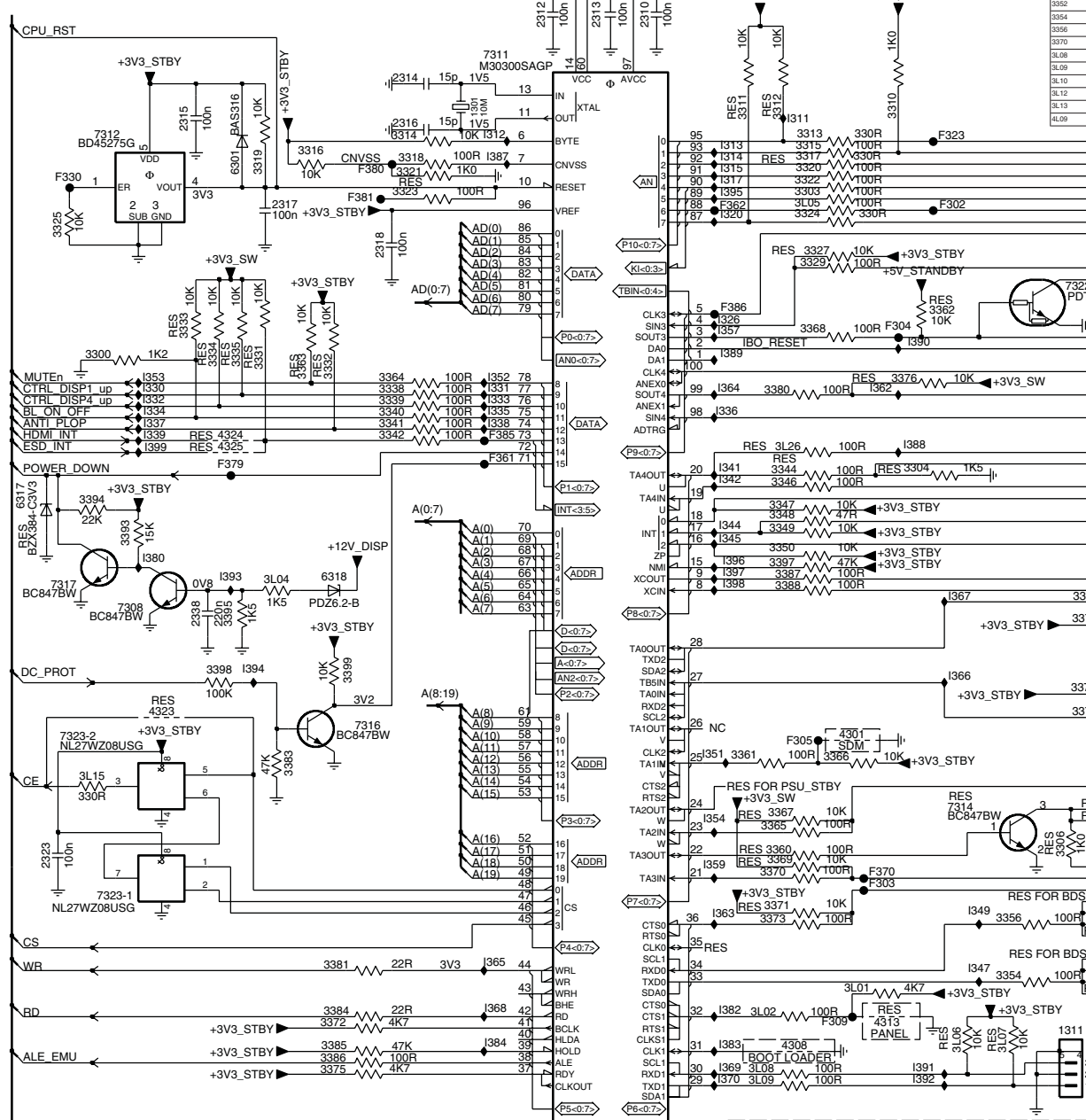

TO / FROM SIDE IO

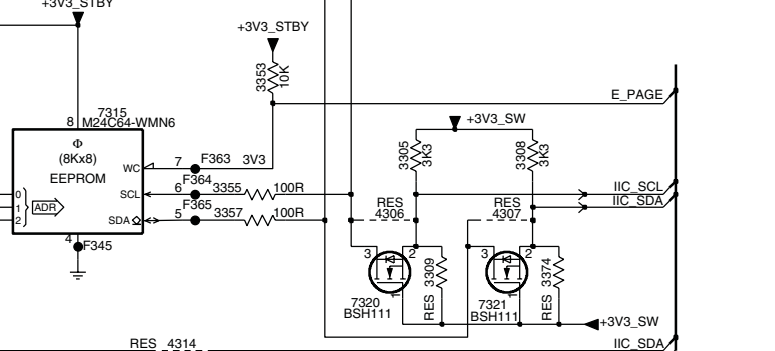
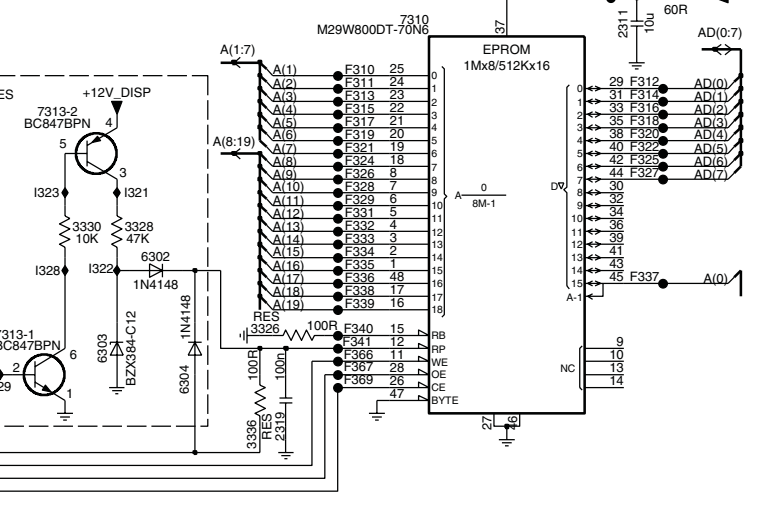
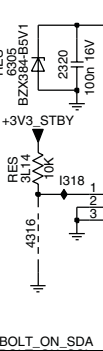
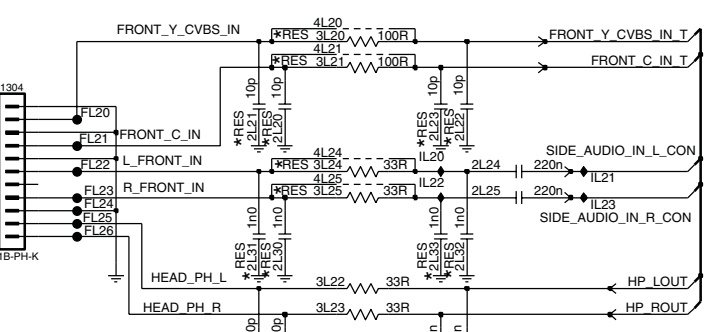

TO / FROM IR/ LED & KEYBOARD

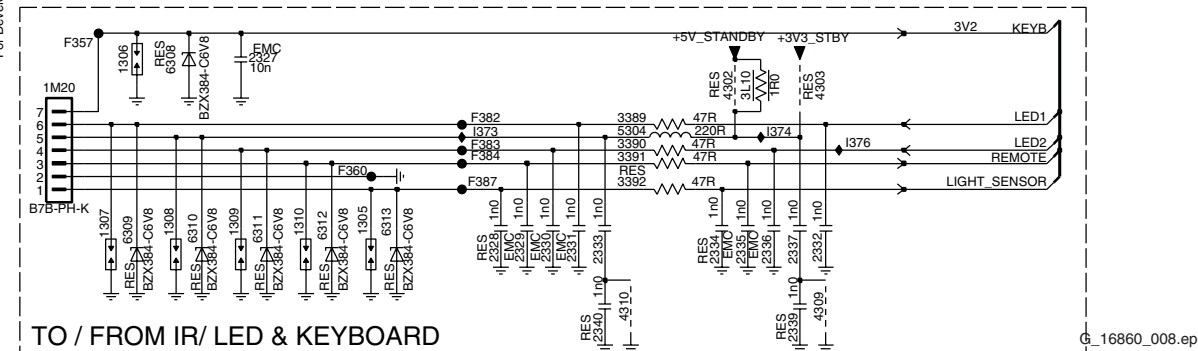

- 1301 B3 3376 D6 F341 E11
- 1302 I2 3377 E7 F342 I2
- 1303 I2 3378 I2 F343 I2
- 1304 A9 3379 E7 F344 I3
- 1305 I9 3380 D5 F345 G10
- 1306 H8 3381 G2 F346 H5
- 1307 I8 3382 E7 F347 I5
- 1308 I8 3383 F2 F348 I5
- 1309 I8 3384 H2 F349 I5
- 1310 I9 3385 H2 F350 F8
- 1311 H7 3386 H2 F351 I5
- 1312 H5 3387 E5 F352 I5
- 1314 I3 3388 E5 F353 I5
- 1M20 H8 3389 I1 F354 I5
- 2310 A4 3390 I1 F355 E8
- 2311 C13 3391 H1 F357 H8
- 2312 A4 3392 I1 F360 I9
- 2313 A4 3393 E1 F361 D3
- 2314 B3 3394 D1 F362 C5
- 2315 B1 3395 E2 F363 G11
- 2316 B3 3396 C7 F364 G11
- 2317 B2 3397 E5 F365 G11
- 2318 C3 3398 E2 F366 I1
- 2319 E11 3399 E2 F367 E1
- 2320 F9 3L01 G6 F368 C13
- 2321 G7 3L02 H5 F369 E11
- 2322 G7 3L04 E2 F370 G6
- 2323 G1 3L05 B5 F379 D2
- 2324 F7 3L06 H6 F380 B3
- 2325 F8 3L07 H7 F381 B3
- 2326 E8 3L08 H5 F382 I10
- 2327 H9 3L09 H5 F383 I10
- 2328 I10 3L10 H11 F384 I10
- 2329 I10 3L11 G7 F385 D3
- 2330 I10 3L12 G7 F386 C5
- 2331 I10 3L13 G7 F387 I10
- 2332 I12 3L14 G9 F388 I10
- 2333 I10 3L15 F1 FL21 A9
- 2334 I11 3L20 A11 FL22 A9
- 2335 I11 3L21 A11 FL23 A9
- 2336 I11 3L22 B11 FL24 A9
- 2337 I12 3L23 B11 FL25 A9
- 2338 E2 3L24 A11 FL26 A9
- 2339 I12 3L25 A11 I311 B5
- 2340 I10 3L26 D5 I312 B3
- 2341 I10 4301 F6 I313 B5
- 2342 A10 4302 H11 I314 B5
- 2343 A11 4303 H12 I315 B5
- 2344 A11 4304 G12 I316 G9
- 2345 A12 4305 H5 I320 C5
- 2346 A12 4306 H5 I321 D10
- 2347 B10 4307 H11 I322 D10
- 2348 B11 4308 H5 I323 D10
- 2349 B11 4309 H11 I326 C5
- 2350 B10 4310 H11 I328 D10
- 2351 B11 4311 G9 I329 E9
- 2352 B11 4312 F1 I330 D1
- 2353 B11 4324 D2 I331 D3
- 2354 C1 4325 D2 I332 D1
- 2355 B5 4326 A11 I333 D3
- 2356 G6 4327 A11 I334 D1
- 2357 D12 4328 A11 I335 D3
- 2358 F7 4329 A11 I336 D5
- 2359 G12 5301 A4 I337 D1
- 2360 G12 5302 C13 I338 D1
- 2361 B2 6301 B2 I341 D5
- 2362 B5 6302 D10 I342 D5
- 2363 B5 6303 E10 I344 D5
- 2364 B3 6305 F9 I347 G6
- 2365 B5 6306 I2 I349 G6
- 2366 B2 6307 I2 I351 F5
- 2367 B5 6308 H8 I352 D3
- 2368 B3 6309 I8 I353 D1
- 2369 B2 6310 I8 I354 F5
- 2370 B5 6311 I9 I357 C5
- 2371 B5 6312 I8 I359 G5
- 2372 B5 6313 I9 I362 D6
- 2373 B3 6317 D1 I363 G5
- 2374 C5 6318 E2 I364 D5
- 2375 C1 7308 E1 I365 G3
- 2376 D11 7310 C12 I366 E6
- 2377 C5 7311 B3 I367 E6
- 2378 D10 7312 B1 I368 G3
- 2379 C5 7313-1 D9 I369 H5
- 2380 D10 7313-2 C10 I370 H5
- 2381 C2 7314 F6 I373 I10
- 2382 D2 7315 F10 I374 H1
- 2383 C1 7316 F2 I376 H2
- 2384 C2 7317 E1 I380 E1
- 2385 C2 7320 H1 I382 G5
- 2386 E11 7321 H2 I383 H5
- 2387 E9 7322 C7 I384 H3
- 2388 D3 7323-1 G1 I387 B3
- 2389 D3 7323-2 F1 I388 D6
- 2390 D3 7324 C6 I389 C5
- 2391 D3 7325 B5 I390 C6
- 2392 D3 7326 C6 I391 H6
- 2393 I1 7327 F5 I392 H6
- 2394 D5 7328 F5 I393 E2
- 2395 I1 7329 C11 I394 E2
- 2396 D5 7330 C11 I395 B5
- 2397 D5 7331 C3 I396 E5
- 2398 D5 7332 H1 I397 E5
- 2399 E5 7334 C13 I398 E5
- 2400 E5 7335 C11 I399 D1
- 2401 G7 7336 C13 I420 A11
- 2402 G7 7337 C13 I421 A11
- 2403 G7 7338 C13 I422 A11
- 2404 G7 7339 C13 I423 A11
- 2405 G7 7340 C13 I424 A11
- 2406 G7 7341 C13 I425 A11
- 2407 G7 7342 C13 I426 A11
- 2408 G7 7343 C13 I427 A11
- 2409 G7 7344 C13 I428 A11
- 2410 G7 7345 C13 I429 A11
- 2411 G7 7346 C13 I430 A11
- 2412 G7 7347 C13 I431 A11
- 2413 G7 7348 C13 I432 A11
- 2414 G7 7349 C13 I433 A11
- 2415 G7 7350 C13 I434 A11
- 2416 G7 7351 C13 I435 A11
- 2417 G7 7352 C13 I436 A11
- 2418 G7 7353 C13 I437 A11
- 2419 G7 7354 C13 I438 A11
- 2420 G7 7355 C13 I439 A11
- 2421 G7 7356 C13 I440 A11
- 2422 G7 7357 C13 I441 A11
- 2423 G7 7358 C13 I442 A11
- 2424 G7 7359 C13 I443 A11
- 2425 G7 7360 C13 I444 A11
- 2426 G7 7361 C13 I445 A11
- 2427 G7 7362 C13 I446 A11
- 2428 G7 7363 C13 I447 A11
- 2429 G7 7364 C13 I448 A11
- 2430 G7 7365 C13 I449 A11
- 2431 G7 7366 C13 I450 A11
- 2432 G7 7367 C13 I451 A11
- 2433 G7 7368 C13 I452 A11
- 2434 G7 7369 C13 I453 A11
- 2435 G7 7370 C13 I454 A11
- 2436 G7 7371 C13 I455 A11
- 2437 G7 7372 C13 I456 A11
- 2438 G7 7373 C13 I457 A11
- 2439 G7 7374 C13 I458 A11
- 2440 G7 7375 C13 I459 A11
- 2441 G7 7376 C13 I460 A11
- 2442 G7 7377 C13 I461 A11
- 2443 G7 7378 C13 I462 A11
- 2444 G7 7379 C13 I463 A11
- 2445 G7 7380 C13 I464 A11
- 2446 G7 7381 C13 I465 A11
- 2447 G7 7382 C13 I466 A11
- 2448 G7 7383 C13 I467 A11
- 2449 G7 7384 C13 I468 A11
- 2450 G7 7385 C13 I469 A11
- 2451 G7 7386 C13 I470 A11
- 2452 G7 7387 C13 I471 A11
- 2453 G7 7388 C13 I472 A11
- 2454 G7 7389 C13 I473 A11
- 2455 G7 7390 C13 I474 A11
- 2456 G7 7391 C13 I475 A11
- 2457 G7 7392 C13 I476 A11
- 2458 G7 7393 C13 I477 A11
- 2459 G7 7394 C13 I478 A11
- 2460 G7 7395 C13 I479 A11
- 2461 G7 7396 C13 I480 A11
- 2462 G7 7397 C13 I481 A11
- 2463 G7 7398 C13 I482 A11
- 2464 G7 7399 C13 I483 A11
- 2465 G7 7400 C13 I484 A11

B04B VIDEO PROCESSOR

B04B

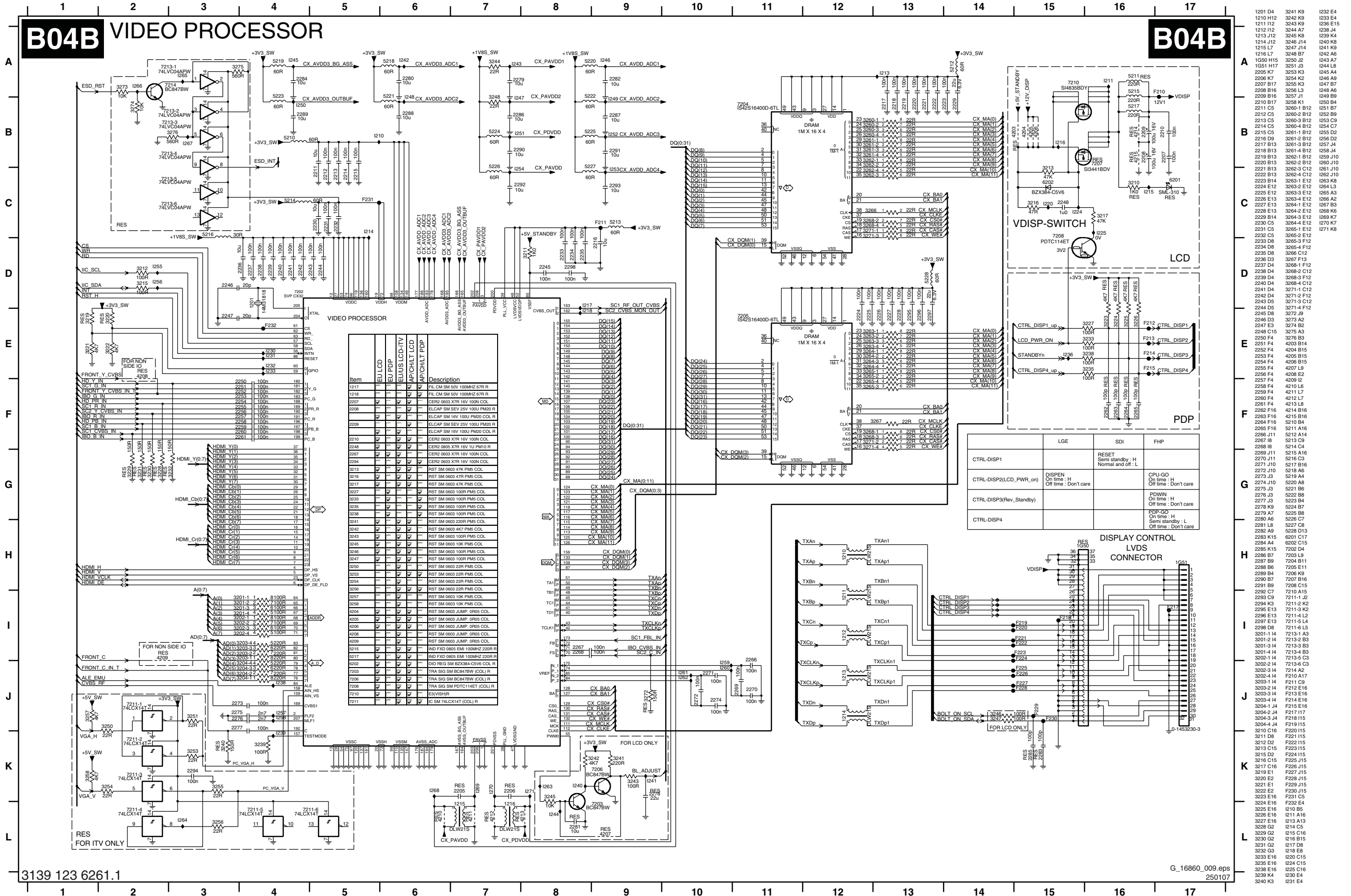

Item	EU LCD	EU PDP	EU/S LCD-TV	AP/CH/ALT PDP	Description
1217					FL CM SM 50V 100MHZ 27R R
1218					FL CM SM 50V 100MHZ 67R R
1219					CER2 9603 X7R 16V 100N COL
1220					ELCAP SM 5EV 25V 100U PM20 R
1221					ELCAP SM 16V 100U PM20 COL R
1222					ELCAP SM 5EV 25V 100U PM20 R
1223					ELCAP SM 16V 100U PM20 COL R
1224					CER2 9603 X7R 16V 100N COL
1225					CER2 9603 X7R 16V 100N COL
1226					RST SM 0603 47R PM5 COL
1227					RST SM 0603 47R PM5 COL
1228					RST SM 0603 47R PM5 COL
1229					RST SM 0603 47R PM5 COL
1230					RST SM 0603 47R PM5 COL
1231					RST SM 0603 47R PM5 COL
1232					RST SM 0603 47R PM5 COL
1233					RST SM 0603 47R PM5 COL
1234					RST SM 0603 47R PM5 COL
1235					RST SM 0603 47R PM5 COL
1236					RST SM 0603 47R PM5 COL
1237					RST SM 0603 47R PM5 COL
1238					RST SM 0603 47R PM5 COL
1239					RST SM 0603 47R PM5 COL
1240					RST SM 0603 47R PM5 COL
1241					RST SM 0603 47R PM5 COL
1242					RST SM 0603 47R PM5 COL
1243					RST SM 0603 47R PM5 COL
1244					RST SM 0603 47R PM5 COL
1245					RST SM 0603 47R PM5 COL
1246					RST SM 0603 47R PM5 COL
1247					RST SM 0603 47R PM5 COL
1248					RST SM 0603 47R PM5 COL
1249					RST SM 0603 47R PM5 COL
1250					RST SM 0603 47R PM5 COL
1251					RST SM 0603 47R PM5 COL
1252					RST SM 0603 47R PM5 COL
1253					RST SM 0603 47R PM5 COL
1254					RST SM 0603 47R PM5 COL
1255					RST SM 0603 47R PM5 COL
1256					RST SM 0603 47R PM5 COL
1257					RST SM 0603 47R PM5 COL
1258					RST SM 0603 47R PM5 COL
1259					RST SM 0603 47R PM5 COL
1260					RST SM 0603 47R PM5 COL
1261					RST SM 0603 47R PM5 COL
1262					RST SM 0603 47R PM5 COL
1263					RST SM 0603 47R PM5 COL
1264					RST SM 0603 47R PM5 COL
1265					RST SM 0603 47R PM5 COL
1266					RST SM 0603 47R PM5 COL
1267					RST SM 0603 47R PM5 COL
1268					RST SM 0603 47R PM5 COL
1269					RST SM 0603 47R PM5 COL
1270					RST SM 0603 47R PM5 COL
1271					RST SM 0603 47R PM5 COL
1272					RST SM 0603 47R PM5 COL
1273					RST SM 0603 47R PM5 COL
1274					RST SM 0603 47R PM5 COL
1275					RST SM 0603 47R PM5 COL
1276					RST SM 0603 47R PM5 COL
1277					RST SM 0603 47R PM5 COL
1278					RST SM 0603 47R PM5 COL
1279					RST SM 0603 47R PM5 COL
1280					RST SM 0603 47R PM5 COL
1281					RST SM 0603 47R PM5 COL
1282					RST SM 0603 47R PM5 COL
1283					RST SM 0603 47R PM5 COL
1284					RST SM 0603 47R PM5 COL
1285					RST SM 0603 47R PM5 COL
1286					RST SM 0603 47R PM5 COL
1287					RST SM 0603 47R PM5 COL
1288					RST SM 0603 47R PM5 COL
1289					RST SM 0603 47R PM5 COL
1290					RST SM 0603 47R PM5 COL
1291					RST SM 0603 47R PM5 COL
1292					RST SM 0603 47R PM5 COL
1293					RST SM 0603 47R PM5 COL
1294					RST SM 0603 47R PM5 COL
1295					RST SM 0603 47R PM5 COL
1296					RST SM 0603 47R PM5 COL
1297					RST SM 0603 47R PM5 COL
1298					RST SM 0603 47R PM5 COL
1299					RST SM 0603 47R PM5 COL
1300					RST SM 0603 47R PM5 COL
1301					RST SM 0603 47R PM5 COL
1302					RST SM 0603 47R PM5 COL
1303					RST SM 0603 47R PM5 COL
1304					RST SM 0603 47R PM5 COL
1305					RST SM 0603 47R PM5 COL
1306					RST SM 0603 47R PM5 COL
1307					RST SM 0603 47R PM5 COL
1308					RST SM 0603 47R PM5 COL
1309					RST SM 0603 47R PM5 COL
1310					RST SM 0603 47R PM5 COL
1311					RST SM 0603 47R PM5 COL
1312					RST SM 0603 47R PM5 COL
1313					RST SM 0603 47R PM5 COL
1314					RST SM 0603 47R PM5 COL
1315					RST SM 0603 47R PM5 COL
1316					RST SM 0603 47R PM5 COL
1317					RST SM 0603 47R PM5 COL
1318					RST SM 0603 47R PM5 COL
1319					RST SM 0603 47R PM5 COL
1320					RST SM 0603 47R PM5 COL
1321					RST SM 0603 47R PM5 COL
1322					RST SM 0603 47R PM5 COL
1323					RST SM 0603 47R PM5 COL
1324					RST SM 0603 47R PM5 COL
1325					RST SM 0603 47R PM5 COL
1326					RST SM 0603 47R PM5 COL
1327					RST SM 0603 47R PM5 COL
1328					RST SM 0603 47R PM5 COL
1329					RST SM 0603 47R PM5 COL
1330					RST SM 0603 47R PM5 COL
1331					RST SM 0603 47R PM5 COL
1332					RST SM 0603 47R PM5 COL
1333					RST SM 0603 47R PM5 COL
1334					RST SM 0603 47R PM5 COL
1335					RST SM 0603 47R PM5 COL
1336					RST SM 0603 47R PM5 COL
1337					RST SM 0603 47R PM5 COL
1338					RST SM 0603 47R PM5 COL
1339					RST SM 0603 47R PM5 COL
1340					RST SM 0603 47R PM5 COL
1341					RST SM 0603 47R PM5 COL
1342					RST SM 0603 47R PM5 COL
1343					RST SM 0603 47R PM5 COL
1344					RST SM 0603 47R PM5 COL
1345					RST SM 0603 47R PM5 COL
1346					RST SM 0603 47R PM5 COL
1347					RST SM 0603 47R PM5 COL
1348					RST SM 0603 47R PM5 COL
1349					RST SM 0603 47R PM5 COL
1350					RST SM 0603 47R PM5 COL
1351					RST SM 0603 47R PM5 COL
1352					RST SM 0603 47R PM5 COL
1353					RST SM 0603 47R PM5 COL
1354					RST SM 0603 47R PM5 COL
1355					RST SM 0603 47R PM5 COL
1356					RST SM 0603 47R PM5 COL
1357					RST SM 0603 47R PM5 COL
1358					RST SM 0603 47R PM5 COL
1359					RST SM 0603 47R PM5 COL
1360					RST SM 0603 47R PM5 COL
1361					RST SM 0603 47R PM5 COL
1362					RST SM 0603 47R PM5 COL
1363					RST SM 0603 47R PM5 COL
1364					RST SM 0603 47R PM5 COL
1365					RST SM 0603 47R PM5 COL
1366					RST SM 0603 47R PM5 COL
1367					RST SM 0603 47R PM5 COL
1368					RST SM 0603 47R PM5 COL
1369					RST SM 0603 47R PM5 COL
1370					RST SM 0603 47R PM5 COL
1371					RST SM 0603 47R PM5 COL
1372					RST SM 0603 47R PM5 COL
1373					RST SM 0603 47R PM5 COL
1374					RST SM 0603 47R PM5 COL
1375					RST SM 0603 47R PM5 COL
1376					RST SM 0603 47R PM5 COL
1377					RST SM 0603 47R PM5 COL
1378					RST SM 0603 47R PM5 COL
1379					RST SM 0603 47R PM5 COL
1380					RST SM 0603 47R PM5 COL
1381					RST SM 0603 47R PM5 COL
1382					RST SM 0603 47R PM5 COL
1383					RST SM 0603 47R PM5 COL
1384					RST SM 0603 47R PM5 COL
1385					RST SM 0603 47R PM5 COL
1386					RST SM 0603 47R PM5 COL
1387					RST SM 0603 47R PM5 COL
1388					RST SM 0603 47R PM5 COL
1389					RST SM 0603 47R PM5 COL
1390					RST SM 0603 47R PM5 COL
1391					RST SM 0603 47R PM5 COL
1392					RST SM 0603 47R PM5 COL
1393					RST SM 0603 47R PM5 COL
1394					RST SM 0603 47R PM5 COL
1395					RST SM 0603 47R PM5 COL
1396					RST SM 0603 47R PM5 COL
1397					RST SM 0603 47R PM5 COL
1398					RST SM 0603 47R PM5 COL
1399					RST SM 0603 47R PM5 COL
1400					RST SM 0603 47R PM5 COL

	LGE	SDI	FHP
CTRL-DISP1		RESET Semi standby: H Normal and off: L	CPU-GO On time: H Off time: Don't care
CTRL-DISP2(LCD_PWR_ON)	DISPEN On time: H Off time: Don't care		
CTRL-DISP3(Rev_Standby)		PDWIN On time: H Off time: Don't care	
CTRL-DISP4			PDP-GO On time: H Semi standby: L Off time: Don't care

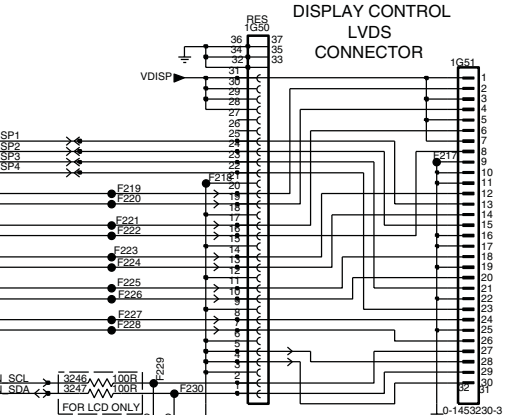

- 1201 D4
- 1210 H12
- 1211 H2
- 1212 H2
- 1213 J12
- 1214 J12
- 1215 L7
- 1216 L7
- 1217 B12
- 1218 B12
- 1219 B12
- 1220 B12
- 1221 B12
- 1222 B12
- 1223 B12
- 1224 B12
- 1225 B12
- 1226 B12
- 1227 B12
- 1228 B12
- 1229 B12
- 1230 B12
- 1231 B12
- 1232 B12
- 1233 B12
- 1234 B12
- 1235 B12
- 1236 B12
- 1237 B12
- 1238 B12
- 1239 B12
- 1240 B12
- 1241 K9
- 1242 B7
- 1243 A7
- 1244 B8
- 1245 K8
- 1246 B7
- 1247 B7
- 1248 B7
- 1249 B7
- 1250 B4
- 1251 B7
- 1252 B9
- 1253 C9
- 1254 C7
- 1255 D2
- 1256 D2
- 1257 J4
- 1258 J4
- 1259 J10
- 1260 J10
- 1261 J10
- 1262 J10
- 1263 K8
- 1264 L3
- 1265 D2
- 1266 A2
- 1267 B3
- 1268 K6
- 1269 K7
- 1270 K7
- 1271 K8
- 3241 K9
- 3242 K9
- 3243 K9
- 3244 A7
- 3245 K8
- 3246 J14
- 3247 J14
- 3248 B7
- 3250 J2
- 3251 J3
- 3252 K3
- 3253 K2
- 3254 K2
- 3255 B17
- 3256 J3
- 3257 J1
- 3258 K1
- 3259 B4
- 3260-1 B12
- 3260-2 B12
- 3260-3 B12
- 3260-4 B12
- 3260-5 B12
- 3260-6 B12
- 3260-7 B12
- 3260-8 B12
- 3260-9 B12
- 3260-10 B12
- 3260-11 B12
- 3260-12 B12
- 3260-13 B12
- 3260-14 B12
- 3260-15 B12
- 3260-16 B12
- 3260-17 B12
- 3260-18 B12
- 3260-19 B12
- 3260-20 B12
- 3260-21 B12
- 3260-22 B12
- 3260-23 B12
- 3260-24 B12
- 3260-25 B12
- 3260-26 B12
- 3260-27 B12
- 3260-28 B12
- 3260-29 B12
- 3260-30 B12
- 3260-31 B12
- 3260-32 B12
- 3260-33 B12
- 3260-34 B12
- 3260-35 B12
- 3260-36 B12
- 3260-37 B12
- 3260-38 B12
- 3260-39 B12
- 3260-40 B12
- 3260-41 B12
- 3260-42 B12
- 3260-43 B12
- 3260-44 B12
- 3260-45 B12
- 3260-46 B12
- 3260-47 B12
- 3260-48 B12
- 3260-49 B12
- 3260-50 B12
- 3260-51 B12
- 3260-52 B12
- 3260-53 B12
- 3260-54 B12
- 3260-55 B12
- 3260-56 B12
- 3260-57 B12
- 3260-58 B12
- 3260-59 B12
- 3260-60 B12
- 3260-61 B12
- 3260-62 B12
- 3260-63 B12
- 3260-64 B12
- 3260-65 B12
- 3260-66 B12
- 3260-67 B12
- 3260-68 B12
- 3260-69 B12
- 3260-70 B12
- 3260-71 B12
- 3260-72 B12
- 3260-73 B12
- 3260-74 B12
- 3260-75 B12
- 3260-76 B12
- 3260-77 B12
- 3260-78 B12
- 3260-79 B12
- 3260-80 B12
- 3260-81 B12
- 3260-82 B12
- 3260-83 B12
- 3260-84 B12
- 3260-85 B12
- 3260-86 B12
- 3260-87 B12
- 3260-88 B12
- 326

B04C AUDIO PROCESSOR

B04C

A
B
C
D
E
F

A
B
C
D
E
F

- 1411 B3
- 1421 D4
- 2408 A4
- 1422 D4
- 2409 A4
- 1423 E4
- 2410 A4
- 1424 E4
- 2411 A2
- 1425 F4
- 2412 A4
- 1426 A3
- 2413 A6
- 1427 C4
- 2414 B2
- 1428 C4
- 2415 B3
- 1429 C2
- 2416 B3
- 1430 C2
- 2417 B7
- 1431 D4
- 2418 B7
- 1432 D2
- 2419 C3
- 2420 C6
- 2421 C7
- 2422 C7
- 2423 C6
- 2424 D7
- 2425 D7
- 2426 D7
- 2427 D7
- 2428 D6
- 2429 D7
- 2430 D7
- 2431 D7
- 2432 D2
- 2433 D3
- 2434 E3
- 2435 E3
- 2436 E3
- 2437 F4
- 2438 F4
- 2439 A3
- 2440 A3
- 2441 A4
- 2442 A4
- 2443 A6
- 2444 A6
- 2445 E3
- 2446 C3
- 2447 C3
- 3402 A1
- 3410 C3
- 3411 C3
- 3416 E2
- 3417 D8
- 3418 D8
- 3419 D8
- 3420 D8
- 4401 A2
- 4402 A2
- 4403 E3
- 4406 F3
- 4407 C3
- 4408 C3
- 4409 D3
- 4410 D3
- 4411 D3
- 4412 D3
- 5401 A1
- 5402 B1
- 5403 E2
- 7410 A4
- 7411 B4
- F401 A4
- F402 A4
- F403 A5
- I412 C3
- I413 C3
- I414 C6
- I415 C6
- I416 D6
- I417 D6
- I418 D6
- I419 D6
- I420 D3

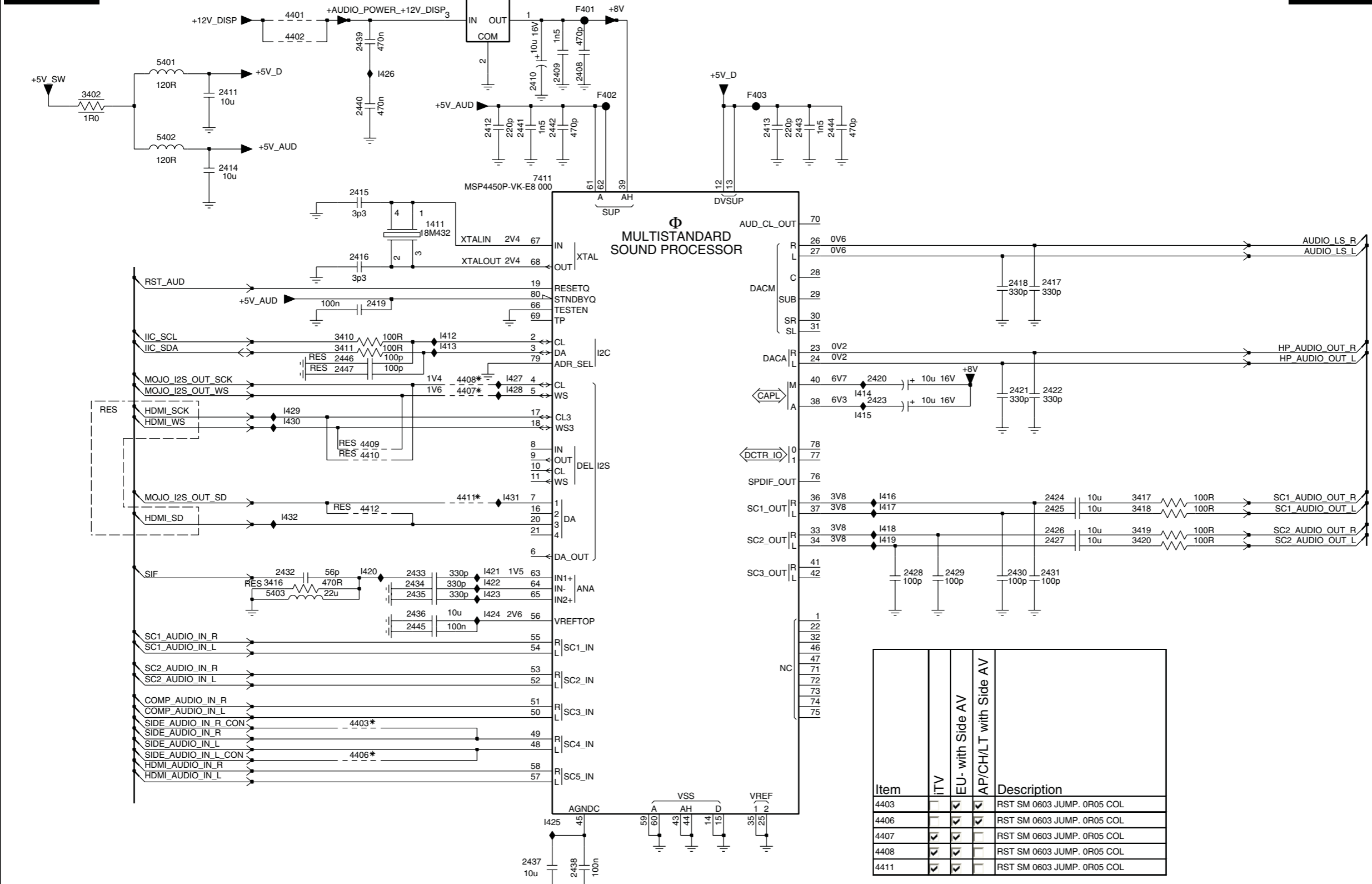

Item	iTV	EU - with Side AV	AP/CH/LT with Side AV	Description
4403				RST SM 0603 JUMP. 0R05 COL
4406				RST SM 0603 JUMP. 0R05 COL
4407				RST SM 0603 JUMP. 0R05 COL
4408				RST SM 0603 JUMP. 0R05 COL
4411				RST SM 0603 JUMP. 0R05 COL

1 2 3 4 5 6 7 8 9

B06A YPBPR & REAR IO

B06A

FOR NON SIDE IO / ITV

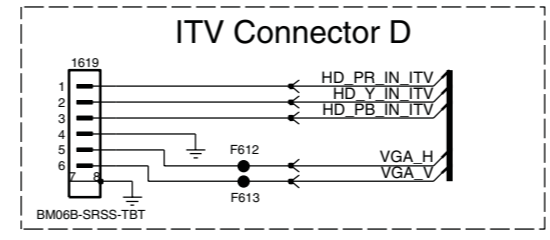
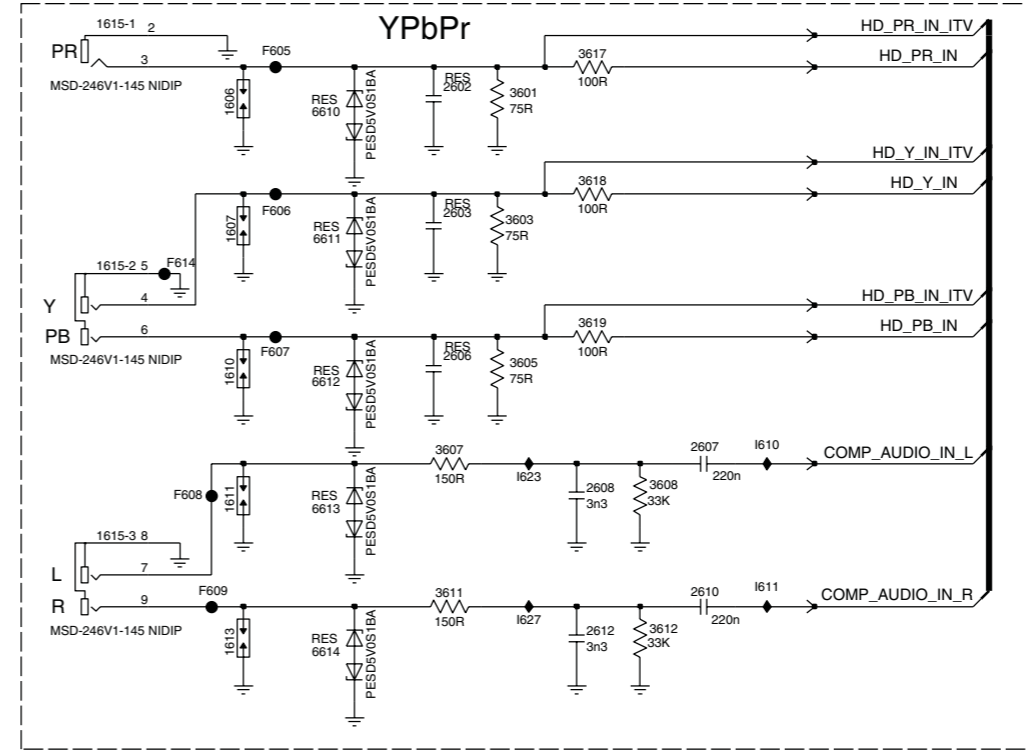
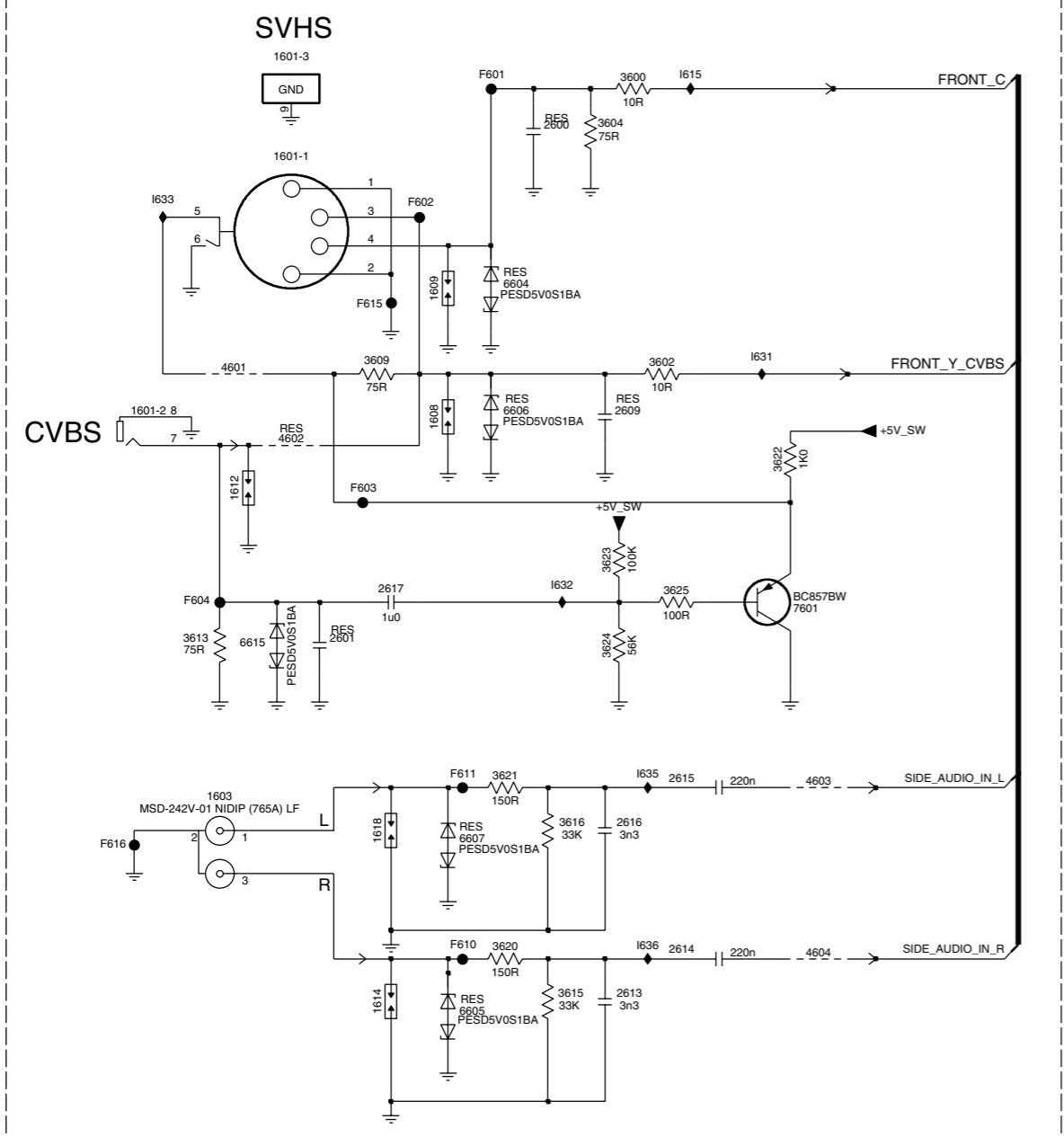

- 1601-1 B2
- 1601-2 D1
- 1601-3 B2
- 1603 E2
- 1606 B7
- 1607 C7
- 1608 D3
- 1609 C3
- 1610 C7
- 1611 D7
- 1612 D2
- 1613 D7
- 1614 F2
- 1615-1 B7
- 1615-2 C7
- 1615-3 D7
- 1618 F2
- 1619 E7
- 2600 B3
- 2601 E2
- 2602 B8
- 2603 B8
- 2606 C8
- 2607 C9
- 2608 D9
- 2609 D4
- 2610 D9
- 2612 D9
- 2613 F4
- 2614 F4
- 2615 E4
- 2616 F4
- 2617 D2
- 3600 B4
- 3601 B8
- 3602 C4
- 3603 B8
- 3604 B4
- 3605 C8
- 3607 D8
- 3608 D9
- 3609 C2
- 3611 D8
- 3612 D9
- 3613 E1
- 3615 F3
- 3616 F3
- 3617 B9
- 3618 B9
- 3619 C9
- 3620 F3
- 3621 E3
- 3622 D4
- 3623 D4
- 3624 E4
- 3625 D4
- 4601 C2
- 4602 D2
- 4603 E5
- 4604 F5
- 6604 C3
- 6605 G3
- 6606 D3
- 6607 F3
- 6610 B8
- 6611 C8
- 6612 C8
- 6613 D8
- 6614 D8
- 6615 E2
- 7601 D4
- F601 B3
- F602 C3
- F603 D2
- F604 D1
- F605 B7
- F606 B7
- F607 C7
- F608 D7
- F609 D7
- F610 F3
- F611 E3
- F612 F7
- F613 F7
- F614 C7
- F615 C2
- F616 F1
- I610 C10
- I611 D10
- I615 B4
- I623 D9
- I627 D9
- I631 C4
- I632 D3
- I633 B1
- I635 E4
- I636 F4

B06B IO - SCART 1 & 2

B06B

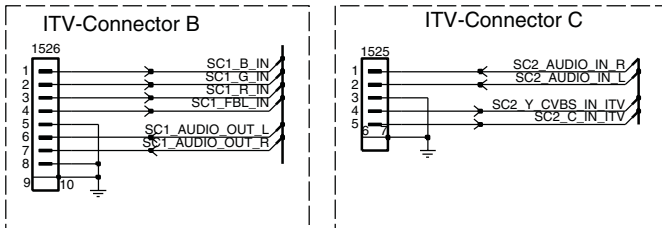

Item	non-ITV	iTV Analog	iTV-Digital	Description
1504	✓	✓	✓	SOC EURO V 21P F BK R-GRND B
1506	✓	✓	✓	SOC EURO V 21P F BK R-GRND B
1525	✓	✓	✓	CON V 5P M 1.00 SM SR R
1526	✓	✓	✓	CON V 8P M 1.00 SM SR R
3516	✓	✓	✓	RST SM 0603 100R PM5 COL
	✓	✓	✓	RST SM 0603 680R PM5 COL
3523	✓	✓	✓	RST SM 0603 100R PM5 COL
	✓	✓	✓	RST SM 0603 680R PM5 COL
3528	✓	✓	✓	RST SM 0603 100R PM5 COL
	✓	✓	✓	RST SM 0603 680R PM5 COL

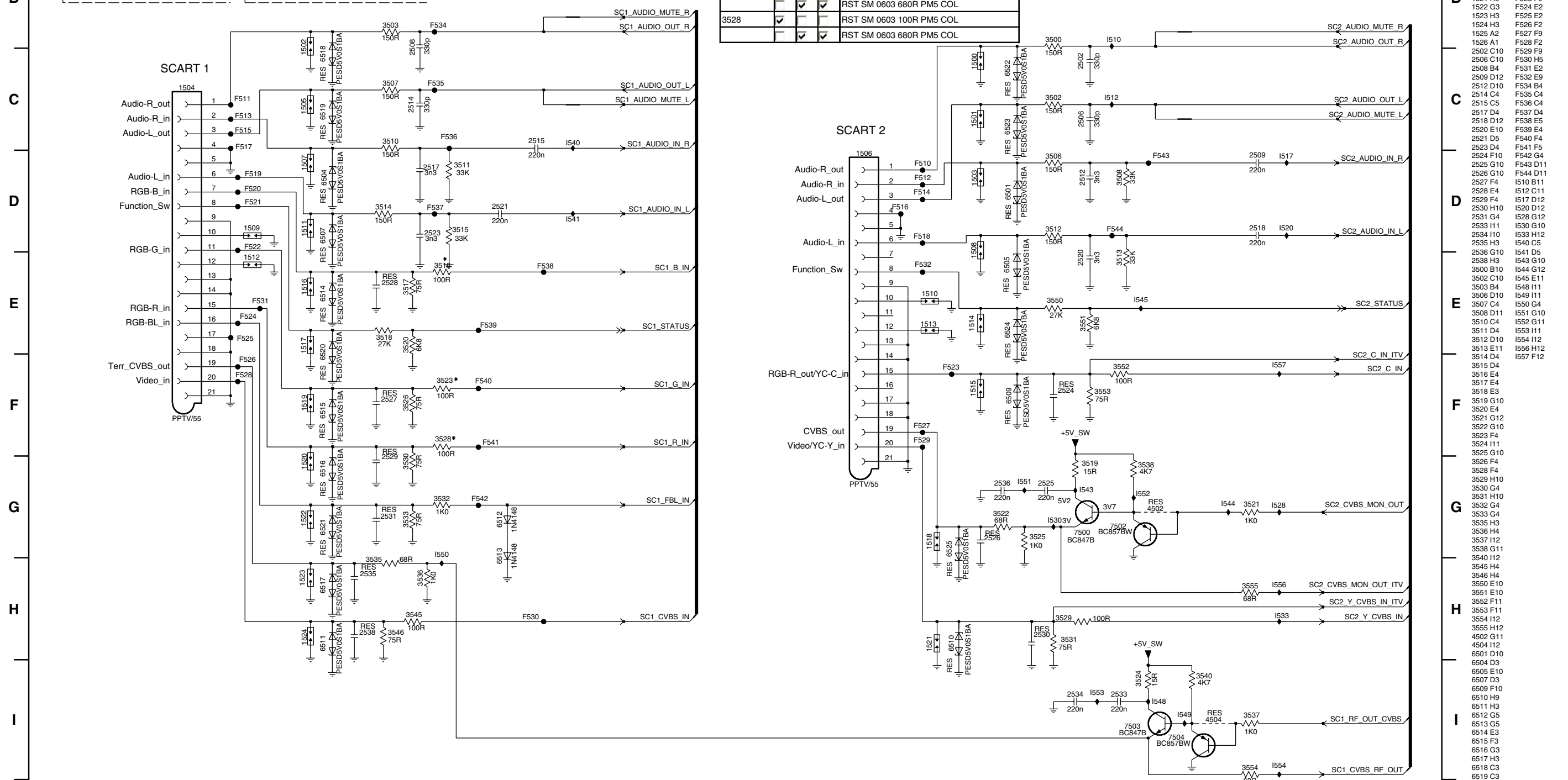

- 1500 C9
- 1501 C9
- 1502 C3
- 1503 D9
- 1504 C2
- 1505 C3
- 1506 D8
- 1507 D3
- 1508 E9
- 1509 D2
- 1510 E9
- 1511 D3
- 1512 E2
- 1513 E9
- 1514 E9
- 1515 F9
- 1516 F3
- 1517 E3
- 1518 G9
- 1519 F3
- 1520 G3
- 1521 H9
- 1522 G3
- 1523 H3
- 1524 H3
- 1525 A2
- 1526 A1
- 2502 C10
- 2506 C10
- 2508 B4
- 2509 D12
- 2512 D10
- 2514 C4
- 2515 C5
- 2517 D4
- 2518 D12
- 2520 E10
- 2521 D5
- 2523 D4
- 2524 F10
- 2525 G10
- 2526 G10
- 2527 F4
- 2528 E4
- 2529 F4
- 2530 H10
- 2531 G4
- 2533 I11
- 2534 I10
- 2538 H3
- 3500 B10
- 3502 C10
- 3503 B4
- 3507 C4
- 3508 D11
- 3510 C4
- 3511 D4
- 3512 D10
- 3513 E11
- 3514 D4
- 3515 D4
- 3516 E4
- 3517 E4
- 3518 E3
- 3519 G10
- 3520 E4
- 3521 G12
- 3522 G10
- 3523 F4
- 3524 I11
- 3525 G10
- 3526 F4
- 3528 F4
- 3529 H10
- 3530 G4
- 3531 H10
- 3532 G4
- 3533 G4
- 3535 H3
- 3536 H4
- 3537 I2
- 3538 G11
- 3540 I12
- 3545 H4
- 3546 H4
- 3550 E10
- 3551 E10
- 3552 F11
- 3553 F11
- 3554 I12
- 3555 H12
- 4502 G11
- 4504 I12
- 6501 D10
- 6504 D3
- 6505 E10
- 6507 D3
- 6509 F10
- 6510 H9
- 6511 H3
- 6512 G5
- 6513 G5
- 6514 E3
- 6515 F3
- 6516 G3
- 6517 H3
- 6518 C3
- 6519 C3
- 6520 E3
- 6521 G3
- 6522 C10
- 6523 C10
- 6524 E10
- 6525 G9
- 7500 G10
- 7502 G11
- 7503 I11
- 7504 I11
- 7510 D9
- 7511 C2
- 7512 D9
- 7513 C2
- 7514 D9
- 7515 C2
- 7516 D9
- 7517 C2
- 7518 D2
- 7520 D2
- 7521 D2
- 7522 D2
- 7523 F9
- 7524 E2
- 7525 E2
- 7526 F2
- 7527 F9
- 7528 F2
- 7529 F9
- 7530 H5
- 7531 E2
- 7532 E9
- 7534 B4
- 7535 C4
- 7536 C4
- 7537 D4
- 7538 E5
- 7539 E4
- 7540 F4
- 7541 F5
- 7542 G4
- 7543 D11
- 7544 D11
- 7545 B11
- 7546 C11
- 7547 D12
- 7548 G12
- 7549 G10
- 7550 H12
- 7551 G10
- 7552 H12
- 7553 G10
- 7554 G12
- 7555 H12
- 7556 H12
- 7557 F12

B06C HDMI

B06C

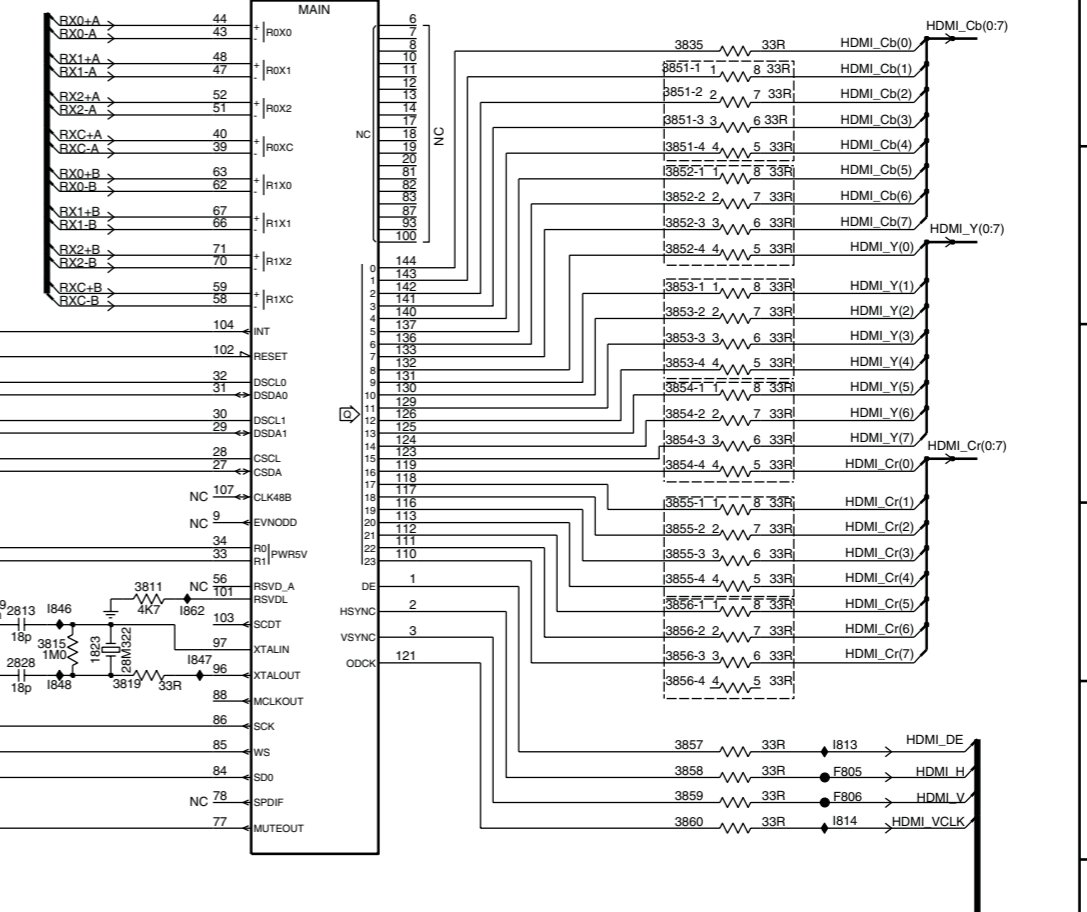
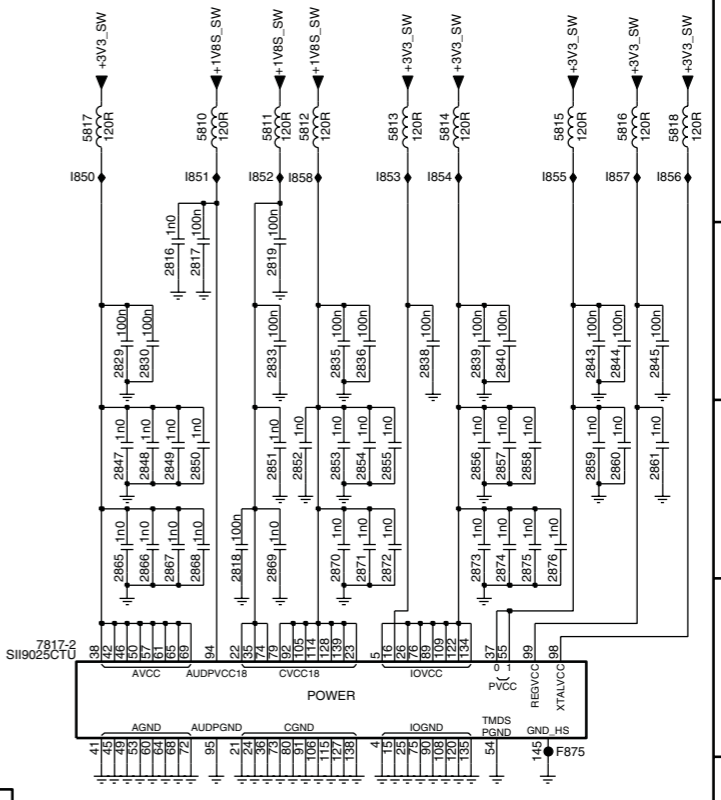
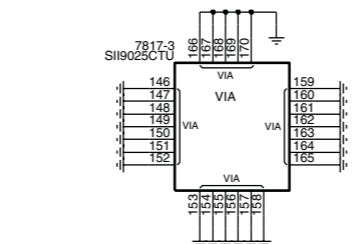
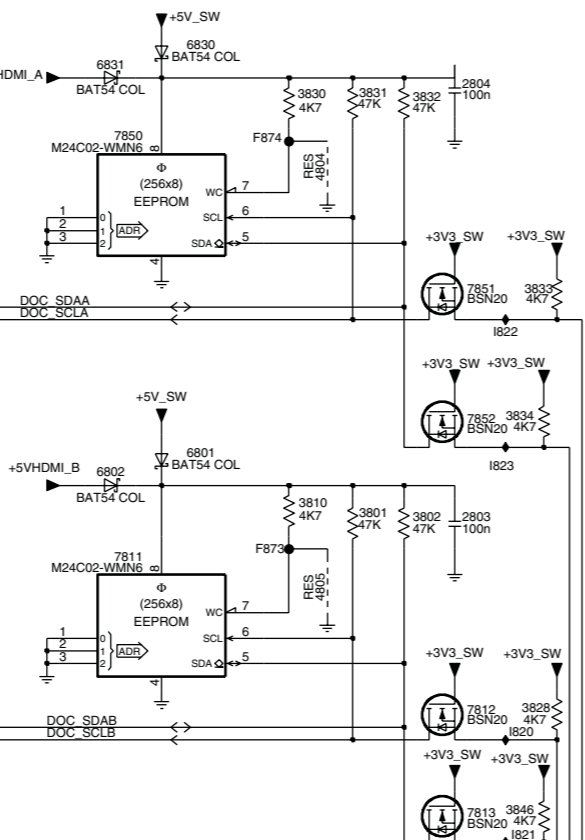
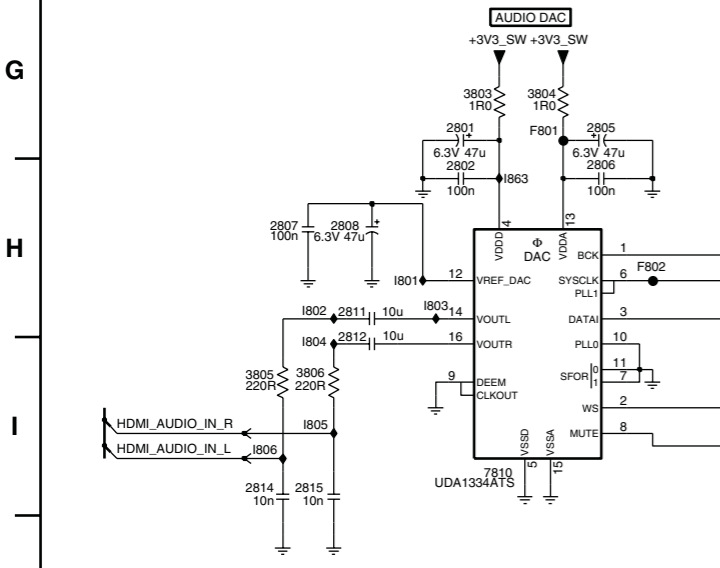
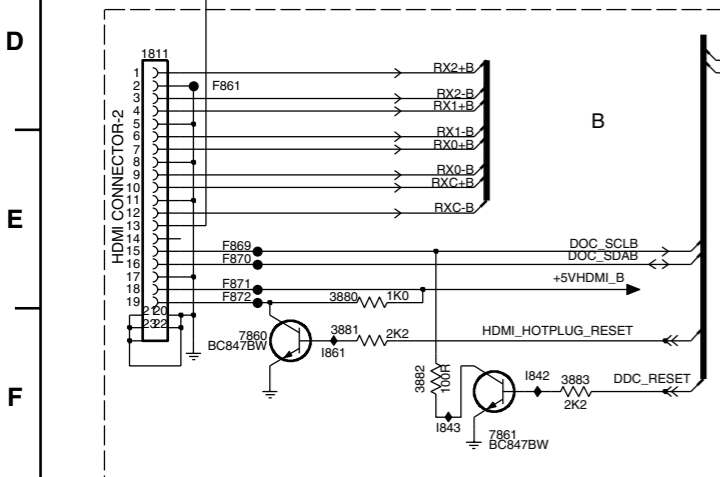
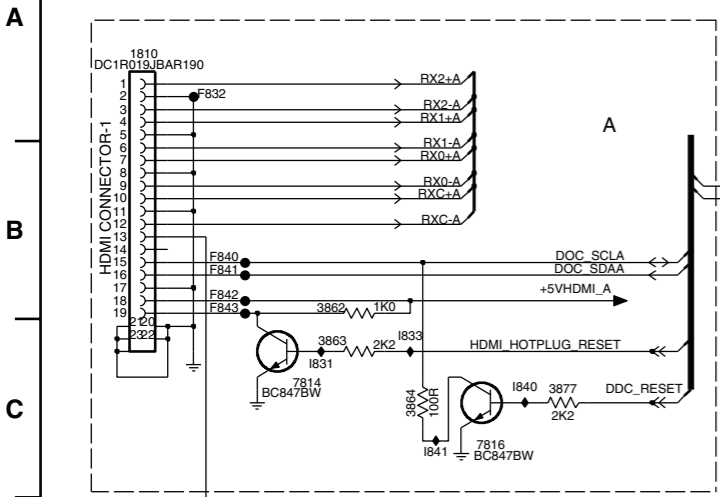

1810 A1	3881 F2
1811 D1	3882 F2
1823 H8	3883 F3
2801 G3	3884 I6
2802 H3	3885 I7
2803 C7	3886 I7
2804 A7	3896 G5
2805 G3	3897 G5
2806 H3	4802 H6
2807 H2	4803 H6
2808 H2	4804 A6
2809 H8	4805 C6
2810 H6	5810 A11
2811 H2	5811 A11
2812 I2	5812 A11
2813 H8	5813 A12
2814 I2	5814 A12
2815 I2	5815 A13
2816 B11	5816 A13
2817 B11	5817 A10
2818 C11	5818 A13
2819 B11	6801 C5
2828 H8	6802 C5
2829 B10	6830 A5
2830 B10	6831 A5
2832 B11	7810 I3
2833 C12	7811 C5
2836 B12	7812 D7
2838 B12	7813 E7
2839 B12	7814 C2
2840 B12	7816 C3
2843 B13	7817-1 E9
2844 B13	7817-2 D10
2845 B13	7817-3 C9
2847 C10	7824 H5
2848 C10	7825 H7
2849 C11	7850 A5
2850 C11	7851 B7
2851 C11	7852 B7
2852 C11	7860 F2
2853 C12	7861 F3
2854 C12	F801 G3
2855 C12	F802 H4
2856 C12	F805 I2
2857 C12	F806 I2
2858 C13	F802 A1
2859 C13	F840 B1
2860 C13	F841 B1
2861 C13	F842 B1
2865 C10	F843 B1
2866 C10	F850 H6
2868 C11	F851 H7
2868 C11	F861 D1
2869 C11	F869 E1
2870 C12	F870 E1
2871 C12	F871 E1
2872 C12	F872 E1
2873 C12	F873 C6
2874 C12	F874 A6
2875 C13	F875 D13
2876 C13	F876 F6
3801 C6	F877 G6
3802 C7	I801 H2
3803 G3	I802 H2
3804 G3	I803 H3
3805 I2	I804 I2
3806 I2	I805 I2
3807-1 I5	I806 I2
3807-3 I5	I813 I12
3807-4 I5	I814 I12
3807-4 I5	I820 D7
3809 H5	I821 E7
3810 C6	I822 B7
3811 H8	I823 C7
3815 H8	I828 I6
3819 I8	I831 C2
3828 D7	I833 C2
3830 A6	I840 C3
3831 A6	I841 C3
3832 A7	I842 F3
3833 B7	I843 F3
3834 B7	I844 G6
3835 E11	I845 G6
3846 E7	I846 H8
3850 H7	I847 H8
3851-1 E11	I848 H8
3851-2 E11	I850 A10
3851-3 E11	I851 A11
3851-4 F11	I852 A11
3852-1 F11	I853 A12
3852-2 F11	I854 A12
3852-3 F11	I855 A13
3852-4 F11	I856 A13
3853-1 F11	I857 A13
3853-2 F11	I858 A11
3853-3 G11	I861 F2
3853-4 G11	I862 H9
3854-1 G11	I863 H3
3854-2 G11	I864 I7
3854-3 G11	I865 I7
3854-4 G11	I866 I7
3855-1 H11	
3855-2 H11	
3855-3 H11	
3855-4 H11	
3856-1 H11	
3856-2 H11	
3856-3 H11	
3856-4 H11	
3857 H11	
3858 H11	
3859 H11	
3860 H11	
3861 H11	
3862 C2	
3863 C2	
3864 C2	
3877 C3	
3880 E2	

B06D HEADPHONE AMP & MUTING

B06D

A

B

C

D

E

F

A

B

C

D

E

F

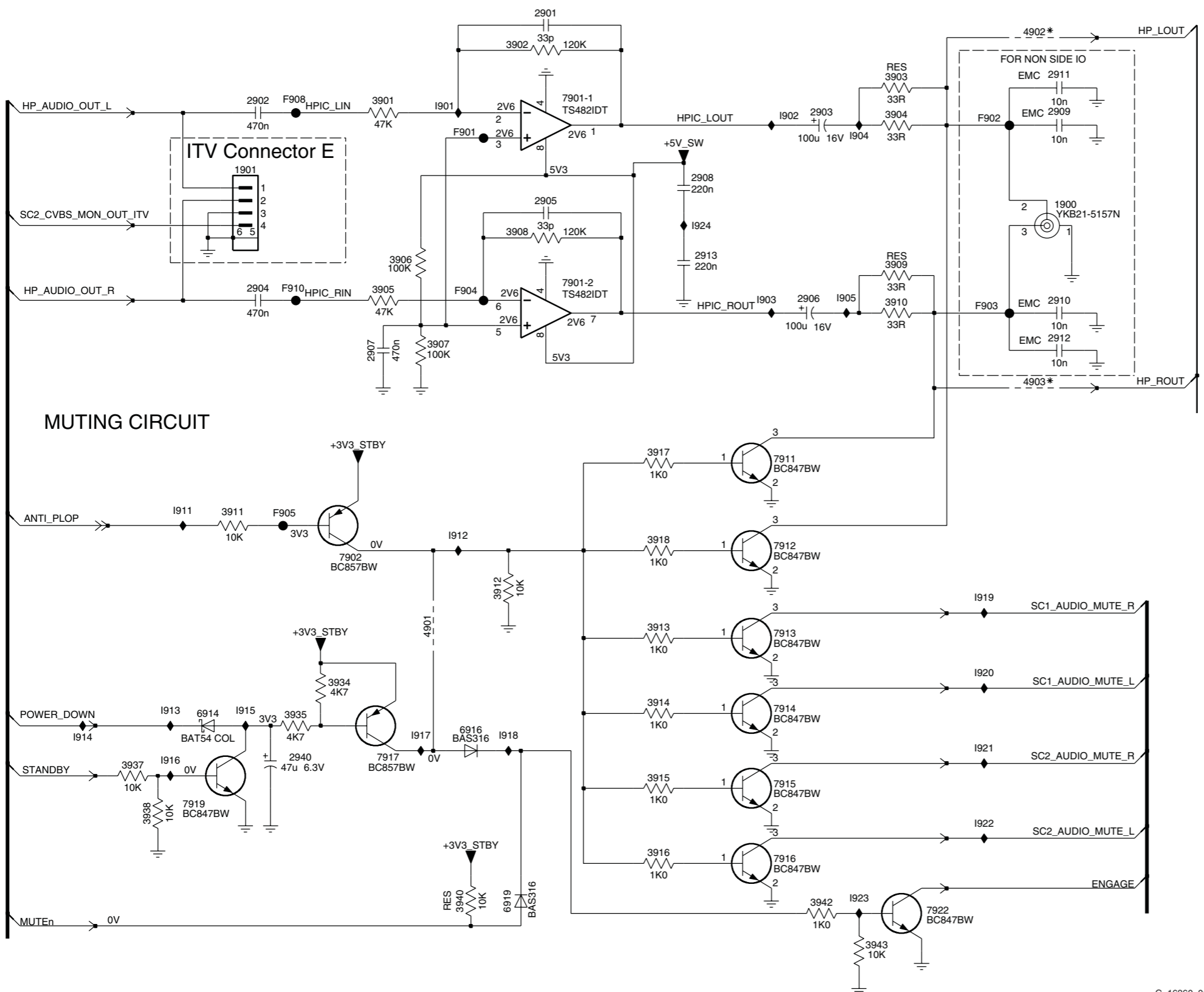

- 1900 B7
- 1901 B2
- 2901 A4
- 2902 A2
- 2903 B5
- 2904 C2
- 2905 B4
- 2906 C5
- 2907 C3
- 2908 B5
- 2909 A7
- 2910 C7
- 2911 A7
- 2912 C7
- 2913 B5
- 2940 E2
- 3901 A3
- 3902 A4
- 3903 A6
- 3904 B3
- 3905 C3
- 3906 B3
- 3907 C3
- 2903
- 3908 B4
- 2904
- 2905
- 3909 B6
- 2906
- 3910 C6
- 3911 D2
- 2907
- 3912 D4
- 2909
- 3913 D4
- 2910
- 3914 E4
- 2911
- 3915 E4
- 2912
- 3916 F4
- 3901
- 3902
- 3904
- 3905
- 3935 E2
- 3906
- 3907
- 3908
- 3910
- 3917
- 3918
- 4901 D3
- 4902
- 4903
- 7901
- 6914 E2
- 7911
- 6916 E3
- 6919 F4
- 7901-1 A4
- 7902 D3
- 7911 C5
- 7913 D5
- 7914 E5
- 7915 E5
- 7916 F5
- 7917 E3
- 7919 E2
- 7922 F6
- F901 B3
- F902 B6
- F903 C6
- F904 C3
- F905 D2
- F908 A2
- F910 B2
- I901 A3
- I902 B5
- I903 C5
- I904 B6
- I905 C5
- I911 D2
- I912 D3
- I913 E2
- I914 E1

Item	EUTV	non-ITV	US ITV	Description
1901	✓	✓	✓	CON V 4P M 1.00 SM SR R
2901	✓	✓	✓	CER1 0603 NP0 50V 33P COL
2902	✓	✓	✓	CER2 0603 Y5V 10V 470N COL
2903	✓	✓	✓	ELCAP SM 16V 100U PM20 COL R
2904	✓	✓	✓	CER2 0603 Y5V 10V 470N COL
2905	✓	✓	✓	CER1 0603 NP0 50V 33P COL
2906	✓	✓	✓	ELCAP SM 16V 100U PM20 COL R
2907	✓	✓	✓	CER2 0603 Y5V 10V 470N COL
2909	✓	✓	✓	CER2 0603 X7R 50V 10N COL
2910	✓	✓	✓	CER2 0603 X7R 50V 10N COL
2911	✓	✓	✓	CER2 0603 X7R 50V 10N COL
2912	✓	✓	✓	CER2 0603 X7R 50V 10N COL
3901	✓	✓	✓	RST SM 0603 47K PM5 COL
3902	✓	✓	✓	RST SM 0603 RC21 120K PM5 R
3904	✓	✓	✓	RST SM 0603 33R PM5 COL
3905	✓	✓	✓	RST SM 0603 47K PM5 COL
3906	✓	✓	✓	RST SM 0603 100K PM5 COL
3907	✓	✓	✓	RST SM 0603 100K PM5 COL
3908	✓	✓	✓	RST SM 0603 RC21 120K PM5 R
3910	✓	✓	✓	RST SM 0603 33R PM5 COL
3917	✓	✓	✓	RST SM 0603 1K PM5 COL
3918	✓	✓	✓	RST SM 0603 1K PM5 COL
4902	✓	✓	✓	RST SM 0603 JUMP. 0R05 COL
4903	✓	✓	✓	RST SM 0603 JUMP. 0R05 COL
7901	✓	✓	✓	IC SM TS482ID (ST00) R
7911	✓	✓	✓	TRA SIG SM BC847BW (COL) R
7912	✓	✓	✓	TRA SIG SM BC847BW (COL) R

B07 AUDIO

B07

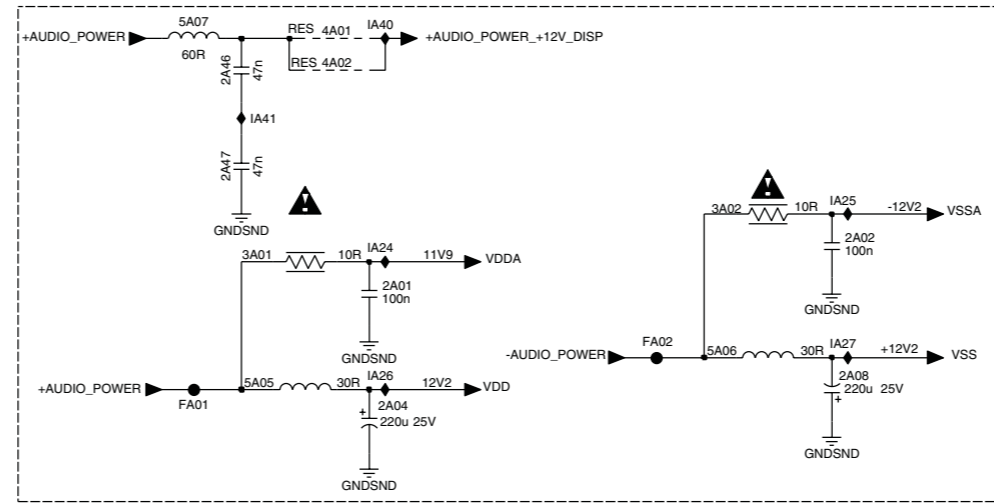

*	LCD	PDP
3A03	10K	6K9
3A04	12K	22K
3A06	10K	6K9
3A07	10K	6K9
3A08	12K	22K
3A11	10K	6K9

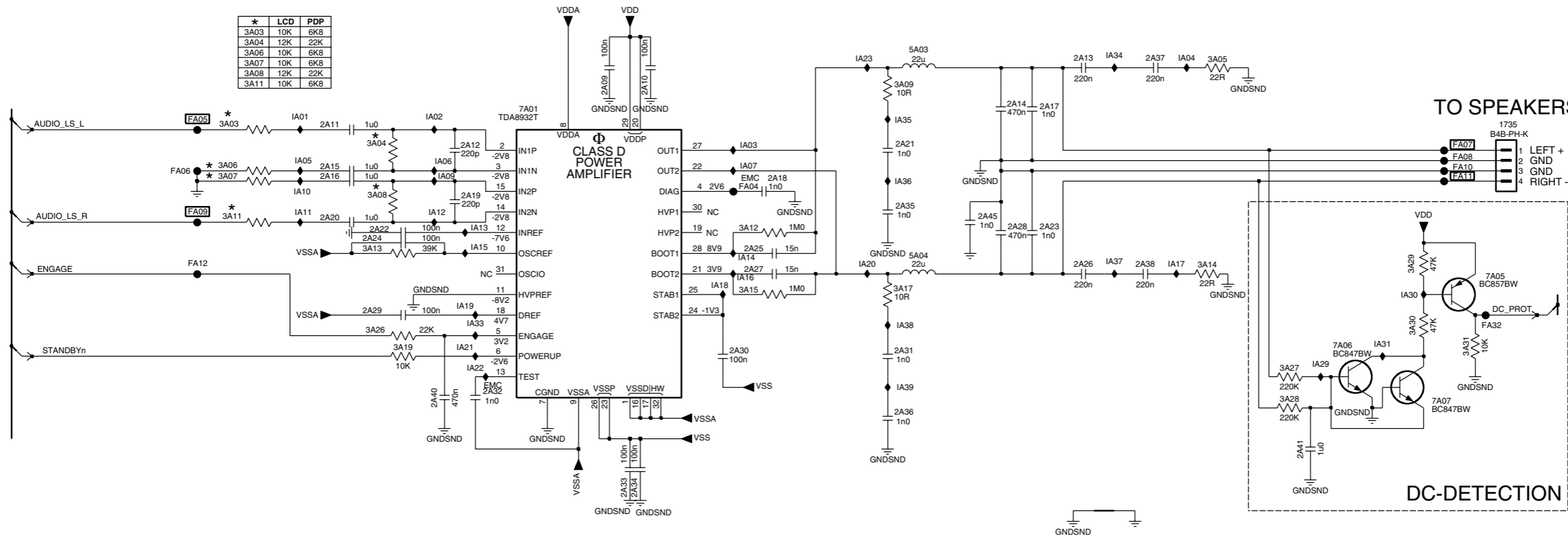

- 1735 D11
- 2A01 B7
- 2A02 B9
- 2A04 C7
- 2A08 B9
- 2A09 D5
- 2A10 D5
- 2A11 D3
- 2A12 D4
- 2A13 D8
- 2A14 D8
- 2A15 D3
- 2A16 D3
- 2A17 D8
- 2A18 D6
- 2A19 D4
- 2A20 E3
- 2A21 D7
- 2A22 E3
- 2A23 E8
- 2A24 E3
- 2A25 E6
- 2A26 E8
- 2A27 E6
- 2A28 E8
- 2A29 E3
- 2A30 F6
- 2A31 F7
- 2A32 F4
- 2A33 F5
- 2A34 F5
- 2A35 E7
- 2A36 F7
- 2A37 D8
- 2A38 E8
- 2A40 F3
- 2A41 F9
- 2A45 E7
- 2A46 A6
- 2A47 B6
- 3A01 B6
- 3A02 B8
- 3A03 D2
- 3A04 D3
- 3A05 D9
- 3A06 D2
- 3A07 D2
- 3A08 D3
- 3A09 D7
- 3A11 E2
- 3A12 E6
- 3A13 E3
- 3A14 E9
- 3A15 E6
- 3A17 E7
- 3A19 F3
- 3A26 E3
- 3A27 F9
- 3A28 F9
- 3A29 E10
- 3A30 E10
- 3A31 F11
- 4A01 A6
- 4A02 A6
- 5A03 C7
- 5A04 E7
- 5A05 B6
- 5A06 B8
- 5A07 A6
- 7A01 D4
- 7A05 E11
- 7A06 F10
- 7A07 F10
- FA01 C6
- FA02 B8
- FA04 D6
- FA05 D2
- FA06 D2
- FA07 D11
- FA08 D11
- FA09 E2
- FA10 D11
- FA11 D11
- FA12 E2
- FA32 E11
- IA01 D3
- IA02 D3
- IA03 D6
- IA04 D9
- IA05 D3
- IA06 D4
- IA07 D6
- IA09 D4
- IA10 D3
- IA11 E3
- IA12 E3
- IA13 E4
- IA14 E6
- IA15 E4
- IA16 E6
- IA17 E9
- IA18 E5
- IA19 E4
- IA20 E6
- IA21 F4
- IA22 F4
- IA23 D6
- IA24 B7
- IA25 B9
- IA26 B7
- IA27 B9
- IA29 F10
- IA30 E10
- IA31 E10
- IA33 E4
- IA34 C8
- IA35 D7
- IA36 D7
- IA37 E8
- IA38 E7
- IA39 F7
- IA40 A7
- IA41 A6

D REAR FACING SIDE I/O

D

A

B

C

D

E

F

A

B

C

D

E

F

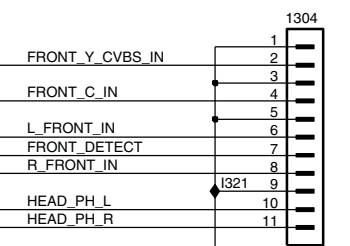
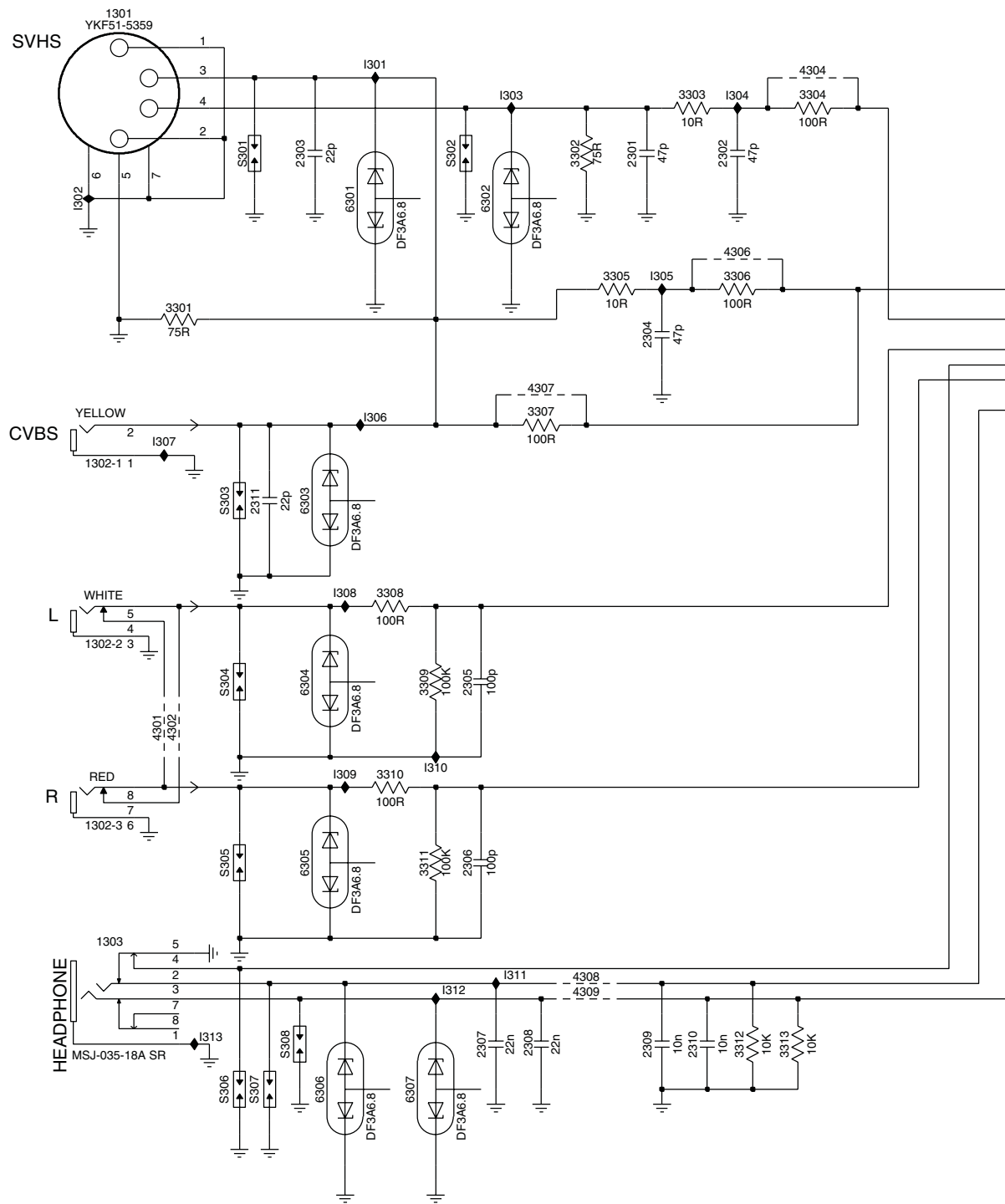

TO 1M36 OF
SSB BD
B03A

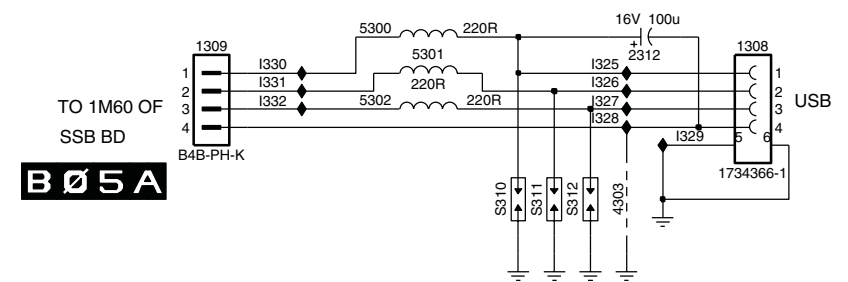
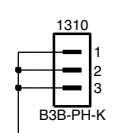

TO 1M60 OF
SSB BD
B05A

- 1301 A1
- 1302-1 C1
- 1302-2 D1
- 1302-3 E1
- 1303 B1
- 1304 B9
- 1308 E8
- 1309 E6
- 1310 C9
- 2301 B3
- 2302 B4
- 2303 B2
- 2304 B3
- 2305 D3
- 2306 E3
- 2307 F3
- 2308 F3
- 2309 F3
- 2310 F4
- 2311 C2
- 2312 E8
- 3301 B1
- 3302 B3
- 3303 A4
- 3304 A4
- 3305 B3
- 3306 B4
- 3307 C3
- 3308 D2
- 3309 D2
- 3310 D2
- 3311 E2
- 3312 F4
- 3313 F4
- 4301 D1
- 4302 D1
- 4303 E8
- 4304 A4
- 4306 B4
- 4307 C3
- 4308 E3
- 4309 E3
- 5300 E7
- 5301 E7
- 5302 E7
- 6301 B2
- 6302 B3
- 6303 C2
- 6304 D2
- 6305 E2
- 6306 F2
- 6307 F2
- I301 A2
- I302 B1
- I303 A3
- I304 A4
- I305 B4
- I306 C2
- I307 C1
- I308 D2
- I309 D2
- I310 D2
- I311 E3
- I312 E3
- I313 F1
- I314 B7
- I315 B7
- I316 B7
- I317 B7
- I318 C7
- I319 C7
- I320 C7
- I321 C8
- I325 E8
- I326 E8
- I327 E8
- I328 E8
- I329 E8
- I330 E6
- I331 E6
- I332 E6
- S301 B2
- S302 B3
- S303 C1
- S304 D1
- S305 E1
- S306 F1
- S307 F2
- S308 F2
- S310 E7
- S311 E7
- S312 E8

Keyboard Control Panel

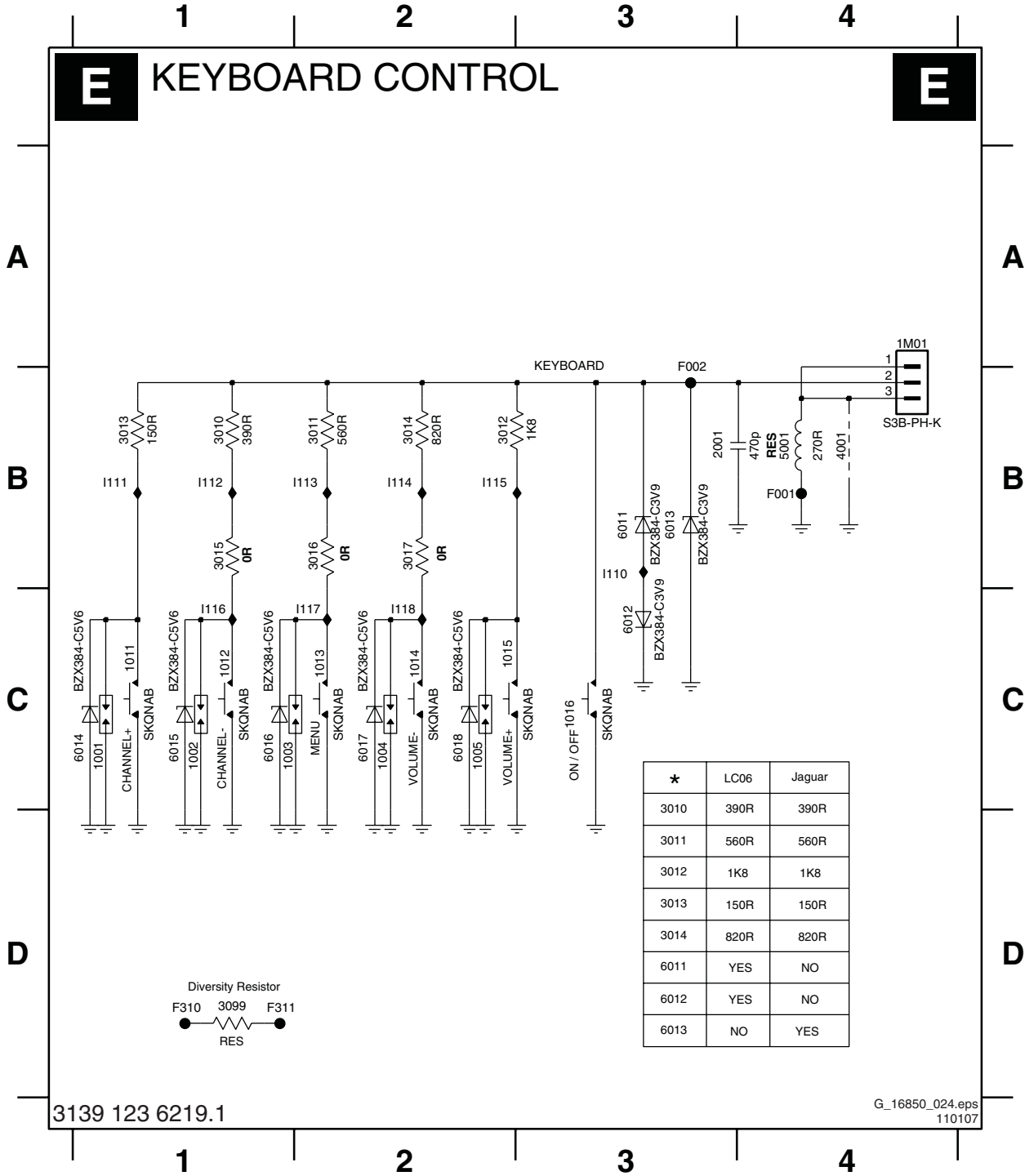

*	LC06	Jaguar
3010	390R	390R
3011	560R	560R
3012	1K8	1K8
3013	150R	150R
3014	820R	820R
6011	YES	NO
6012	YES	NO
6013	NO	YES

Front IR / LED Panel

1 2 3 4 5

J

IR/LED/LIGHT-SENSOR

J

A

B

C

D

E

F

A

B

C

D

E

F

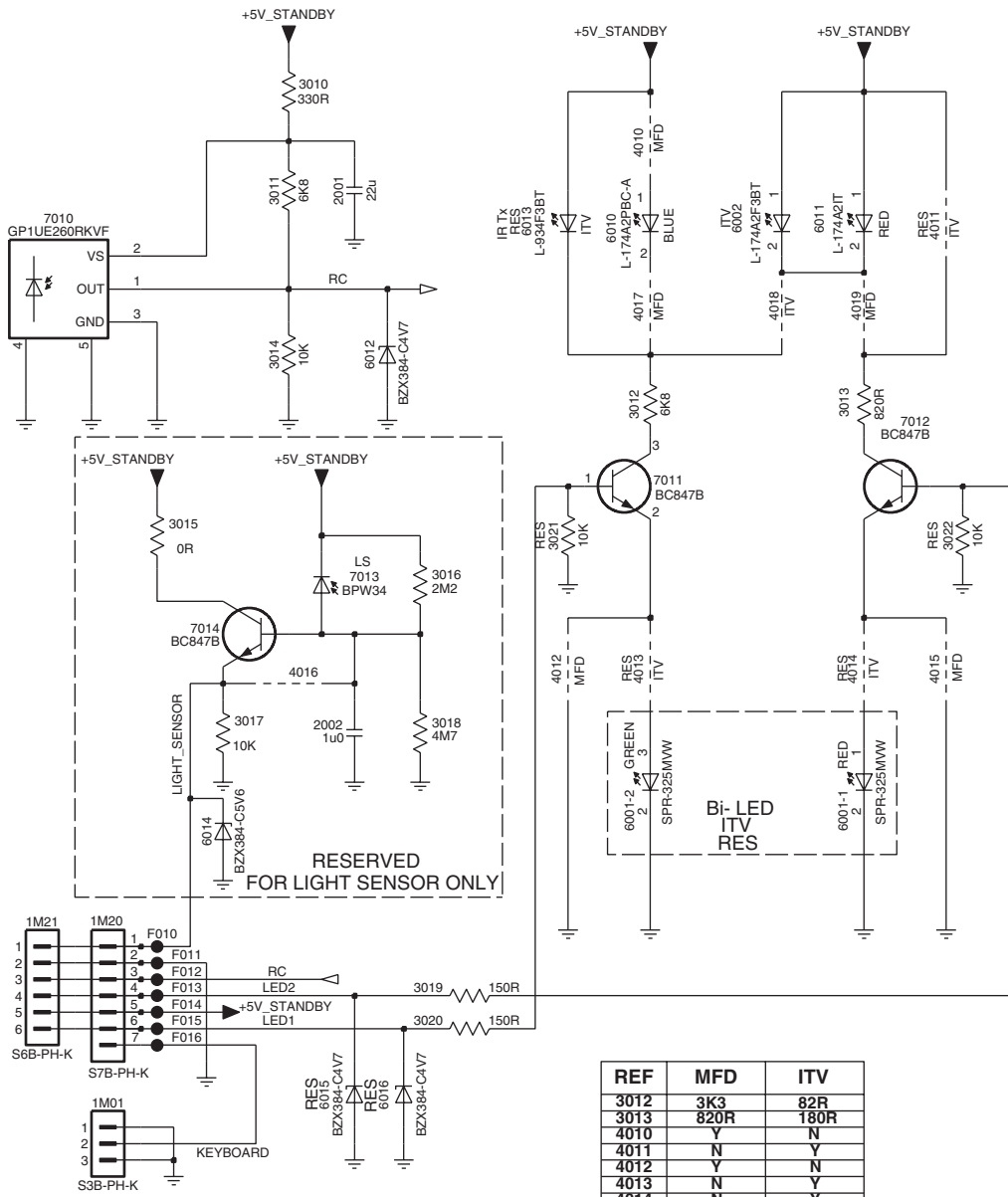

- 1M01 E1
- 1M20 E1
- 1M21 E1
- 2001 A2
- 2002 D2
- 3010 A2
- 3011 A2
- 3012 B4
- 3013 B4
- 3014 B2
- 3015 C2
- 3016 C3
- 3017 D2
- 3018 D3
- 3019 E3
- 3020 E3
- 3021 C3
- 3022 C5
- 4010 A4
- 4011 B5
- 4012 D3
- 4013 D4
- 4014 D5
- 4015 D5
- 4016 D2
- 4017 B4
- 4018 B4
- 4019 B5
- 6001-1 D5
- 6001-2 D4
- 6002 B4
- 6010 B3
- 6011 B4
- 6012 B2
- 6013 B3
- 6014 D2
- 6015 E2
- 6016 E2
- 7010 B1
- 7011 C4
- 7012 B5
- 7013 C2
- 7014 C2
- F010 E2
- F011 E2
- F012 E2
- F013 E2
- F014 E2
- F015 E2
- F016 E2

REF	MFD	ITV
3012	3K3	82R
3013	820R	180R
4010	Y	N
4011	N	Y
4012	Y	N
4013	N	Y
4014	N	Y
4015	Y	N
4017	Y	N
4018	N	Y
4019	Y	N
6001	N	BI-GR/RD
6002	N	IR ED
6010	BLUE LED	N
6011	RED LED	N

1 2 3 4 5