

Block Diagram Video

VIDEO

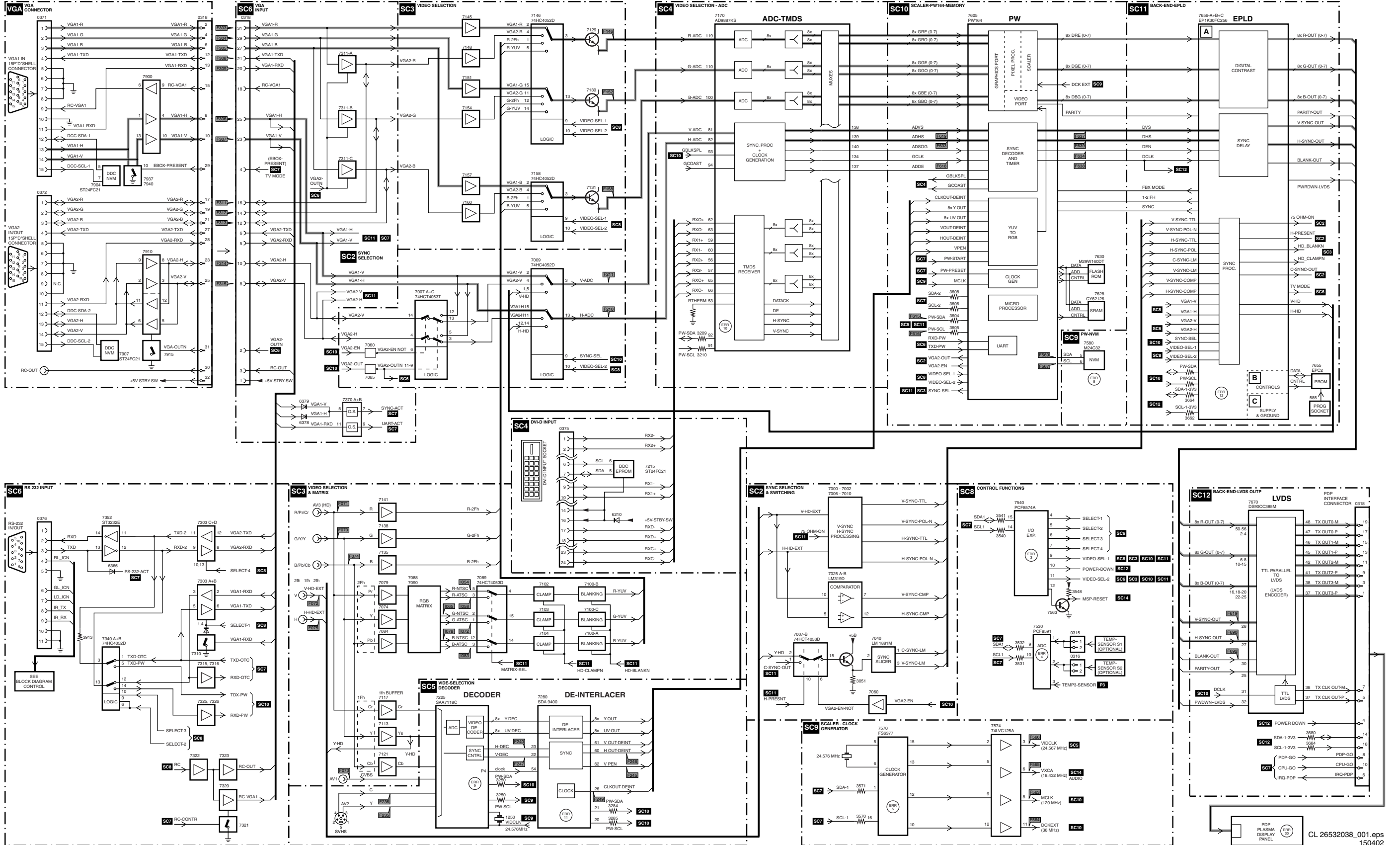

Block Diagram Audio

AUDIO

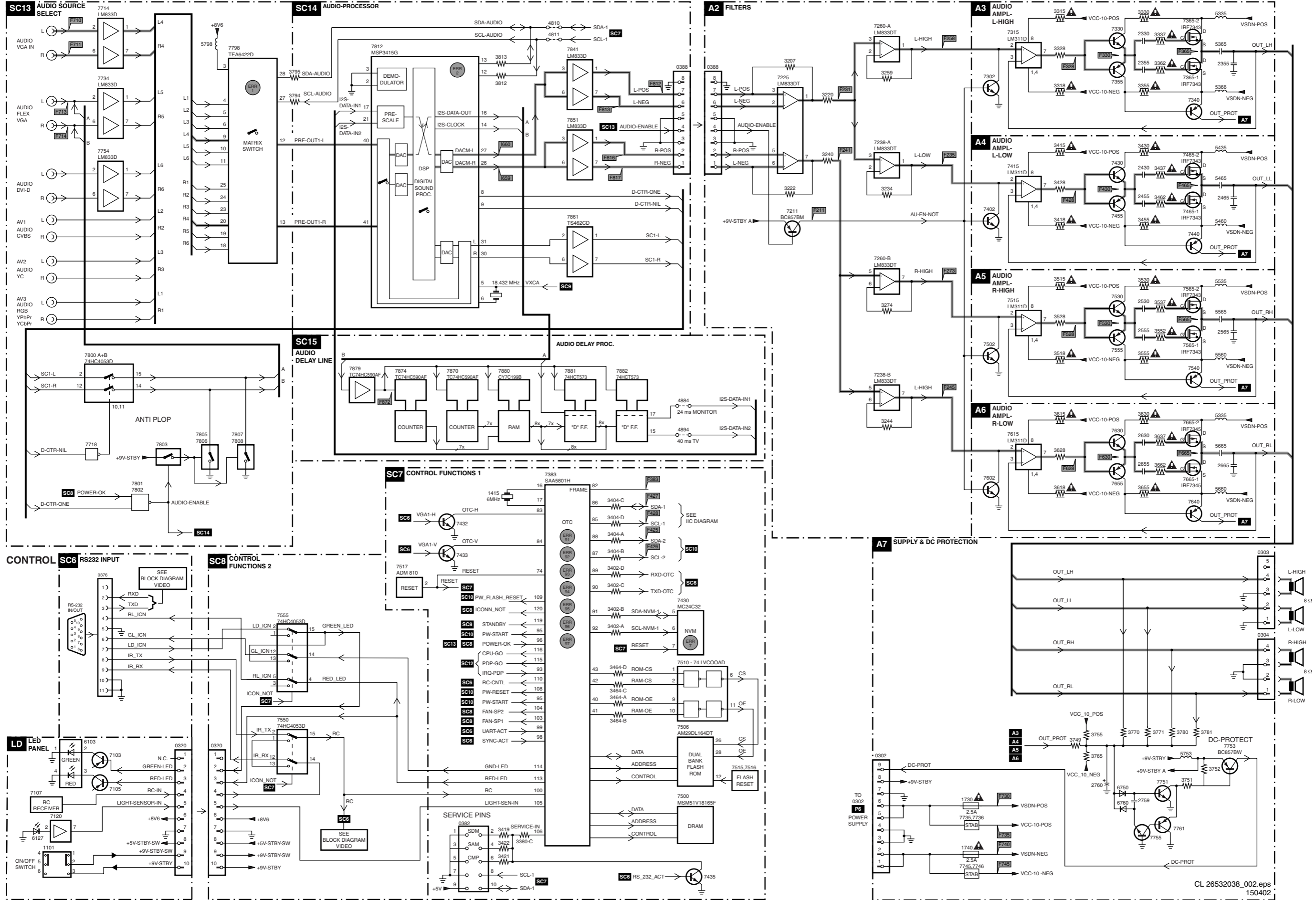

Power Lines Overview

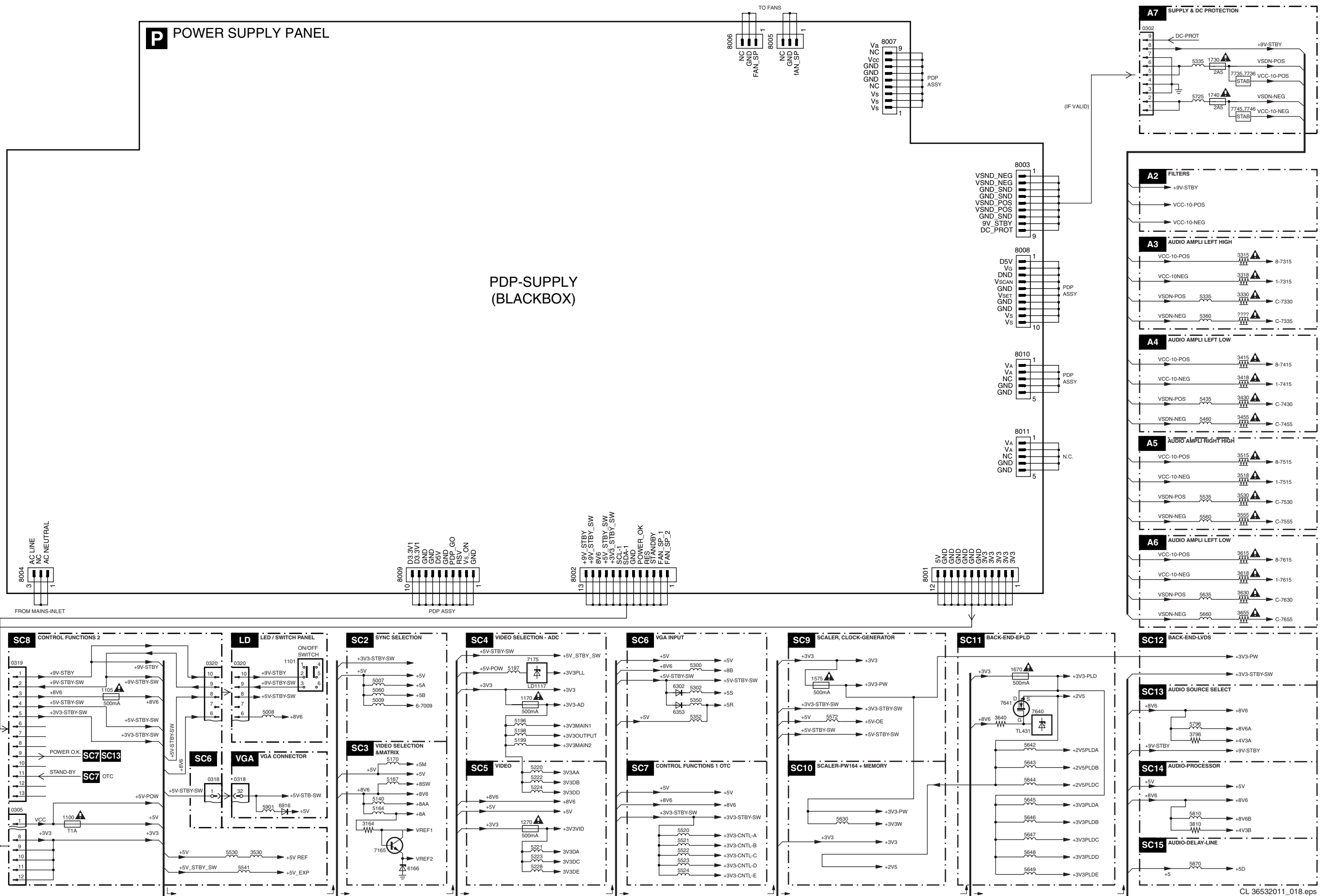

I²C-IC Overview

IIC

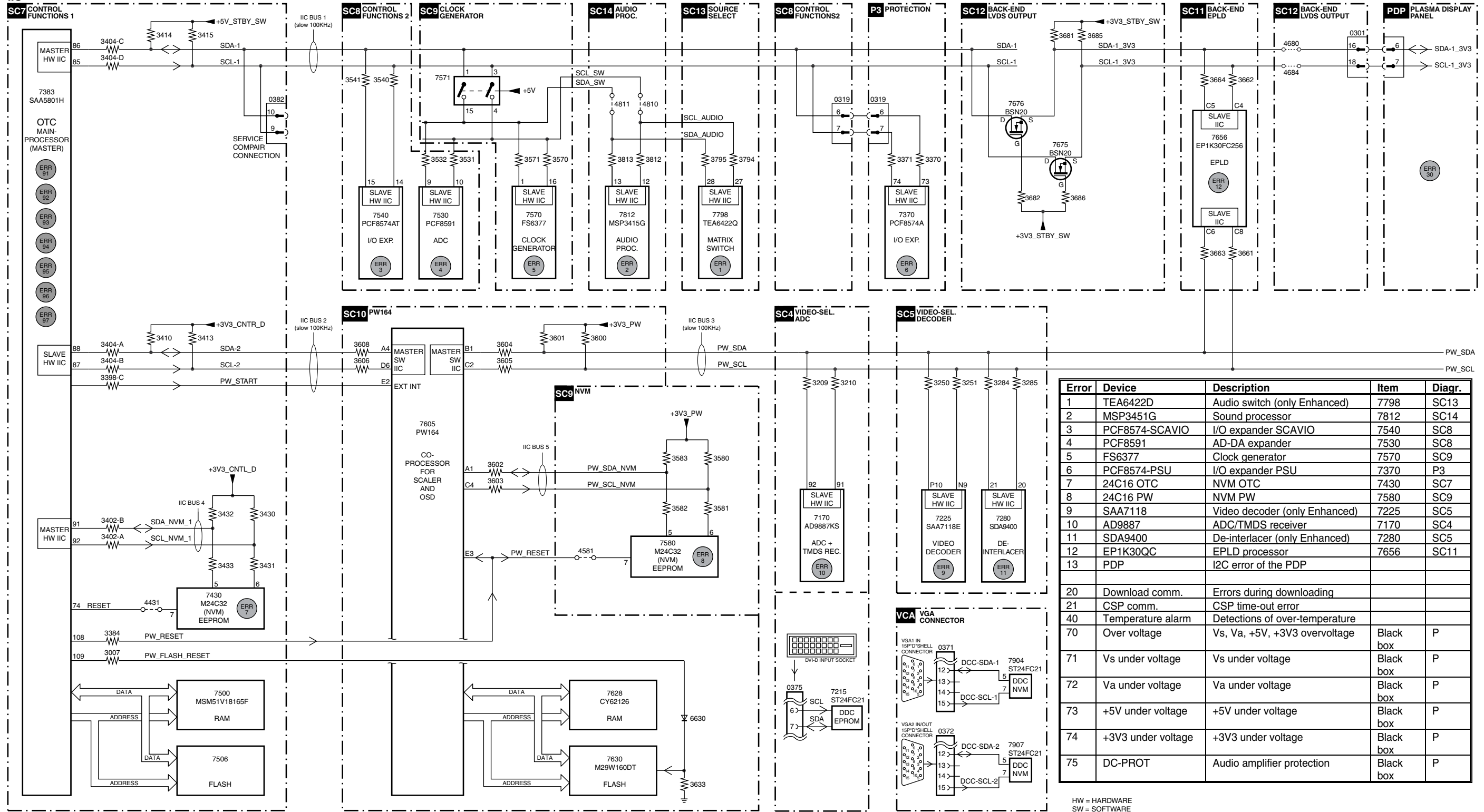

Error	Device	Description	Item	Diagr.
1	TEA6422D	Audio switch (only Enhanced)	7798	SC13
2	MSP3451G	Sound processor	7812	SC14
3	PCF8574-SCAVIO	I/O expander SCAVIO	7540	SC8
4	PCF8591	AD-DA expander	7530	SC8
5	FS6377	Clock generator	7570	SC9
6	PCF8574-PSU	I/O expander PSU	7370	P3
7	24C16 OTC	NVM OTC	7430	SC7
8	24C16 PW	NVM PW	7580	SC9
9	SAA7118	Video decoder (only Enhanced)	7225	SC5
10	AD9887	ADC/TMDS receiver	7170	SC4
11	SDA9400	De-interlacer (only Enhanced)	7280	SC5
12	EP1K30QC	EPLD processor	7656	SC11
13	PDP	I2C error of the PDP		
20	Download comm.	Errors during downloading		
21	CSP comm.	CSP time-out error		
40	Temperature alarm	Detections of over-temperature		
70	Over voltage	Vs, Va, +5V, +3V3 overvoltage	Black box	P
71	Vs under voltage	Vs under voltage	Black box	P
72	Va under voltage	Va under voltage	Black box	P
73	+5V under voltage	+5V under voltage	Black box	P
74	+3V3 under voltage	+3V3 under voltage	Black box	P
75	DC-PROT	Audio amplifier protection	Black box	P

HW = HARDWARE
SW = SOFTWARE

Testpoint Overview: Audio Amplifier Panel

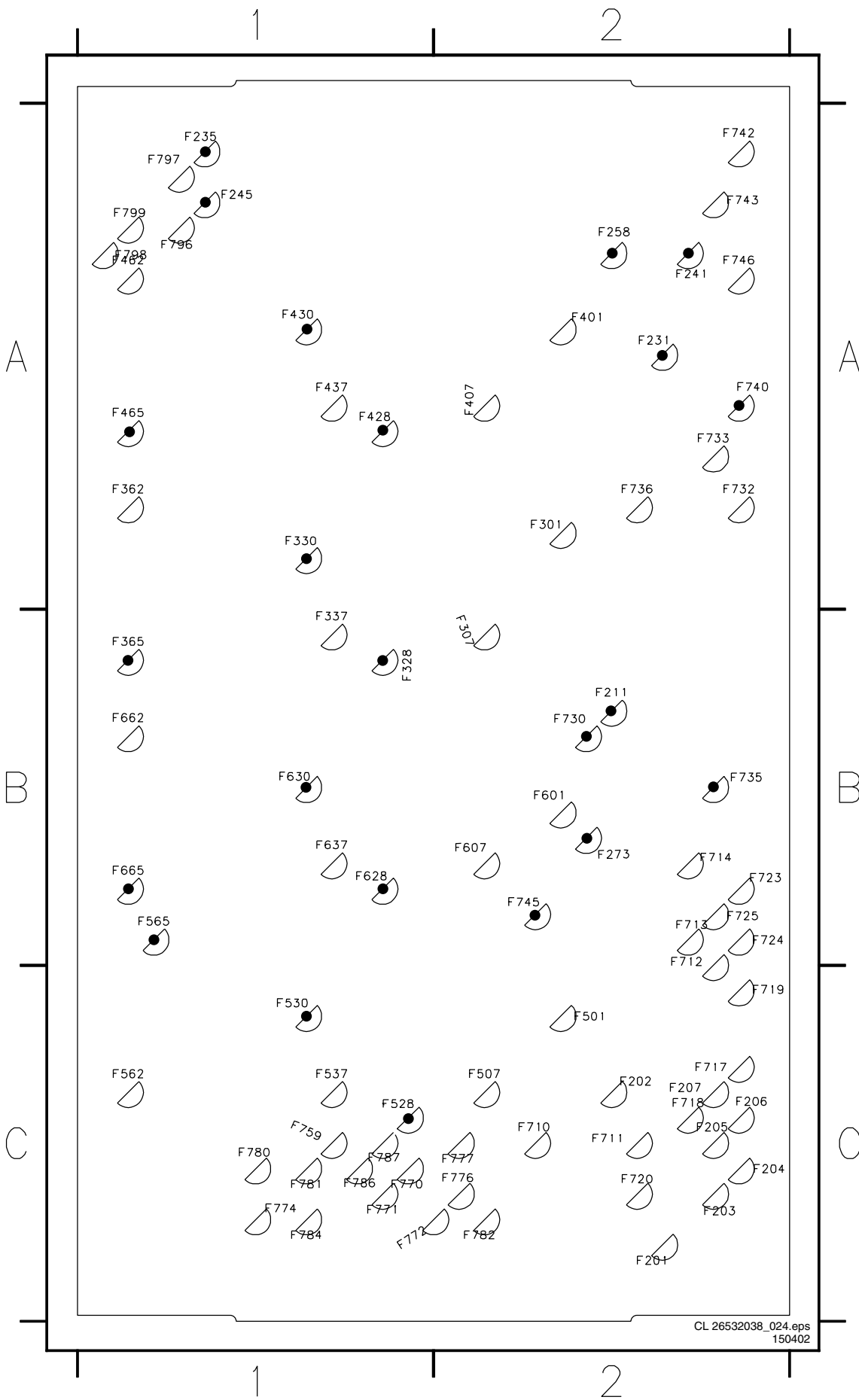

- F201 C2 F718 C2
- F201 C2 F718 C2
- F202 C2 F719 C2
- F203 C2 F720 C2
- F203 C2 F720 C2
- F204 C2 F723 B2
- F204 C2 F723 B2
- F205 C2 F724 B2
- F205 C2 F724 B2
- F206 C2 F725 B2
- F206 C2 F725 B2
- F207 C2 F730 B2
- F207 C2 F730 B2
- F211 B2 F732 A2
- F211 B2 F732 A2
- F231 A2 F733 A2
- F231 A2 F733 A2
- F235 A1 F735 B2
- F235 A1 F735 B2
- F241 A2 F736 A2
- F241 A2 F736 A2
- F245 A1 F740 A2
- F245 A1 F740 A2
- F258 A2 F742 A2
- F258 A2 F742 A2
- F273 B2 F743 A2
- F273 B2 F743 A2
- F301 A2 F745 B2
- F301 A2 F745 B2
- F307 B2 F746 A2
- F307 B2 F746 A2
- F328 B1 F759 C1
- F328 B1 F759 C1
- F330 A1 F770 C1
- F330 A1 F770 C1
- F365 B1 F771 C1
- F365 B1 F771 C1
- F401 A2 F772 C1
- F401 A2 F772 C1
- F407 A2 F774 C1
- F407 A2 F774 C1
- F428 A1 F776 C2
- F428 A1 F776 C2
- F430 A1 F777 C2
- F430 A1 F777 C2
- F465 A1 F780 C1
- F465 A1 F780 C1
- F501 C2 F781 C1
- F501 C2 F781 C1
- F507 C2 F782 C2
- F507 C2 F782 C2
- F528 C1 F784 C1
- F528 C1 F784 C1
- F530 C1 F786 C1
- F530 C1 F786 C1
- F565 B1 F787 C1
- F565 B1 F787 C1
- F601 B2 F796 A1
- F601 B2 F796 A1
- F607 B2 F797 A1
- F607 B2 F797 A1
- F628 B1 F798 A1
- F628 B1 F798 A1
- F630 B1 F799 A1
- F630 B1 F799 A1
- F665 B1 F799 A1
- F665 B1 F799 A1
- F710 C2
- F710 C2
- F711 C2
- F711 C2
- F712 B2
- F712 B2
- F713 B2
- F713 B2
- F714 B2
- F714 B2
- F717 C2
- F717 C2
- F717 C2
- F717 C2

Testpoint Overview: Power Supply

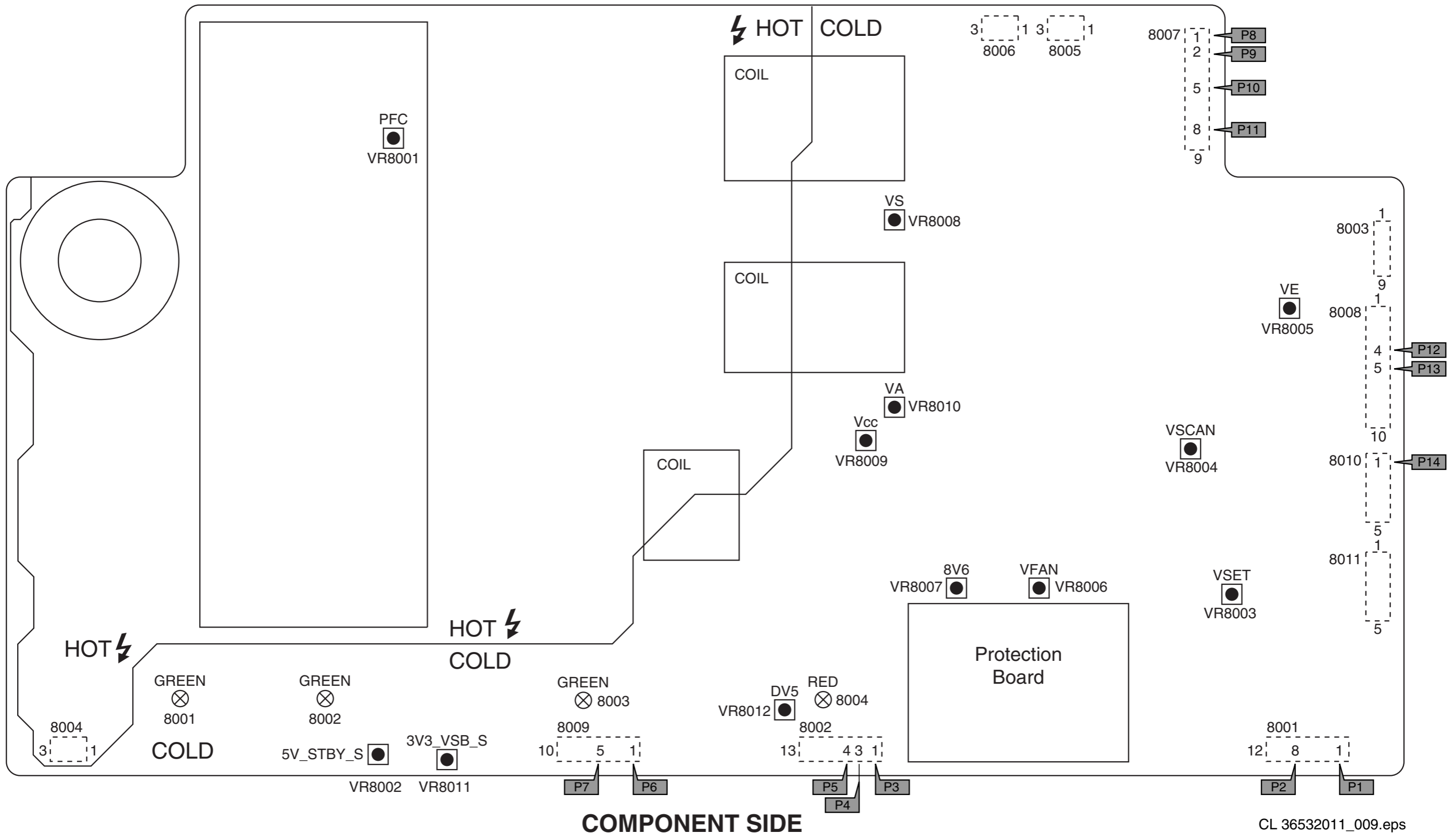

COMPONENT SIDE

Wiring Diagram

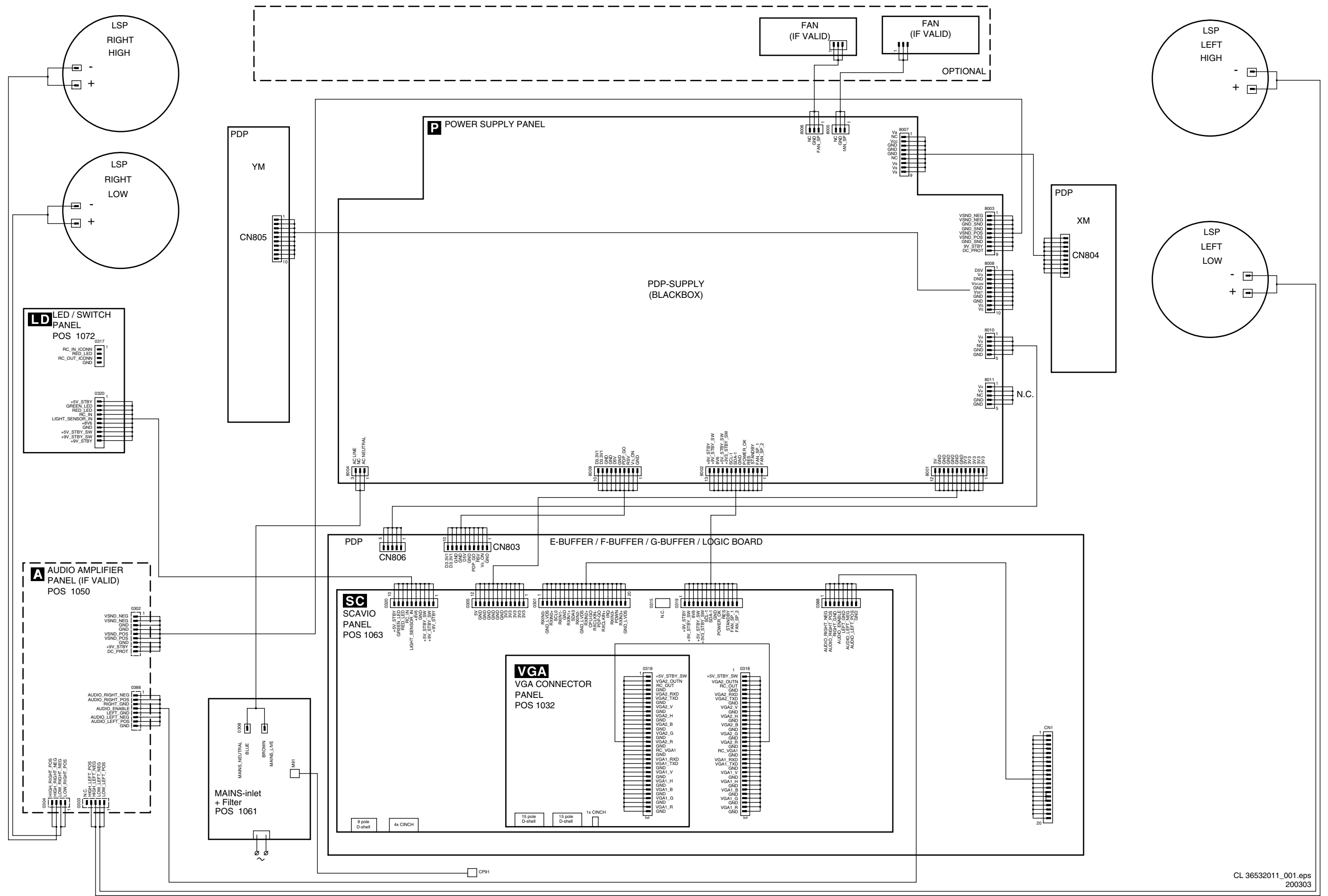

Audio Panel & Supply: DC Protection

A1 AUDIO PANEL & SUPPLY, DC PROTECTION

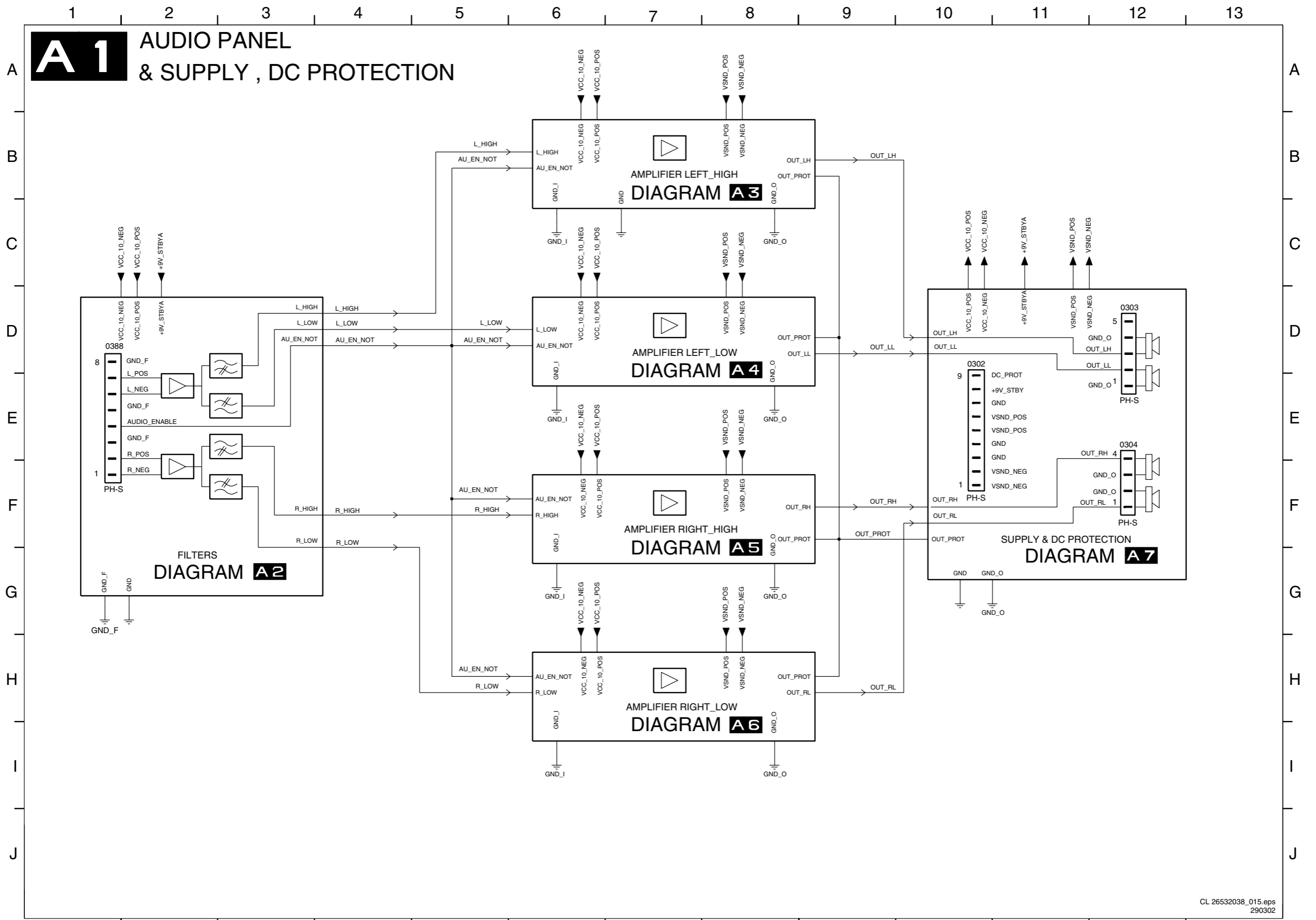

Audio Panel & Supply: Filters

A2

FILTERS

A
B
C
D
E
F

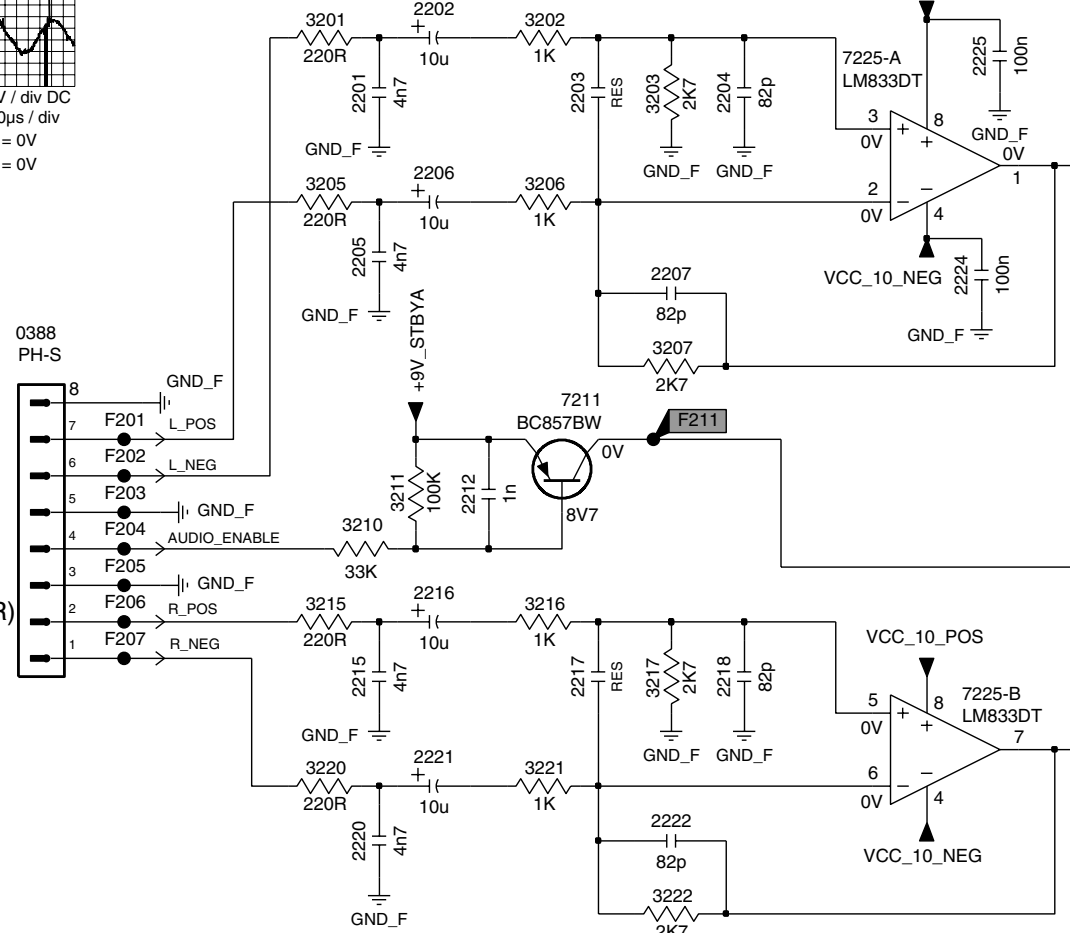
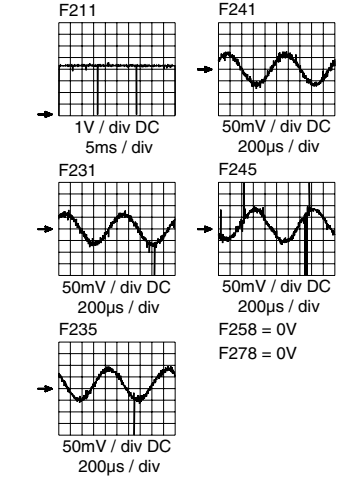

FROM 0388
SC14
SCAVIO PANEL
(AUDIO-PROCESSOR)

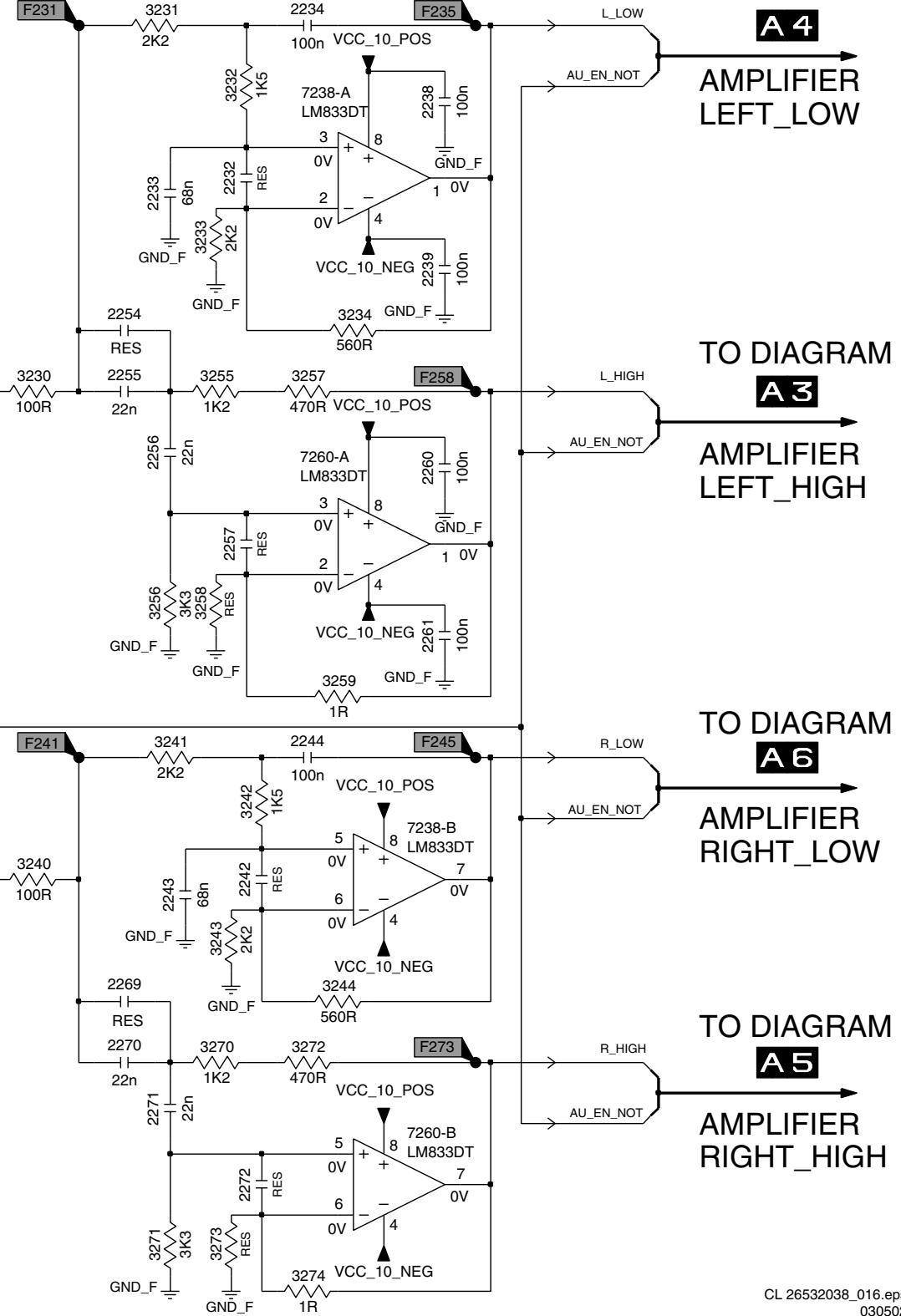
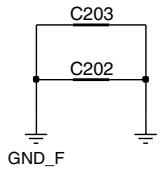

- 0388 C1
- 2201 B3
- 2202 B3
- 2203 B4
- 2204 B4
- 2205 C3
- 2206 B3
- 2207 C4
- 2212 D3
- 2215 D3
- 2216 D3
- 2217 D4
- 2218 D4
- 2220 E3
- 2221 E3
- 2222 E4
- 2224 C5
- 2225 B5
- 2232 A7
- 2233 A6
- 2234 A7
- 2238 A7
- 2239 B7
- 2242 E7
- 2243 E6
- 2244 D7
- 2254 B6
- 2255 B6
- 2256 C6
- 2257 C7
- 2260 C7
- 2261 C7
- 2269 E6
- 2270 E6
- 2272 F7
- 3201 B3
- 3202 B3
- 3203 B4
- 3205 B3
- 3206 B3
- 3207 C4
- 3210 D3
- 3211 D3
- 3215 D3
- 3216 D3
- 3217 D4
- 3220 E3
- 3221 E3
- 3222 E4
- 3230 B6
- 3231 A6
- 3232 A7
- 3233 B6
- 3234 B7
- 3240 E6
- 3241 D6
- 3242 D7
- 3243 E6
- 3244 E7
- 3255 B6
- 3256 C6
- 3257 B7
- 3258 C6
- 3259 D7
- 3270 E6
- 3271 F6
- 3272 E7
- 3273 F6
- 3274 F7
- 7211 C4
- 7225-A B5
- 7225-B D5
- 7238-A A7
- 7238-B D7
- 7260-A C7
- 7260-B F7
- C202 F2
- C203 F2
- F201 C2
- F202 C2
- F203 D2
- F204 D2
- F205 D2
- F206 D2
- F207 D2
- F211 C4
- F231 A6
- F235 A8
- F241 D6
- F245 D8
- F258 B8
- F273 E8

Audio Panel & Supply: Left High

2309 D4	2316 C5	2330 C7	2340 E7	2360 E8	3301 C3	3304 D2	3308 C4	3311 C4	3325 B5	3330 B6	3340 D6	3362 D8	5365 C9	6335 C7	6359 E7	7303 C3	7340 D7	7365-2 C8	F301 C3	F330 C7	F365 C8
2310 B3	2318 D5	2334 B8	2355 D7	2365 C9	3302 D3	3306 C3	3309 D4	3315 B5	3327 C5	3336 B8	3355 E6	5335 B8	6328 C6	6355 D6	6360 D7	7315 C4	7355 D6	C301 E3	F307 C4	F337 C8	
2315 C4	2319 D5	2335 B8	2359 E8	2366 C9	3303 C2	3307 C4	3310 B3	3318 D5	3328 B6	3337 C8	3361 E8	5360 E8	6334 B7	6356 E6	7302 D3	7330 C6	7365-1 D8	C302 E3	F328 B6	F362 D8	

1 2 3 4 5 6 7 8 9 10

A3

AUDIO AMPLIFIER LEFT HIGH

A
B
C
D
E

A
B
C
D
E

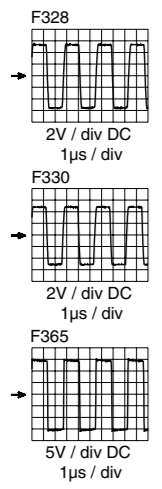

FROM DIAGRAM
A2
FILTERS

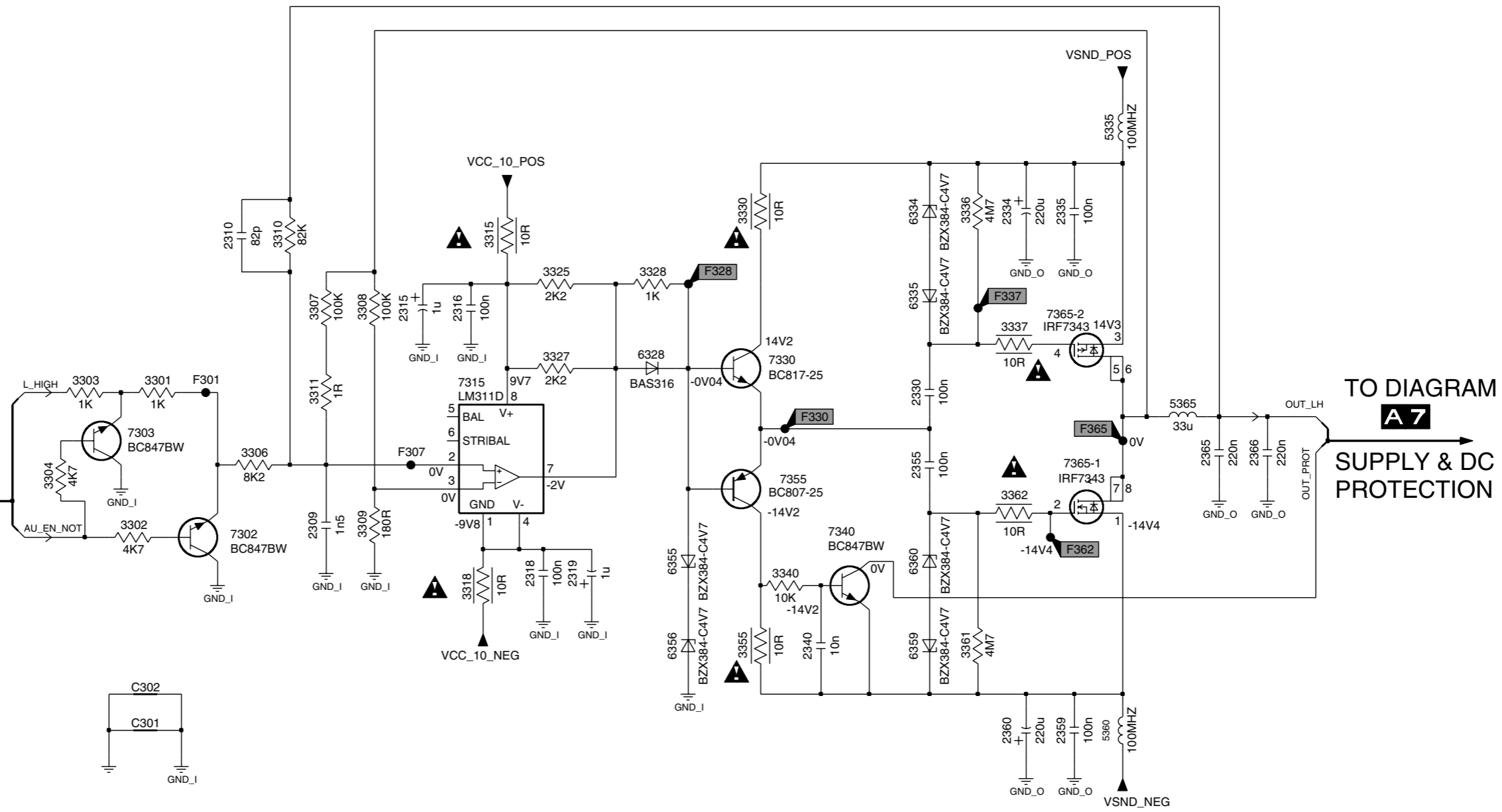

1 2 3 4 5 6 7 8 9 10

Audio Panel & Supply: Left Low

2409 D3	2416 C4	2430 C7	2440 E6	2460 E8	3401 C3	3404 D2	3408 C4	3411 C3	3425 B5	3430 B6	3440 D6	3462 D8	5465 C9	6435 C7	6459 E7	7403 C2	7440 D7	7465-2 C8	F428 B6	F462 D8
2410 B3	2418 D5	2434 B8	2455 D7	2465 D9	3402 D2	3406 C3	3409 D4	3415 B4	3427 C5	3436 B7	3455 E6	5435 B8	6428 C5	6455 D6	6460 D7	7415 C4	7455 D6	F401 C3	F430 C6	F465 C8
2415 C4	2419 D5	2435 B8	2459 E8	2466 D9	3403 C2	3407 C3	3410 B3	3418 D4	3428 B5	3437 C8	3461 E7	5460 E8	6434 B7	6456 E6	7402 D3	7430 C6	7465-1 D8	F407 D4	F437 C8	

A4 AUDIO AMPLIFIER LEFT LOW

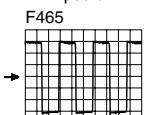
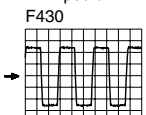
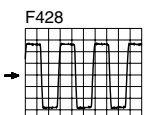

FROM DIAGRAM
A2
FILTERS

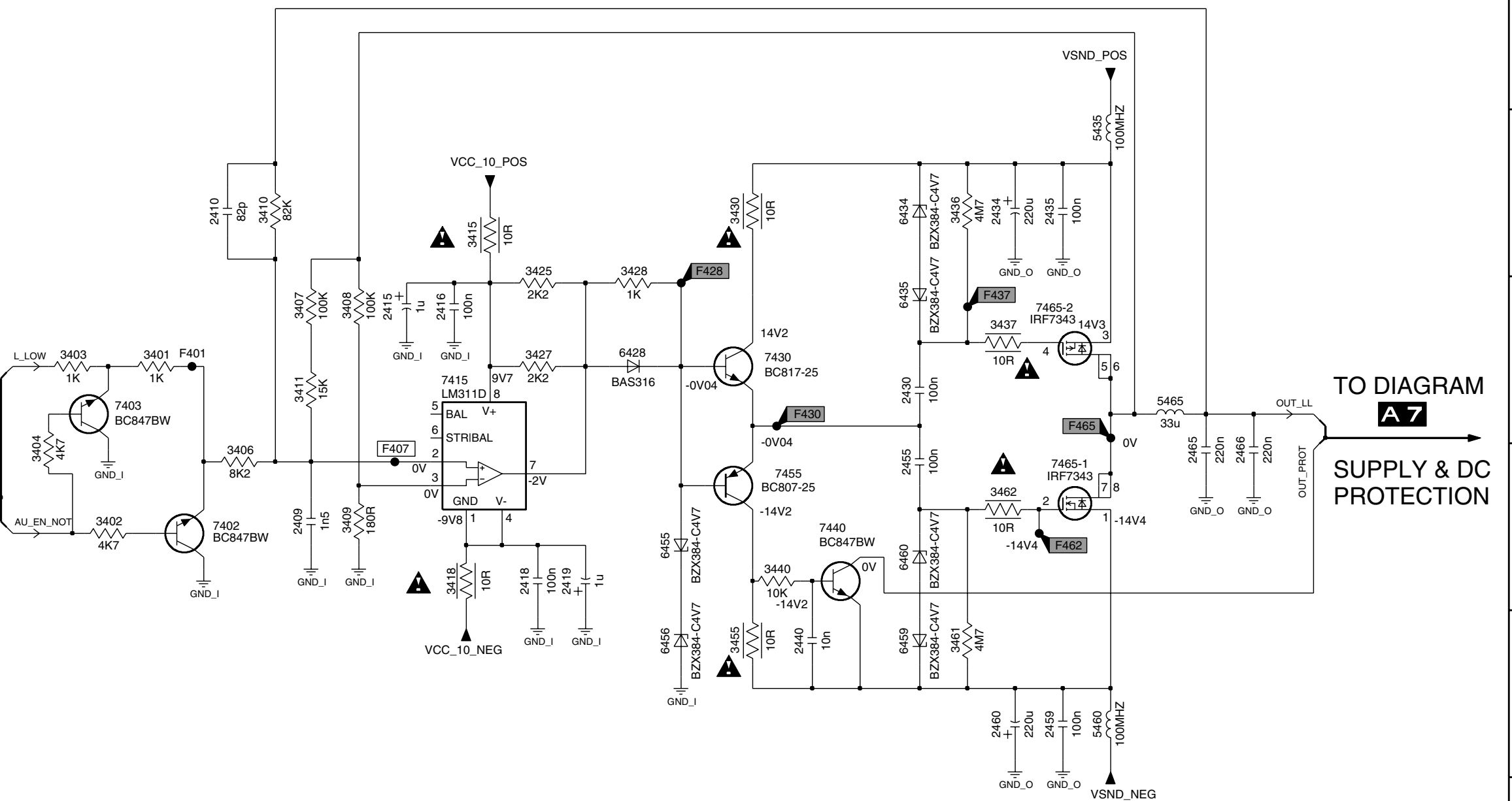

TO DIAGRAM
A7
SUPPLY & DC PROTECTION

Audio Panel & Supply: Right Low

2609 D4	2616 C4	2630 C7	2640 E7	2660 E8	3601 C3	3604 C2	3608 C4	3611 C4	3625 B5	3630 B6	3640 D6	3662 D8	5665 C9	6635 C7	6659 E7	7603 C2	7640 D7	7665-2 C8	F628 B6	F662 D8
2610 B3	2618 D5	2634 B8	2655 C7	2665 C9	3602 D2	3606 C3	3609 D4	3615 B5	3627 C5	3636 B8	3655 E6	5635 B8	6628 C6	6655 D6	6660 D7	7615 C4	7655 D6	F601 C3	F630 C7	F665 C8
2615 C4	2619 D5	2635 B8	2659 E8	2666 C9	3603 C2	3607 C4	3610 B3	3618 D4	3628 B6	3637 C8	3661 E8	5660 E8	6634 B7	6656 E6	7602 D3	7630 C6	7665-1 D8	F607 C4	F637 C8	

A6 AUDIO AMPLIFIER RIGHT LOW

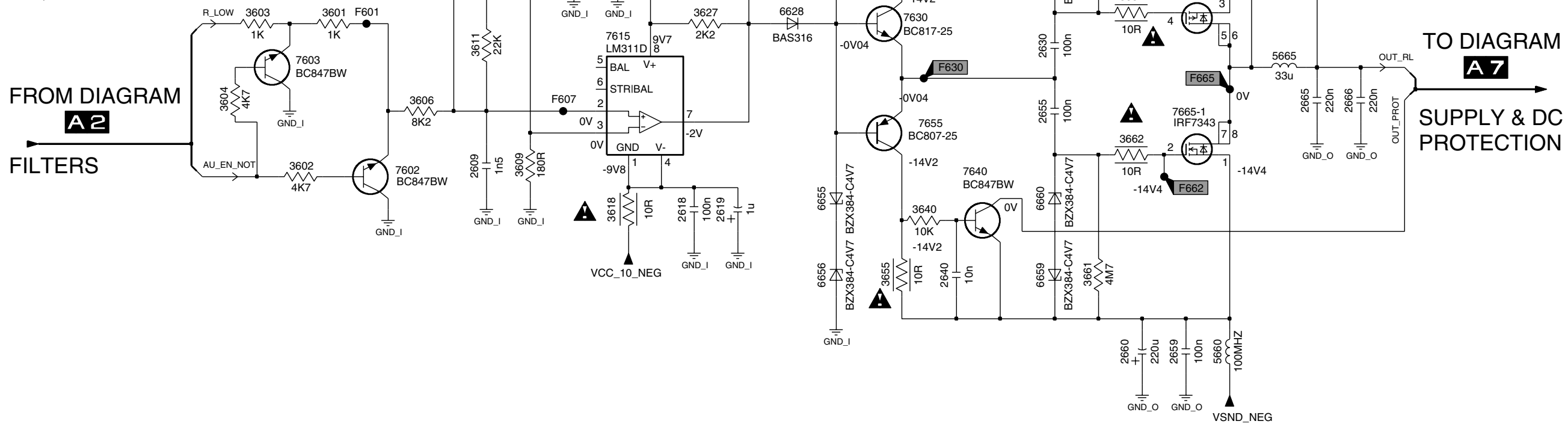
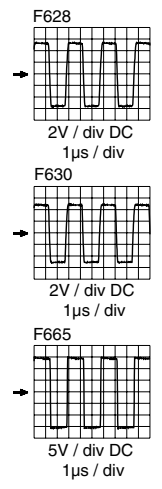

FROM DIAGRAM
A2
FILTERS

TO DIAGRAM
A7
SUPPLY & DC
PROTECTION

A7

SUPPLY & DC PROTECTION

DC PROTECTION

F730 = 14V4
 F735 = 9V
 F740 = -14V4
 F745 = -8V8

FROM DIAGRAM **A3** AUDIO AMPLIFIER LEFT HIGH
 FROM DIAGRAM **A4** AUDIO AMPLIFIER LEFT LOW
 FROM DIAGRAM **A5** AUDIO AMPLIFIER RIGHT HIGH
 FROM DIAGRAM **A6** AUDIO AMPLIFIER RIGHT LOW

SUPPLY

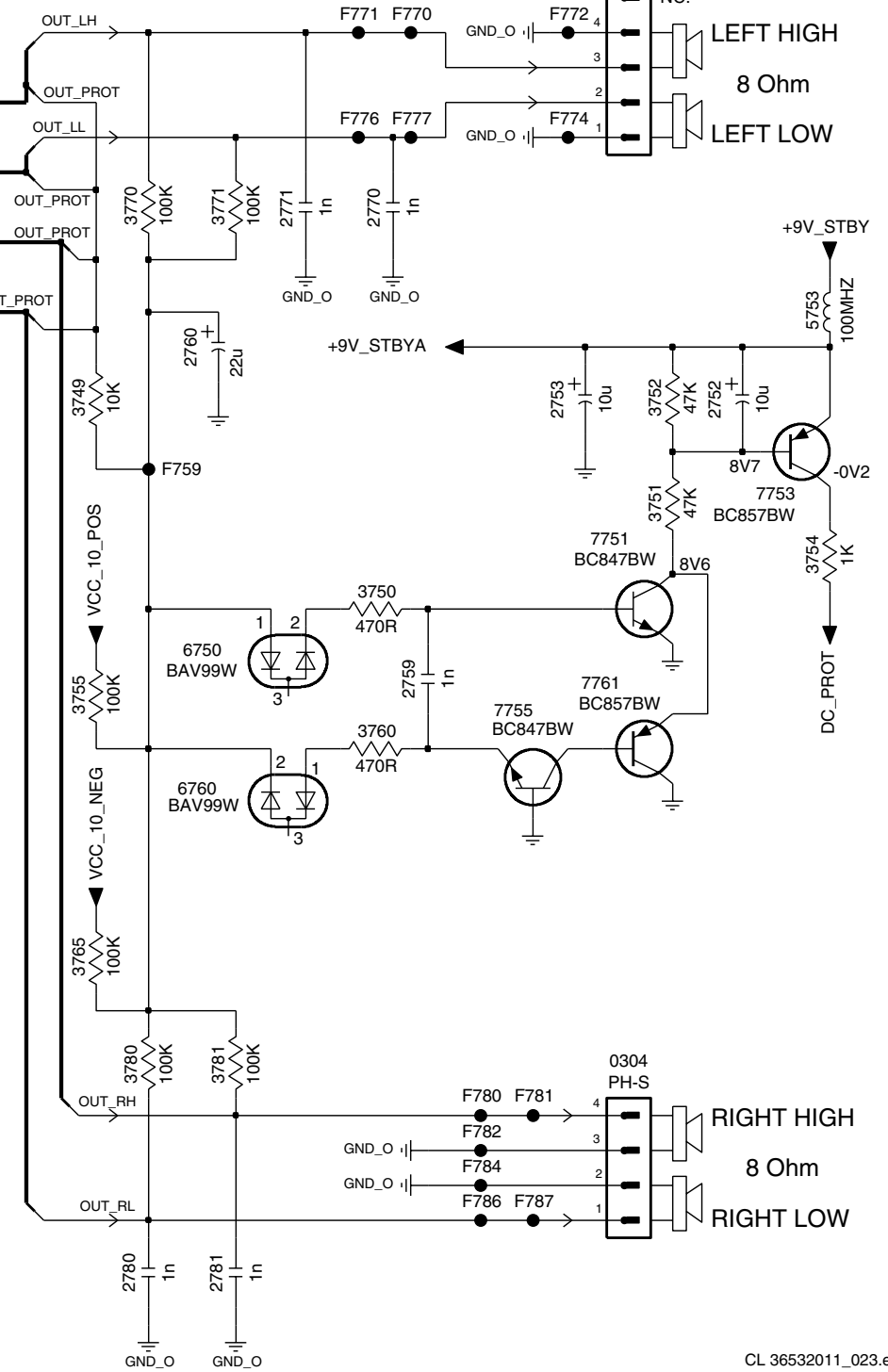
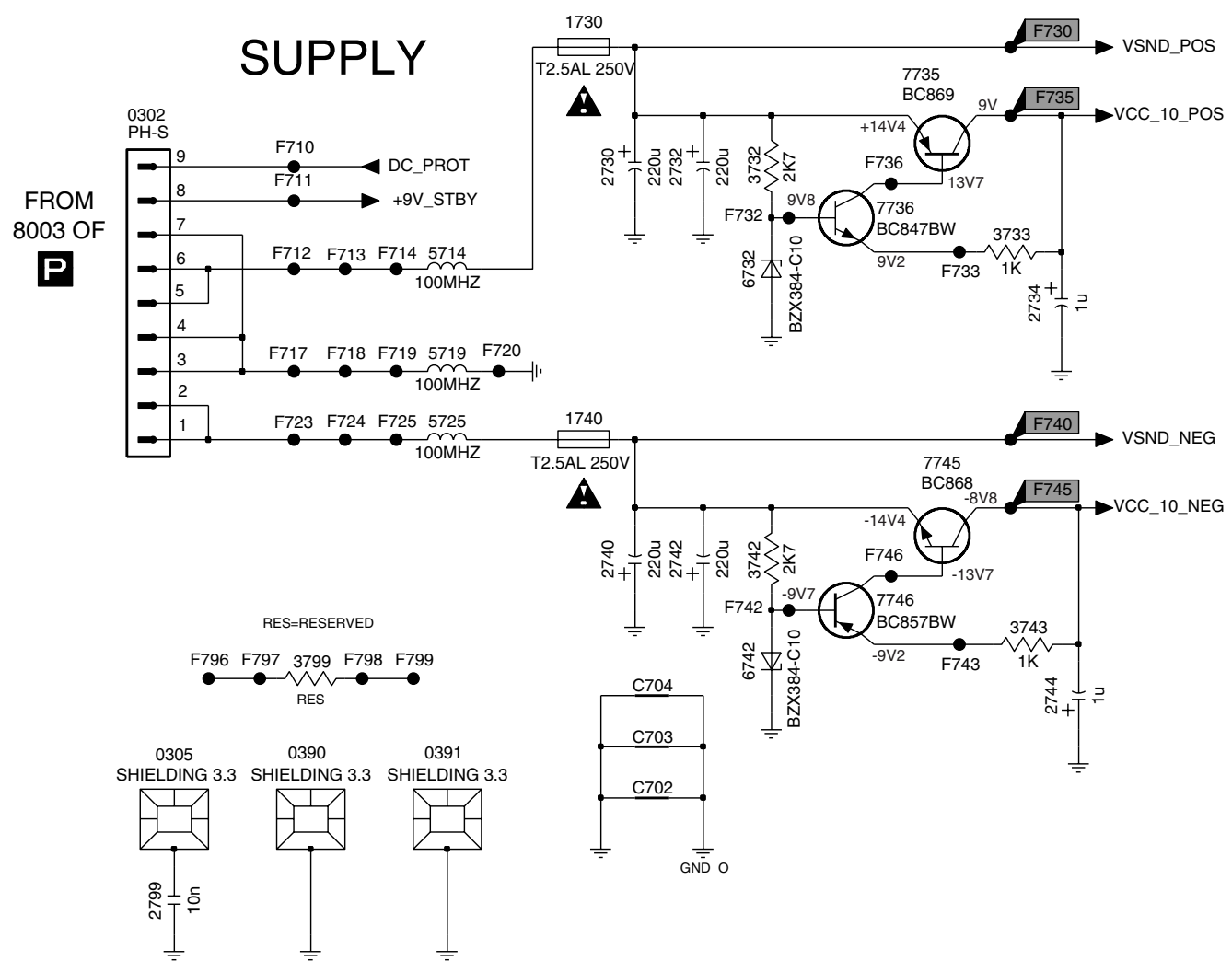

- 0302 C1
- 0303 A8
- 0304 E8
- 0305 E1
- 0390 E2
- 0391 E3
- 1730 B3
- 1740 D3
- 2730 C3
- 2732 C4
- 2734 D5
- 2740 E3
- 2742 E4
- 2744 E5
- 2752 C9
- 2753 C8
- 2759 D8
- 2760 B7
- 2770 B8
- 2771 B7
- 2780 F7
- 2781 F7
- 2789 F1
- 3732 C4
- 3733 C5
- 3742 E4
- 3743 E5
- 3749 C6
- 3750 C8
- 3751 C9
- 3752 C9
- 3754 C9
- 3755 D6
- 3760 D8
- 3765 E6
- 3770 B7
- 3771 B7
- 3780 E7
- 3781 E7
- 3799 E2
- 5714 C3
- 5719 D3
- 5725 D3
- 5753 B9
- 6732 C4
- 6742 E4
- 6750 D7
- 6760 D7
- 7735 C5
- 7736 C4
- 7745 D5
- 7746 E4
- 7751 C8
- 7753 C9
- 7755 D8
- 7761 D9
- C702 F3
- C703 E3
- C704 C3
- F710 C2
- F711 C2
- F712 C2
- F713 C2
- F714 C2
- F717 D2
- F718 D2
- F719 D2
- F720 D3
- F723 D2
- F725 D2
- F730 B5
- F732 C4
- F733 C5
- F735 C5
- F736 C4
- F740 D5
- F742 E4
- F743 E5
- F745 D5
- F746 E4
- F759 C7
- F770 A8
- F771 A8
- F772 A8
- F774 A8
- F776 A8
- F777 A8
- F780 E8
- F781 E8
- F782 F8
- F784 F8
- F786 F8
- F787 F8
- F788 E2
- F789 E2
- F799 E2

LED/Switch Panel



LED/SWITCH PANEL

A

B

C

D

E

F

A

B

C

D

E

F

FROM 0320
SC8

CONTROLE FUNCTIONS

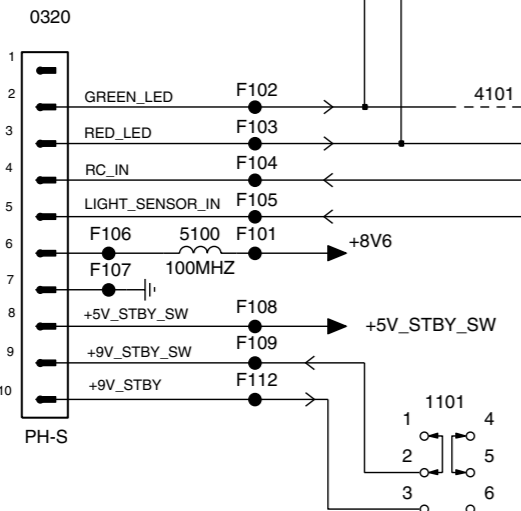

ON / OFF SWITCH

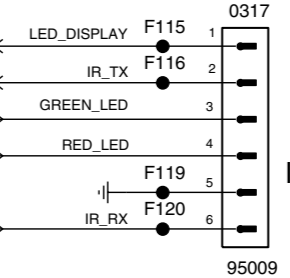
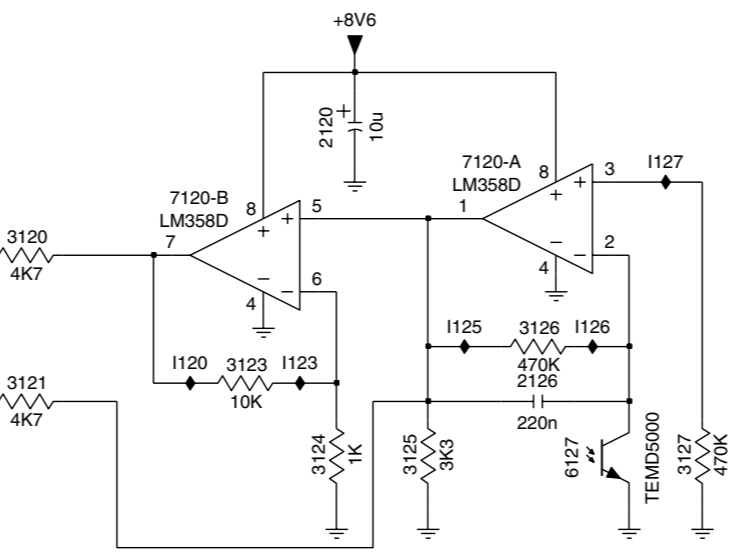
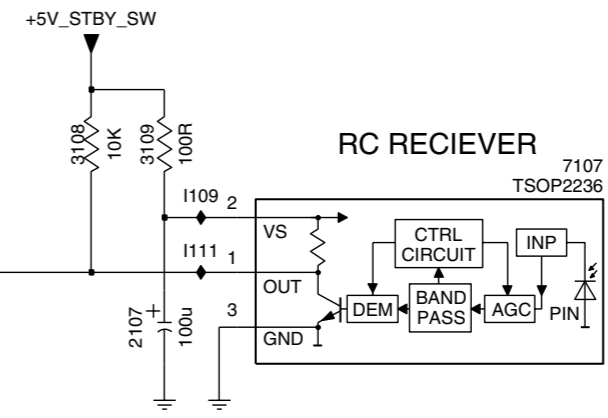
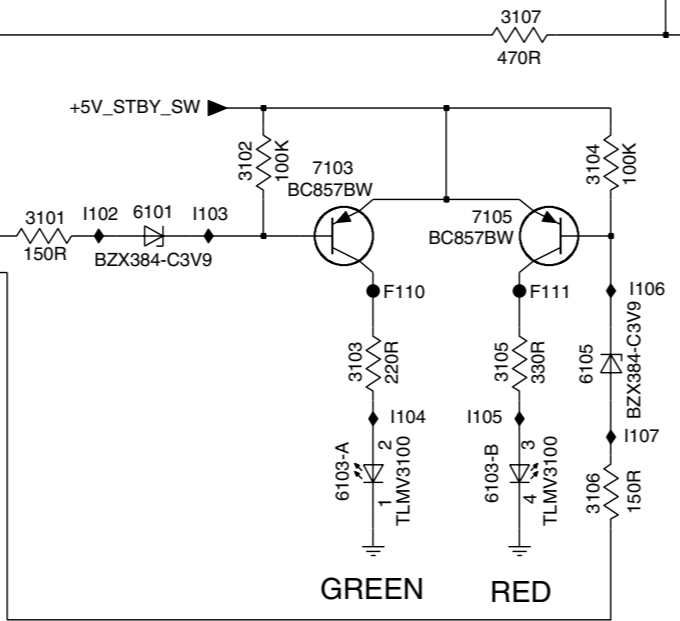
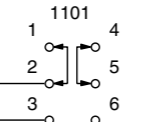

- 0317 A9
- 0320 B1
- 1101 D3
- 2107 C7
- 2120 E5
- 2126 F6
- 3100 C2
- 3101 C4
- 3102 B4
- 3103 C5
- 3104 B6
- 3105 C5
- 3106 D6
- 3107 B6
- 3108 B7
- 3109 B7
- 3120 E4
- 3121 F4
- 3122 F3
- 3123 F4
- 3124 F5
- 3125 F5
- 3126 F6
- 3127 F6
- 4101 C3
- 4107 B6
- 6101 C4
- 6103-A C5
- 6103-B D5
- 6105 C6
- 6127 F6
- 7103 B5
- 7105 B5
- 7107 C9
- 7120-A E6
- 7120-B E4
- F101 C2
- F102 C2
- F103 C2
- F104 C2
- F105 C2
- F106 C1
- F107 C1
- F108 C2
- F109 D2
- F110 C5
- F111 C6
- F112 D2
- F115 A9
- F116 A9
- F119 B9
- F120 B9
- I102 B4
- I103 B4
- I104 C5
- I105 C5
- I106 C6
- I107 C6
- I109 C7
- I111 C7
- I120 F4
- I123 F5
- I125 E5
- I126 E6
- I127 E6

SC1 SCAVIO PANEL (FUNCTION BLOCKS AND DIAGRAM CONNECTIONS)

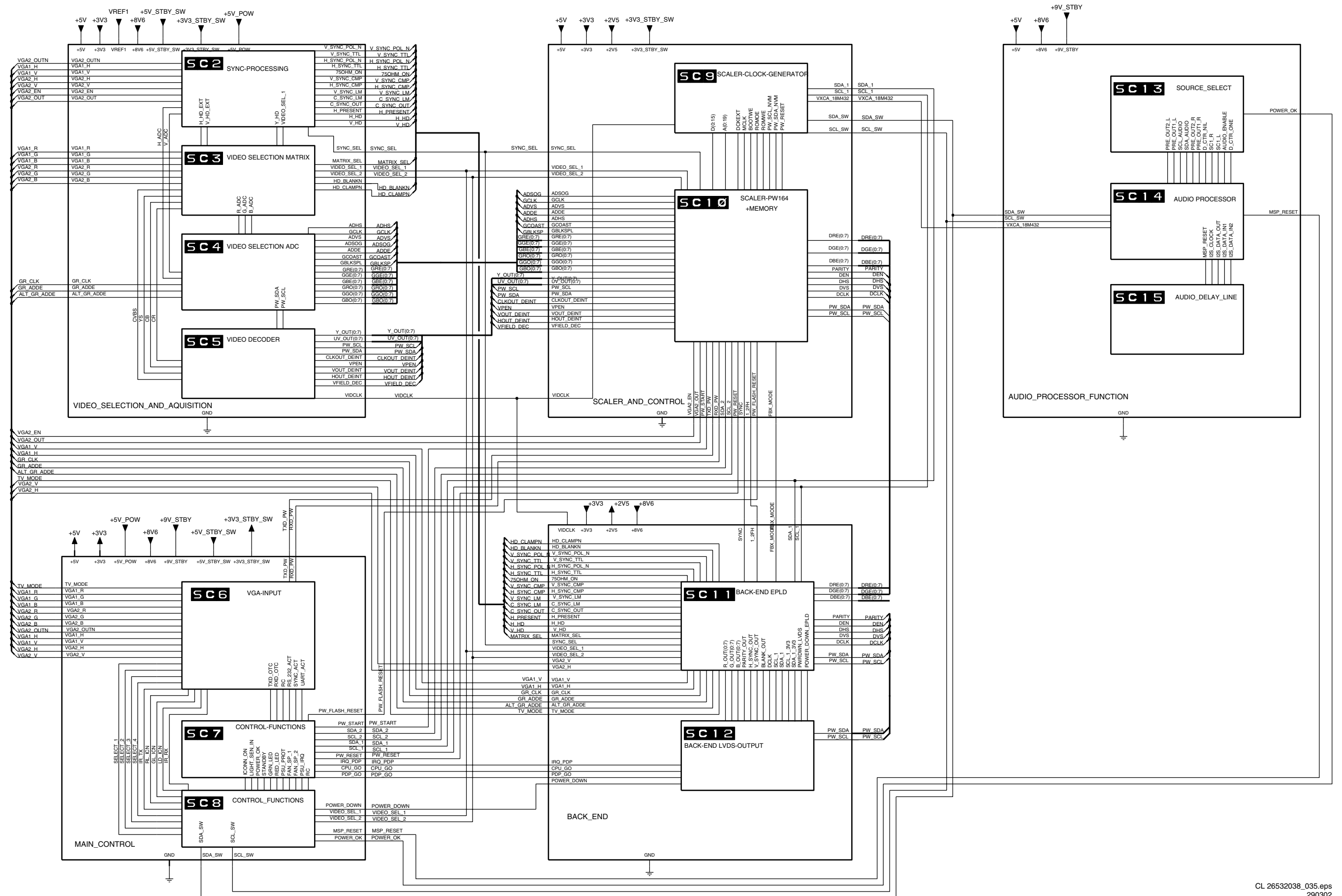

SCAVIO Panel: Sync Selection & Switching



SYNC SELECTION & SWITCHING
(ENHANCED ONLY, UNLESS INDICATED OTHERWISE)

SC6 10 11

TO SC3 4 6 8 10

A
B
C
D
E
F
G
H
I

A
B
C
D
E
F
G
H
I

SC3

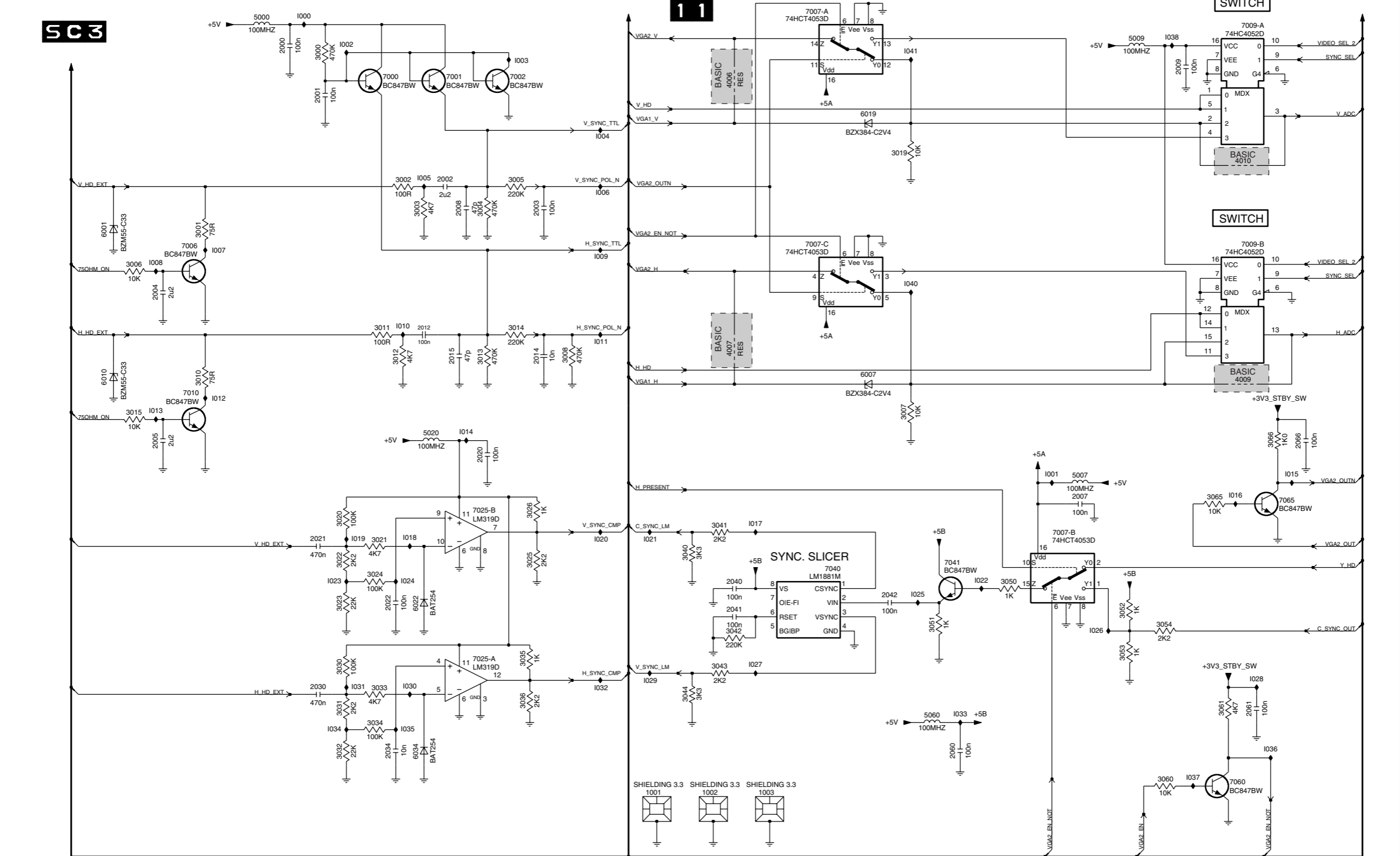

SCAVIO Panel: Video Selection & Matrix (Enhanced Only, Unless Indicated Otherwise)

SC3

VIDEO-SELECTION & MATRIX (ENHANCED ONLY, UNLESS INDICATED OTHERWISE)

0377 SPEAKERLESS VERSION

A

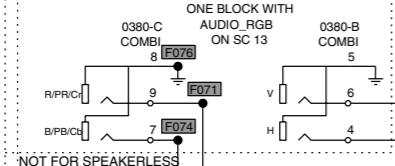
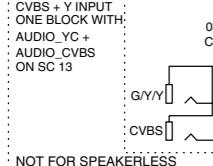

B

C

D

E

F

G

H

I

TO SC2

MATRIX

VIDEO-SELECTION

4 X SWITCH

TO SC5 6 11

TO SC4
SC8

0377 A2	3134 A6	7158-B I13
0379-A A2	3135 A7	7160 H11
0380-B A4	3136 A7	7165 A14
0380-C A3	3137 A8	F070 A2
2072 C3	3138 A9	F071 A3
2077 D3	3139 A9	F072 A5
2082 E3	3140 B10	F073 A2
2088 C6	2089 C7	3141 B11
2089 C7	3142 B11	F075 A5
2090 D6	3143 D10	F076 A3
2097 F6	3144 D10	3145 D10
2105 C10	3146 D11	F089 C7
2106 C9	3147 E10	F146 E14
2107 C9	3148 E10	F152 F14
2108 E8	3149 E11	F158 H14
2109 E7	3150 F10	I050 C4
2110 H7	3151 F10	I052 C3
2111 H8	3152 F11	I053 C4
2112 F2	3153 G10	I054 C6
2113 F3	3154 G10	I055 C5
2114 D6	3155 G11	I056 C5
2115 G3	3156 H10	I057 D3
2116 H2	3157 G10	I058 D6
2117 H3	3158 H11	I059 D2
2119 H3	3159 H10	I060 D3
2120 I2	3160 H10	I061 D5
2123 I3	3161 I11	I062 D3
2124 E6	3162 G13	I063 E5
2127 H6	3163 G13	I064 F5
2128 I6	3164 A13	I065 F6
2134 A6	3165 H13	I066 E3
2137 A9	3166 H13	I067 E2
2140 B10	3170 D9	I068 E3
2142 I0	3171 F9	I069 E3
2143 I0	3172 H9	I070 F5
2144 D10	3173 D9	I071 G5
2145 D12	3174 C10	I072 G6
2146 D14	3175 B9	I073 F2
2147 E10	3176 C9	I074 F2
2150 F10	3177 E7	I075 G5
2151 F14	3178 D7	I076 F3
2152 F14	3179 D7	I077 H5
2153 G10	3180 I7	I078 H6
2156 H10	3181 I8	I079 H5
2157 G12	3182 I9	I080 I5
2158 H14	3183 H8	I081 H2
2159 H10	3184 H8	I082 H2
2160 A12	3186 E9	I083 I6
2161 B12	3188 I11	I084 H3
2162 B12	3189 G11	I085 I5
2164 A13	3190 E11	I086 I2
2165 A13	3193 I3	I087 I2
2166 A13	3194 H3	I088 I3
2167 A14	3195 G3	I090 I7
2168 B14	4146 E13	I099 A13
3071 C2	4152 F13	I100 A13
3072 C2	4158 H13	I101 A14
3073 C3	5089 C7	I102 A6
3074 B3	5090 C7	I102 A6
3075 C4	5140 I10	I104 A7
3076 D2	5160 A12	I105 A8
3077 D2	5161 B12	I106 A9
3078 D3	5162 B12	I107 A10
3079 D3	5164 A13	I108 A12
3080 D4	5166 B14	I109 B10
3081 E2	5167 B14	I110 B11
3082 E2	5170 I11	I111 B11
3083 E3	5175 B10	I112 B14
3084 E3	5180 D8	I113 I10
3085 F4	6071 C2	I114 D10
3088 C5	6076 D2	I115 D11
3087 C5	6087 F2	I116 D11
3088 D5	6108 C9	I117 E10
3089 D6	6166 A14	I118 E10
3090 D5	7074 C3	I119 E11
3091 D5	7075 B4	I120 F10
3092 E5	7079 D3	I121 F11
3093 E6	7080 D4	I122 F11
3094 E5	7084 E3	I123 G10
3095 F5	7085 E4	I124 G10
3096 F5	7088-A C5	I125 G11
3097 F6	7088-B H5	I126 H10
3099 G5	7088-C F5	I127 H11
3100 G5	7089-A H7	I128 H11
3101 G5	7089-B F7	I129 H10
3102 G5	7089-C D7	I130 H11
3103 G6	7090-A D5	I131 I10
3104 H5	7090-B I5	I133 A13
3105 H5	7090-C G5	I134 B13
3106 I5	7100-A G8	I135 I2
3107 I6	7100-B E8	I136 I2
3108 I5	7100-C F8	I138 H8
3109 I5	7102 E7	I139 H6
3110 I5	7103 G7	I140 H7
3111 I6	7104 I8	I141 E7
3112 F1	7105 I8	I142 E7
3113 F2	7107 H9	I143 B7
3114 C5	7110 C7	I144 B10
3115 G2	7111 C8	I145 C8
3116 H1	7112 C8	I146 C10
3117 H2	7113 F2	I147 C9
3118 C6	7117 H2	I148 H8
3119 H2	7117 H2	I149 I8
3120 I1	7129 D13	I150 I8
3121 I2	7130 F13	
3122 D5	7131 G13	
3123 I3	7135 A7	
3124 D6	7138 A9	
3125 E5	7141 B11	
3126 F6	7145 D11	
3127 H5	7146-A C13	
3128 I6	7146-B E13	
3129 D13	7148 E10	
3130 F13	7151 F11	
3131 H13	7154 G10	
3132 E13	7157 G11	
3133 E14	7158-A G13	

SCAVIO Panel: Video Selection ADC

SC4

VIDEO-SELECTION -ADC (BASIC & ENHANCED VERSION)

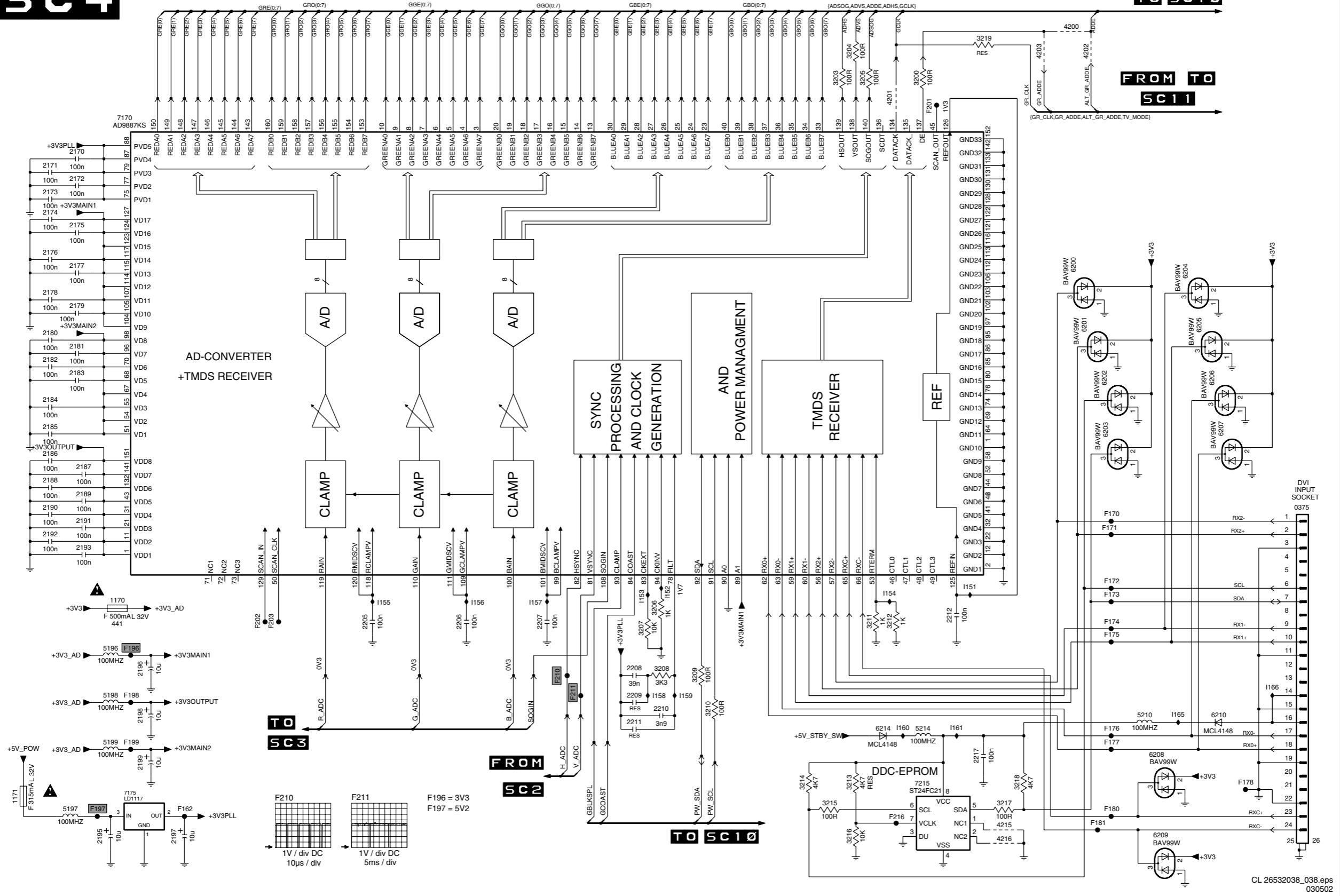

- 0375 F14
- 1170 G2
- 1171 H1
- 2170 B1
- 2171 B1
- 2172 B1
- 2173 B1
- 2174 C1
- 2175 C1
- 2176 C1
- 2177 C1
- 2178 D1
- 2179 D1
- 2180 D1
- 2181 D1
- 2182 D1
- 2183 D1
- 2184 E1
- 2185 E1
- 2186 E1
- 2187 E1
- 2188 F1
- 2189 F1
- 2190 F1
- 2191 F1
- 2192 F1
- 2193 F1
- 2195 I2
- 2196 G2
- 2197 I2
- 2198 H2
- 2199 H2
- 2205 G4
- 2206 G5
- 2207 G6
- 2208 H7
- 2209 H7
- 2210 H7
- 2211 H7
- 2212 G11
- 2217 H11
- 3200 A10
- 3203 A9
- 3204 A9
- 3205 A10
- 3206 G7
- 3207 G7
- 3208 H7
- 3209 H8
- 3210 H8
- 3211 G10
- 3212 G10
- 3213 I9
- 3214 I9
- 3215 I9
- 3216 I9
- 3217 I11
- 3218 I11
- 3219 A11
- 4200 A12
- 4201 A10
- 4202 A12
- 4203 A11
- 4215 I11
- 4216 I11
- 5196 G2
- 5197 I1
- 5198 H2
- 5199 H2
- 5210 H13
- 5214 H10
- 6200 C12
- 6201 D12
- 6202 D12
- 6203 E12
- 6204 C13
- 6205 D13
- 6206 D13
- 6207 E13
- 6208 H13
- 6209 I13
- 6210 H13
- 6214 H10
- 7170 B2
- 7175 I2
- 7215 I10
- F162 I2
- F170 F12
- F171 F12
- F172 G12
- F173 G12
- F174 G12
- F175 G12
- F176 H12
- F177 H12
- F178 I14
- F180 I12
- F181 I12
- F196 G2
- F197 I1
- F198 H2
- F199 H2
- F201 B10
- F202 G3
- F203 G3
- F210 H6
- F211 H7
- F216 I10
- I151 G11
- I152 G8
- I153 G7
- I154 G10
- I155 G5
- I156 G6
- I157 G6
- I158 H7
- I159 H8



VIDEO-SELECTION-DECODER (ENHANCED VERSION ONLY)

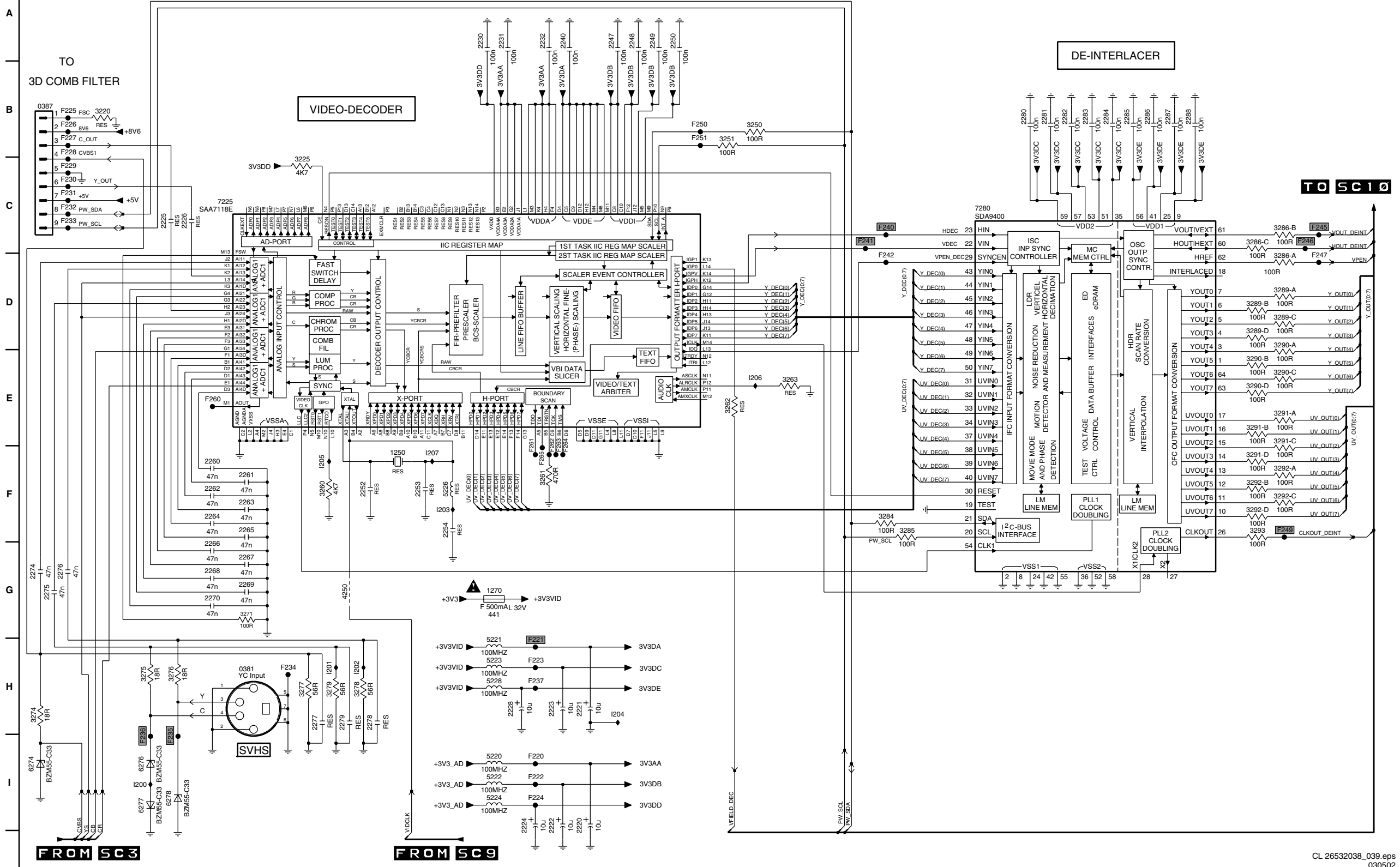

- 0381 H3
- 0387 B1
- 1250 F4
- 1270 G5
- 2220 I6
- 2221 H6
- 2222 I6
- 2223 H6
- 2224 I6
- 2225 C2
- 2226 C2
- 2228 H5
- 2230 A5
- 2231 A5
- 2232 A6
- 2240 A6
- 2247 A6
- 2248 A7
- 2249 A7
- 2250 A7
- 2252 F4
- 2253 F4
- 2254 F5
- 2260 F2
- 2261 F3
- 2262 F2
- 2263 F3
- 2264 F2
- 2265 F3
- 2266 G2
- 2267 G3
- 2268 G2
- 2269 G3
- 2270 G2
- 2271 G1
- 2272 G1
- 2273 H3
- 2274 H4
- 2275 H4
- 2280 B11
- 2281 B11
- 2282 B11
- 2283 B11
- 2284 B12
- 2285 B12
- 2286 B12
- 2287 B12
- 2288 B12
- 3220 B1
- 3225 C3
- 3250 B8
- 3251 B8
- 3260 F3
- 3262 E8
- 3263 E8
- 3271 G3
- 3272 H2
- 3273 H2
- 3274 H3
- 3275 H2
- 3276 H2
- 3277 H3
- 3278 H4
- 3279 H4
- 3284 F9
- 3285 F10
- 3286-A D13
- 3286-B C13
- 3286-C C13
- 3289-A D13
- 3289-B D13
- 3289-C D13
- 3290-A D13
- 3290-B E13
- 3290-C E13
- 3290-D E13
- 3291-A E13
- 3291-B E13
- 3291-C E13
- 3291-D F13
- 3292-A F13
- 3292-B F13
- 3292-C F13
- 3292-D F13
- 3293 F13
- 4250 G4
- 5220 I5
- 5221 H5
- 5222 I5
- 5223 H5
- 5224 I5
- 5225 F5
- 5228 H5
- 6274 I1
- 6275 I2
- 6276 I2
- 6277 I2
- 6278 I2
- 7225 C3
- 7280 C10
- F220 I6
- F221 H6
- F222 I6
- F223 H6
- F224 I6
- F225 B1
- F226 B1
- F227 B1
- F228 B1
- F229 C1
- F230 C1
- F231 C1
- F232 C1
- F233 C1
- F234 H3
- F235 I2
- F236 I2
- F237 H6
- F240 C9
- F241 C9
- F242 D9
- F243 C14
- F244 C14
- F245 C14
- F246 C14
- F247 D14
- F248 F13
- F249 B7
- F251 B7
- F260 E2
- F261 E6
- F262 E6
- F263 E6
- F264 E6
- F265 E6
- I200 I2
- I201 H4
- I202 H4
- I203 F5
- I204 H7
- I205 F3
- I206 E8
- I207 F5

SCAVIO Panel: VGA Input

SC6 VGA INPUT (BASIC & ENHANCED VERSION)

A
B
C
D
E
F
G
H
I
J

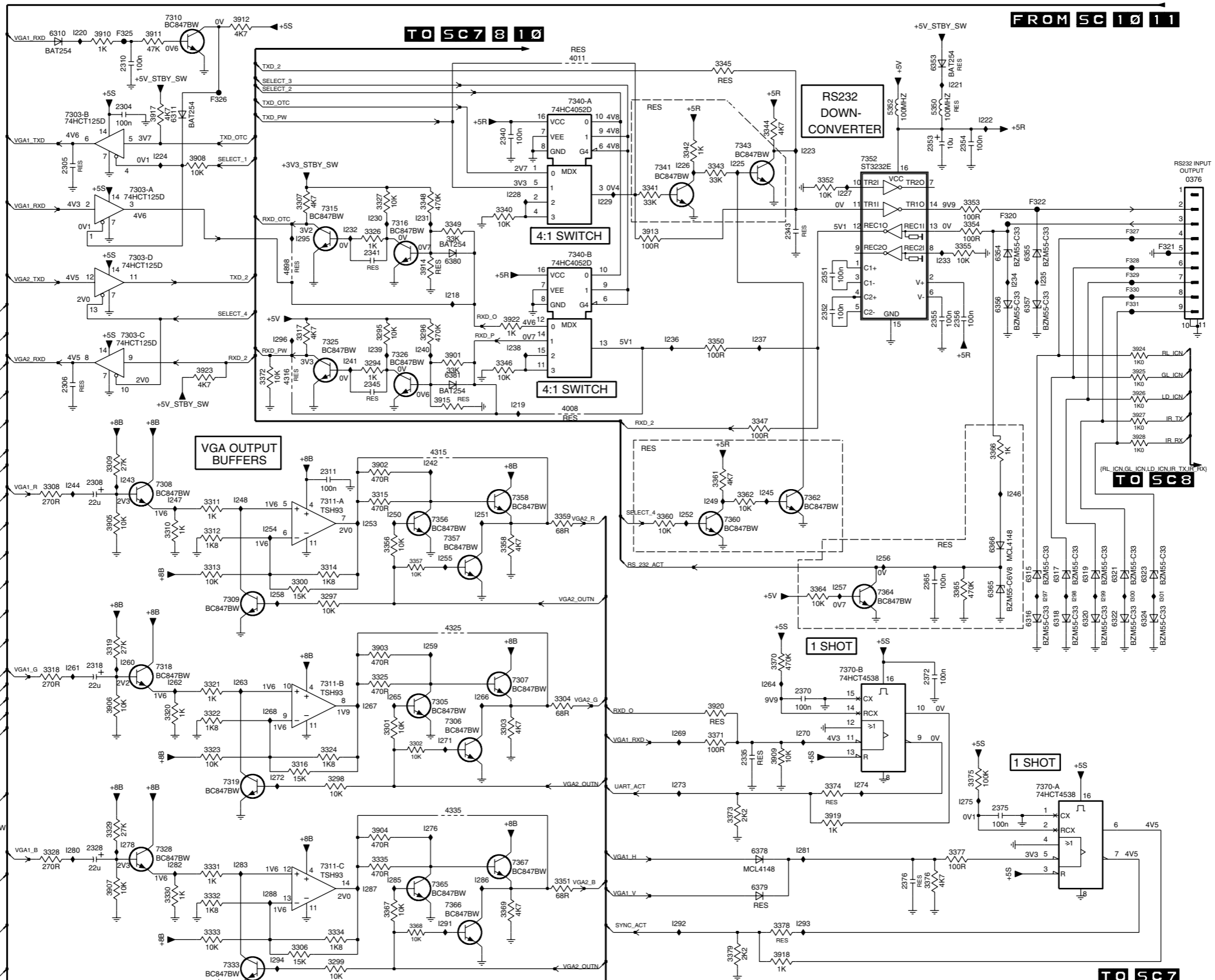
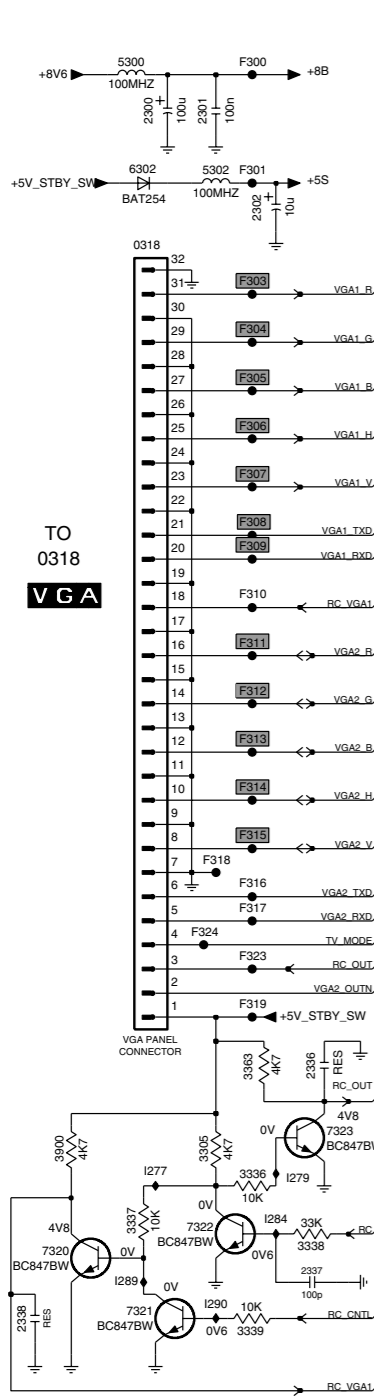

FROM SC 10 11

TO SC 7 8 10

TO SC 7

- 0318 C1
- 0376 B14
- 2300 B1
- 2301 B2
- 2302 B2
- 2304 B4
- 2305 B3
- 2306 D3
- 2308 E3
- 2310 A4
- 2311 A6
- 2318 G3
- 2328 I3
- 2335 H10
- 2338 H2
- 2337 I2
- 2338 J1
- 2340 B8
- 2341 C6
- 2343 C10
- 2345 D6
- 2351 C11
- 2352 D11
- 2353 B12
- 2354 B12
- 2355 D12
- 2356 D12
- 2365 F12
- 2370 G10
- 2372 G12
- 2375 H12
- 2376 I11
- 3294 D6
- 3295 D6
- 3296 D7
- 3297 F6
- 3298 H6
- 3299 J6
- 3300 F5
- 3301 H6
- 3302 H7
- 3303 H8
- 3304 G8
- 3305 I2
- 3306 J5
- 3307 C6
- 3308 E3
- 3309 E4
- 3310 F4
- 3311 E5
- 3312 F5
- 3313 F5
- 3314 F6
- 3315 E6
- 3316 H5
- 3317 D6
- 3318 G3
- 3319 G4
- 3320 H4
- 3321 G5
- 3322 H5
- 3323 H5
- 3324 H6
- 3325 C6
- 3326 C6
- 3327 C6
- 3328 I3
- 3329 I4
- 3330 I4
- 3331 I5
- 3332 I5
- 3333 J5
- 3334 J6
- 3335 I6
- 3336 I2
- 3337 I1
- 3338 I2
- 3339 J2
- 3340 C7
- 3341 B9
- 3342 B9
- 3343 B10
- 3344 B10
- 3345 A10
- 3346 D7
- 3347 E10
- 3348 C7
- 3349 C7
- 3350 D10
- 3351 I8
- 3352 B11
- 3353 C12
- 3354 C12
- 3355 C12
- 3356 F6
- 3357 F7
- 3358 F8
- 3359 F8
- 3360 F9
- 3361 E10
- 3362 E10
- 3363 H2
- 3364 F11
- 3365 F12
- 3366 E12
- 3367 I6
- 3368 J7
- 3369 I8
- 3370 G10
- 3371 H10
- 3372 D5
- 3373 H10
- 3374 H11
- 3375 H12
- 3376 I2
- 3377 I2
- 3378 J10
- 3379 J10
- 3900 I1
- 3901 D7
- 3902 E6
- 3903 G6
- 3904 B2
- 3905 F4
- 3906 G4
- 3907 I4
- 3908 B4
- 3909 H10
- 3910 A4
- 3911 A4
- 3912 A5
- 3913 C9
- 3914 C7
- 3915 D7
- 3917 B4
- 3918 J10
- 3919 I11
- 3920 G10
- 3922 D8
- 3923 D5
- 3924 D4
- 3925 B10
- 3926 D7
- 3927 E14
- 3928 E14
- 3929 E8
- 3930 E8
- 3931 D7
- 3932 H2
- 3933 C14
- 3934 C12
- 3935 C14
- 3936 C12
- 3937 B7
- 3938 J10
- 3939 I11
- 3940 A3
- 3941 D7
- 3942 E7
- 3943 E3
- 3944 E3
- 3945 A3
- 3946 E3
- 3947 E3
- 3948 E3
- 3949 E3
- 3950 E3
- 3951 E3
- 3952 E3
- 3953 E3
- 3954 E3
- 3955 E3
- 3956 E3
- 3957 E3
- 3958 E3
- 3959 E3
- 3960 E3
- 3961 E3
- 3962 E3
- 3963 E3
- 3964 E3
- 3965 E3
- 3966 E3
- 3967 E3
- 3968 E3
- 3969 E3
- 3970 E3
- 3971 E3
- 3972 E3
- 3973 E3
- 3974 E3
- 3975 E3
- 3976 E3
- 3977 E3
- 3978 E3
- 3979 E3
- 3980 E3
- 3981 E3
- 3982 E3
- 3983 E3
- 3984 E3
- 3985 E3
- 3986 E3
- 3987 E3
- 3988 E3
- 3989 E3
- 3990 E3

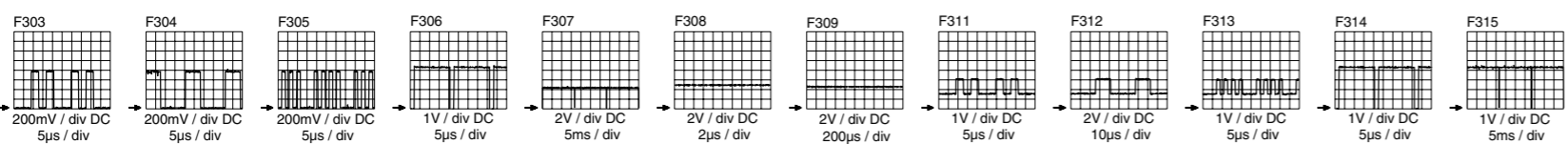

SCAVIO Panel: Control Functions 1

(BASIC & ENHANCED VERSION)

CONTROL FUNCTIONS 1

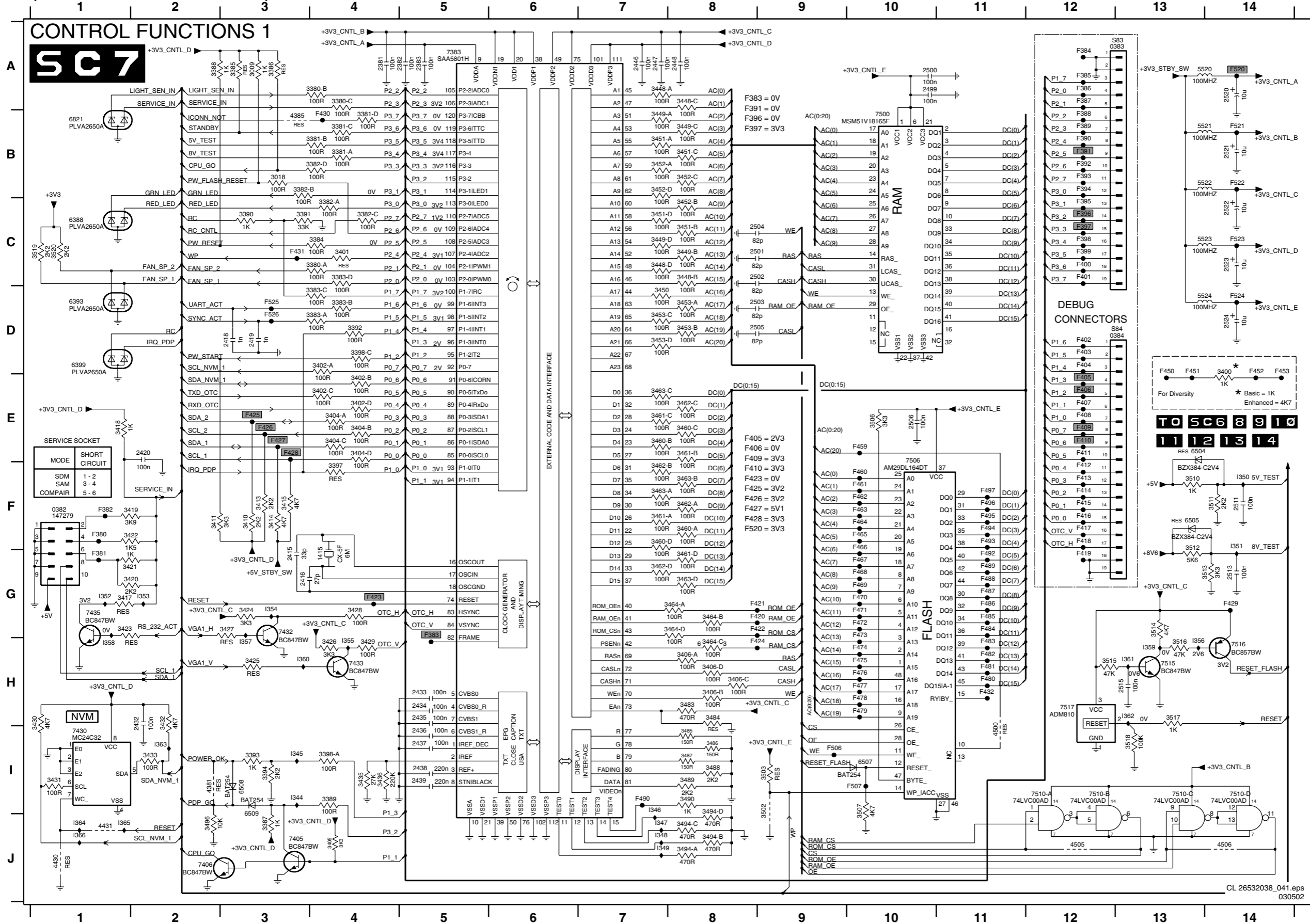

0382 F1	3452-D B7	F415 F12
0383 A12	3453-A D8	F416 F12
0384 D12	3453-B D8	F417 F12
1415 G4	3453-C D7	F418 F12
2381 A4	3453-D D7	F419 G12
2382 A5	3460-A F8	F420 G9
2383 A5	3460-B E7	F421 G9
2415 G3	3460-C E8	F422 G9
2416 G3	3461-A F7	F423 G4
2418 D3	3461-B E8	F424 H9
2419 D3	3461-C E7	F425 E3
2420 E2	3461-D E8	F426 E3
2432 H6	3462-A F8	F427 E3
2433 H5	3462-B F7	F428 G9
2434 H5	3462-C E8	F429 G14
2435 H5	3462-D E8	F430 B4
2436 I5	3462-E G7	F431 C3
2437 I5	3463-A F7	F432 H11
2438 I5	3463-B E8	F433 C3
2439 I5	3463-C E7	F434 H11
2446 A7	3463-D G8	F435 D14
2447 A7	3464-A G8	F436 D14
2448 A8	3464-B G8	F437 G10
2499 A10	3464-C H8	F438 F10
2500 A10	3464-D G8	F439 F10
2501 C8	3465-B F8	F440 F10
2502 C8	3465-C E7	F441 F10
2503 D6	3465-D E8	F442 F10
2504 C8	3466-A H8	F443 F10
2505 D8	3466-B H8	F444 F10
2506 E10	3466-C H8	F445 F10
2511 F14	3466-D H8	F446 G10
2513 G14	3467-A H8	F447 H10
2515 H13	3467-B H8	F448 G10
2520 A14	3467-C H8	F449 H10
2521 A14	3467-D H8	F450 H10
2522 C14	3467-E H8	F451 F10
2523 C14	3467-F H8	F452 F10
2524 D14	3467-G H8	F453 F10
3009 A3	3467-H H8	F454 F10
3018 B3	3506 E10	F455 F10
3380-A C4	3507 F10	F456 F10
3380-B A4	3508 F10	F457 F10
3380-C A4	3511 F14	F458 H11
3381-A B4	3512 F13	F459 H11
3381-B B4	3513 G14	F460 H11
3381-C B4	3514 G13	F461 H11
3381-D B4	3515 H12	F462 G11
3382-A C4	3516 H13	F463 G11
3382-B B3	3517 H13	F464 G11
3382-C A4	3518 I13	F465 G11
3382-D B4	3519 C1	F466 G11
3383-A D4	3520 C1	F467 G11
3383-B D4	4381 B1	F468 G11
3383-C D4	4385 B3	F469 G11
3383-D C4	4393 J1	F470 G11
3384 C4	4500 I11	F471 G11
3385 A3	4501 J12	F472 G11
3386 A3	4505 J12	F473 G11
3387 J2	4506 J14	F474 G11
3388 A2	4520 A13	F475 G11
3389 I4	4521 B13	F476 G11
3390 C3	4522 B13	F477 G11
3391 C3	4523 B13	F478 G11
3392 C3	4524 B14	F479 G11
3393 I3	6388 C1	F480 G11
3394 I3	6393 D1	F481 G11
3397 F4	6399 D1	F482 G11
3398-A D4	6504 I13	F483 G11
3398-B D4	6505 F13	F484 G11
3400 D14	6507 J10	F485 G11
3401 C4	6508 J10	F486 G11
3402-A D4	6509 J3	F487 G11
3402-B E4	6821 B1	F488 G11
3402-C E4	7383 A5	F489 G11
3402-D E4	7405 J3	F490 G11
3404-A E4	7406 J2	F491 G11
3404-B E4	7430 H1	F492 G11
3404-C E4	7432 G3	F493 G11
3404-D E4	7433 H4	F494 G11
3405 H4	7435 G1	F495 G11
3406-A H8	7500 B10	F496 F11
3406-B H8	7506 F10	F497 F11
3406-C H8	7510-A I12	F498 F11
3406-D H8	7510-B I12	F499 F11
3410 F3	7510-C I13	F500 F11
3411 F2	7510-D I14	F501 F11
3412 F3	7515 H13	F502 F11
3413 F3	7516 H14	F503 F11
3414 F3	7517 H12	F504 F11
3415 F3	7518 F11	F505 F11
3417 G1	7519 H1	F506 F11
3418 E1	7520 H1	F507 F11
3419 F2	7521 H1	F508 F11
3420 G2	7522 H1	F509 F11
3421 G1	7523 H1	F510 F11
3422 F2	7524 H1	F511 F11
3423 G1	7525 H1	F512 F11
3424 G3	7526 H1	F513 F11
3425 H3	7527 H1	F514 F11
3426 H4	7528 H1	F515 F11
3427 G3	7529 H1	F516 F11
3428 G4	7530 H1	F517 F11
3429 H4	7531 H1	F518 F11
3430 H1	7532 H1	F519 F11
3431 I1	7533 H1	F520 F11
3432 H2	7534 H1	F521 F11
3433 I2	7535 H1	F522 F11
3434 I4	7536 H1	F523 F11
3436 I4	7537 H1	F524 F11
3448-A A7	7538 H1	F525 F11
3448-B C8	7539 H1	F526 F11
3448-C A8	7540 C12	F527 F11
3448-D B7	7541 D12	F528 F11
3449-A B7	7542 D12	F529 F11
3449-B C8	7543 D12	F530 F11
3449-C B8	7544 E12	F531 F11
3449-D C7	7545 E12	F532 F11
3450 D7	7546 E12	F533 F11
3451-A B7	7547 E12	F534 F11
3451-B C8	7548 E12	F535 F11
3451-C B8	7549 E12	F536 F11
3451-D C7	7550 E12	F537 F11
3452-A B7	7551 F12	F538 F11
3452-B C8	7552 F12	F539 F11
3452-C B8	7553 F12	F540 F11
	7554 F12	F541 F11

SCAVIO Panel: Control Functions 2

SC8 CONTROL FUNCTIONS 2 (BASIC & ENHANCED VERSION)

A
B
C
D
E
F
G
H
I

0305 C2
0315 H5
0316 I5
0319 E2
0320 B2
1100 C3
1105 F3
2530 C8
2531 C6
2533 G5
2534 G6
2535 F5
2537 D2
2538 D3
2541 C9
2546 C3
2547 C3
2548 C3
2550 A3
2551 A3
2552 A3
2553 A4
2554 H10
2555 F10
2557 H4
2558 G4
2559 H3
2560 G3
2562 H2
2563 H2
2564 H2
2565 I2
2566 I2
3530 C7
3531 E7
3532 E7
3533 G5
3534 G6
3535 F5
3536 F4
3537 H5
3538 G5
3539 H5
3540 B9
3541 B9
3542 B12
3543 A12
3544 B13
3545 G3
3546 C13
3547 C13
3548 D14
3549 I5
3550 B3
3551 B3
3552 B3
3553 B3
3554 G5
3555 G6
3556 E9
3557 G3
3558 G3
3559 G3
3560 G3
3561 C13
3562 D13
3563 C13
3564 B14
3565 C14
3566 C13
3567 C13
3568 D7
3569 E7
3570 F9
3572 E7
3573 D7
5530 C5
5541 C9
6551 H13
6552 H13
6553 C13
6554 F13
6555 E13
7530 D6
7540 A10
7550-A I12
7550-B H10
7555-B F10
7555-C G12
7563 D14
F527 C12
F528 B12
F529 D2
F530 B2
F531 B2
F532 B2
F533 B2
F534 B2
F535 C2
F536 C2
F537 C2
F538 C2
F539 C2
F540 C2
F541 E2
F542 E2
F543 E2
F544 E2
F545 F2
F546 F2
F547 F2
F548 F2
F549 F2
F550 F2
F551 F2
F552 F2

F540 = 5V
F541 = 3V3
F546 = 9V
F547 = 9V
F549 = 5V
F550 = 3V3

TO 0320
LD
LED-PANEL DISPLAY

TO 8001
P
POWER SUPPLY

TO 8002
P
POWER SUPPLY

EXTERNAL ADC

I/O EXPANDER

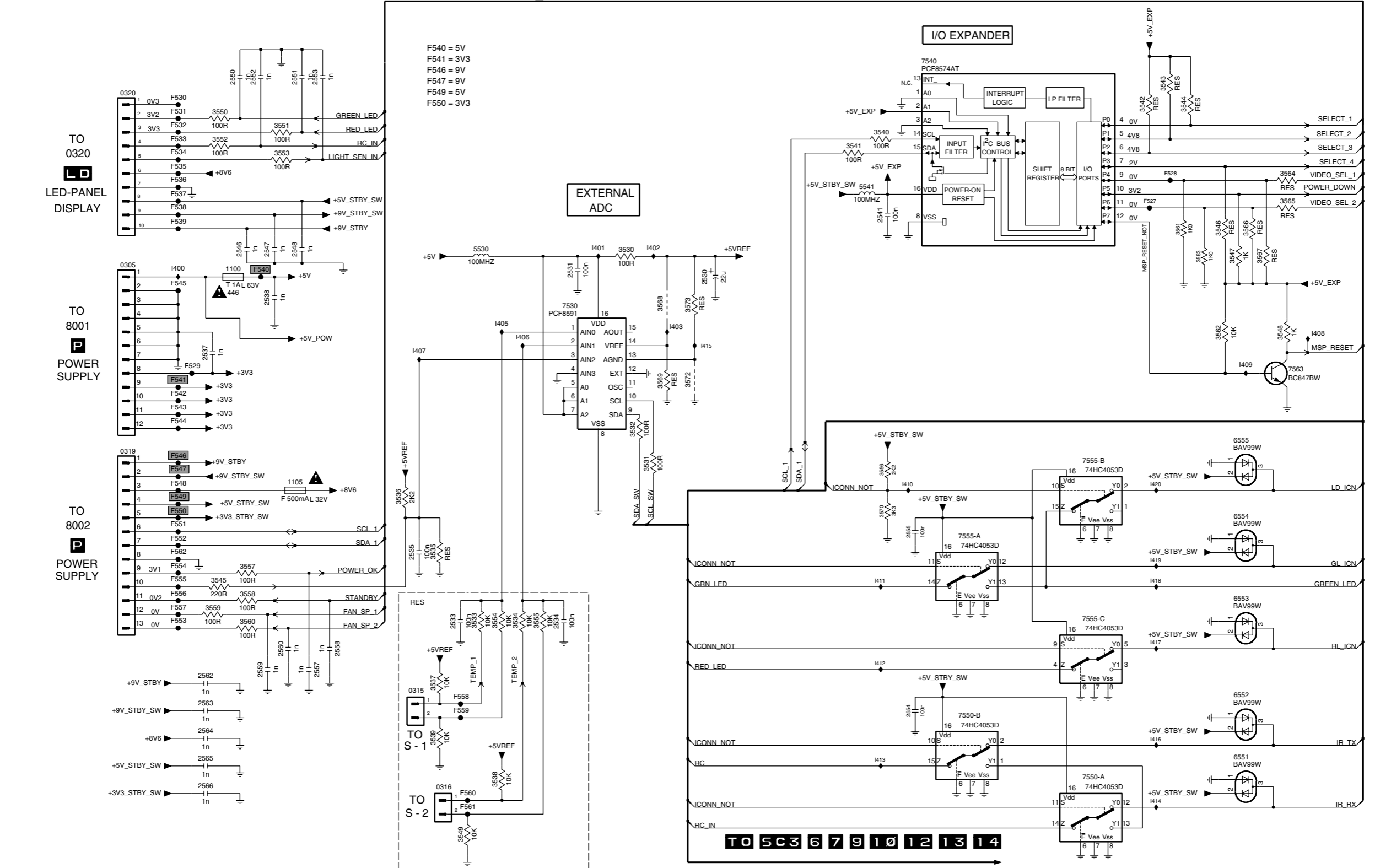

TO SC3 6 7 9 10 12 13 14



SCALER-CLOCK-GENERATOR (BASIC & ENHANCED VERSION)

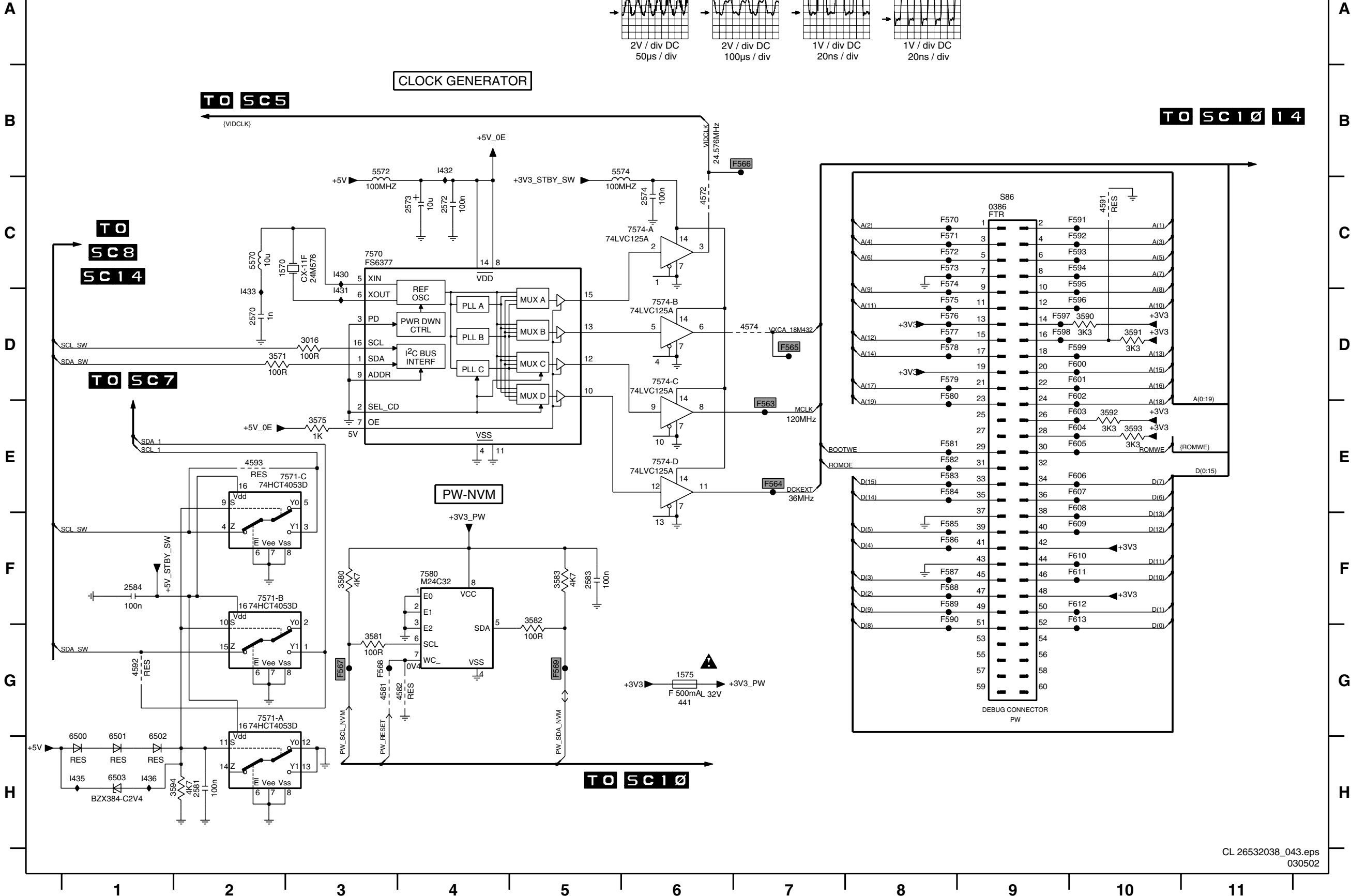
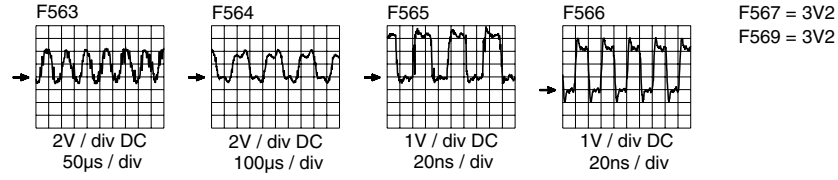

- 0386 C9
- 1570 C2
- 1575 G6
- 2570 D2
- 2572 C4
- 2573 C4
- 2574 C6
- 2581 H2
- 2583 F5
- 2584 F1
- 3016 D3
- 3571 D2
- 3575 E3
- 3580 F3
- 3581 G3
- 3582 F5
- 3583 F5
- 3590 D10
- 3591 D10
- 3592 E10
- 3593 E10
- 3594 H2
- 4572 C6
- 4574 D7
- 4581 G3
- 4582 G4
- 4591 C10
- 4592 G1
- 4593 E2
- 5570 C2
- 5572 B3
- 5574 B5
- 6500 G1
- 6501 G1
- 6502 G1
- 6503 H1
- 7570 C3
- 7571-A G2
- 7571-B E3
- 7571-C E3
- 7574-A C6
- 7574-B D6
- 7574-C D6
- 7574-D E6
- 7580 F4
- F563 E7
- F565 E7
- F566 B7
- F567 G3
- F568 G3
- F569 G5
- F570 C8
- F571 C8
- F572 C8
- F573 C8
- F574 C8
- F575 D8
- F576 D8
- F577 D8
- F578 D8
- F579 D8
- F580 D8
- F581 E8
- F582 E8
- F583 E8
- F584 E8
- F585 F8
- F586 F8
- F587 F8
- F588 F8
- F589 F8
- F590 F8
- F591 C10
- F592 C10
- F593 C10
- F594 C10
- F595 C10
- F596 D10
- F597 D9
- F598 D9
- F599 D10
- F600 D10
- F601 D10
- F602 D10
- F603 E10
- F604 E10
- F605 E10
- F606 E10
- F607 E10
- F608 E10
- F609 F10
- F610 F10
- F611 F10
- F612 F10
- F613 F10
- I430 C3
- I431 D3
- I432 B4
- I433 D2
- I435 H1
- I436 H1

SCAVIO Panel: PW Scaler and Memory

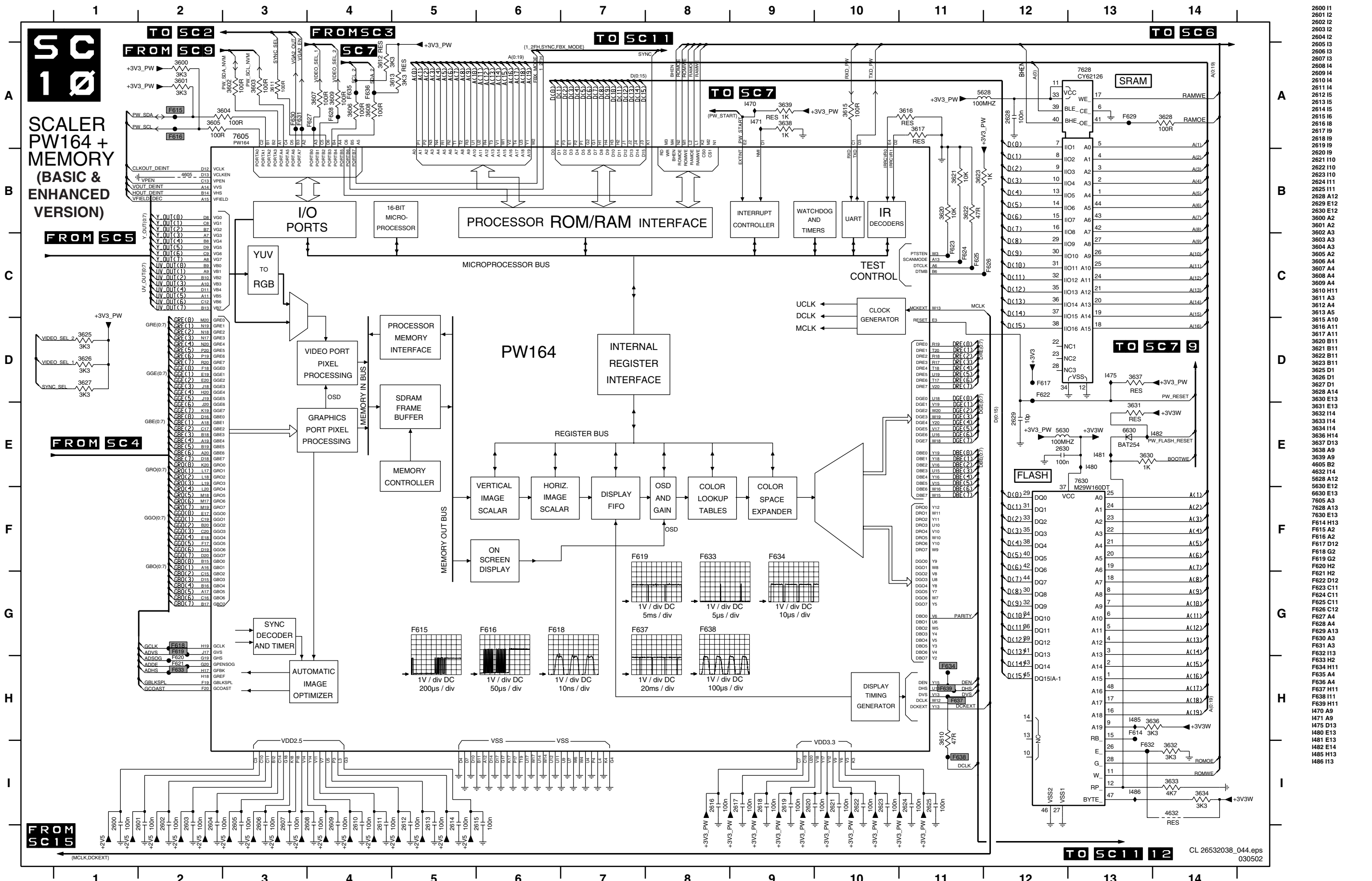

- 2600 I1
- 2601 I2
- 2602 I2
- 2603 I2
- 2604 I2
- 2605 I3
- 2606 I3
- 2607 I3
- 2608 I4
- 2609 I4
- 2610 I4
- 2611 I4
- 2612 I5
- 2613 I5
- 2614 I5
- 2615 I6
- 2616 I8
- 2617 I9
- 2618 I9
- 2619 I9
- 2620 I9
- 2621 I10
- 2622 I10
- 2623 I10
- 2624 I11
- 2625 I11
- 2626 I12
- 2627 E12
- 2628 E12
- 2629 E12
- 2630 E12
- 2631 A2
- 2632 A3
- 2633 A3
- 2634 A3
- 2635 A2
- 2636 A4
- 2637 A4
- 2638 A4
- 2639 A4
- 2640 A4
- 2641 A3
- 2642 A4
- 2643 A5
- 2644 A10
- 2645 A11
- 2646 A11
- 2647 A11
- 2648 A11
- 2649 A11
- 2650 A11
- 2651 A11
- 2652 A11
- 2653 A11
- 2654 A11
- 2655 A11
- 2656 A11
- 2657 A11
- 2658 A11
- 2659 A11
- 2660 A11
- 2661 A11
- 2662 A11
- 2663 A11
- 2664 A11
- 2665 A11
- 2666 A11
- 2667 A11
- 2668 A11
- 2669 A11
- 2670 A11
- 2671 A11
- 2672 A11
- 2673 A11
- 2674 A11
- 2675 A11
- 2676 A11
- 2677 A11
- 2678 A11
- 2679 A11
- 2680 A11
- 2681 A11
- 2682 A11
- 2683 A11
- 2684 A11
- 2685 A11
- 2686 A11
- 2687 A11
- 2688 A11
- 2689 A11
- 2690 A11
- 2691 A11
- 2692 A11
- 2693 A11
- 2694 A11
- 2695 A11
- 2696 A11
- 2697 A11
- 2698 A11
- 2699 A11
- 2700 A11

SCAVIO Panel: Back-End EPLD

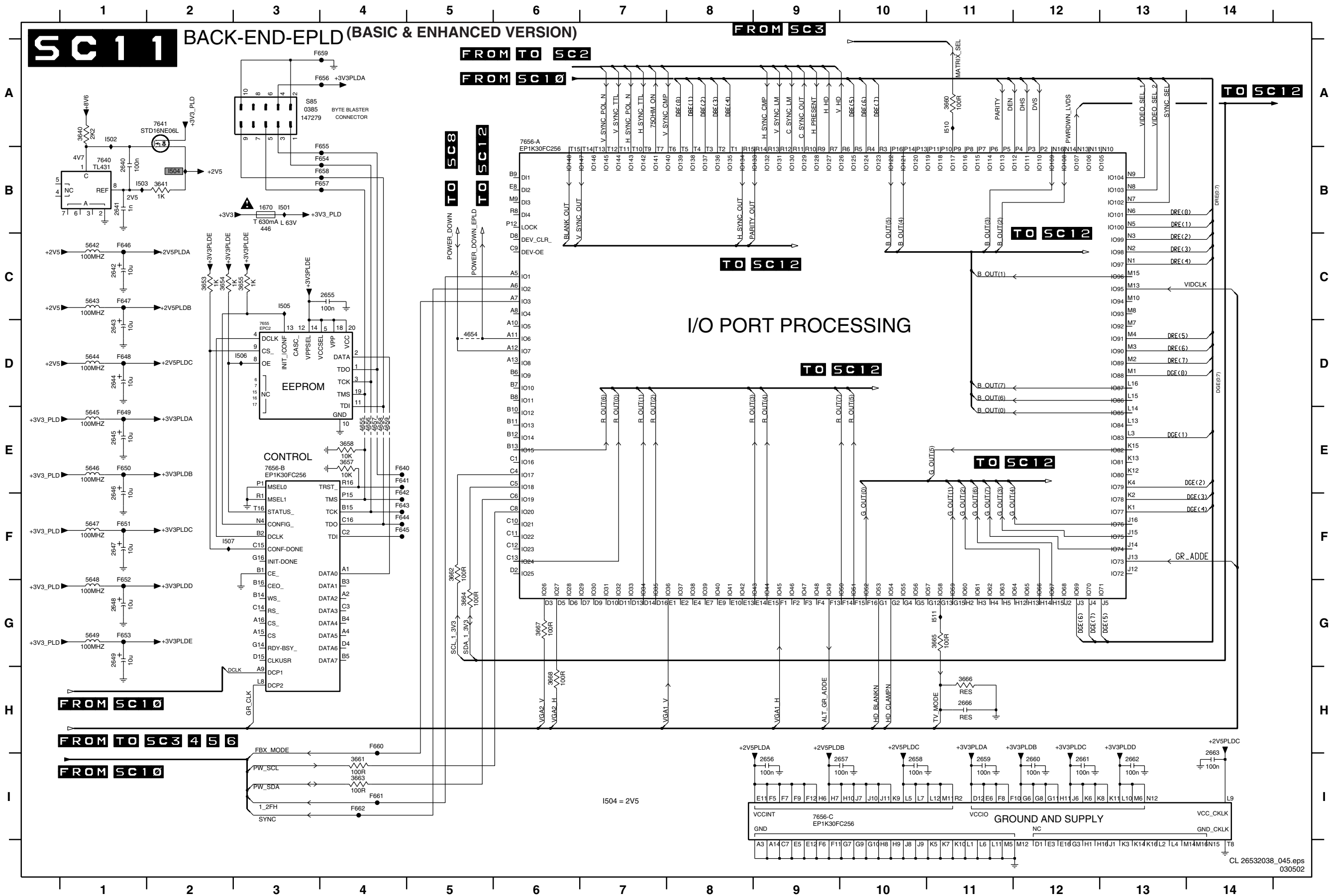

- 0385 A3
- 1670 B3
- 2640 B1
- 2641 B1
- 2642 C1
- 2643 D1
- 2644 D1
- 2645 E1
- 2646 F1
- 2647 F1
- 2648 G1
- 2649 G1
- 2655 C4
- 2656 I9
- 2657 I10
- 2658 I10
- 2659 I11
- 2660 I12
- 2661 I12
- 2662 I13
- 2663 I14
- 2666 H11
- 3640 A1
- 3641 B2
- 3653 C2
- 3654 C2
- 3655 C3
- 3657 E4
- 3660 A11
- 3661 I4
- 3662 F5
- 3663 I4
- 3664 G5
- 3665 G11
- 3666 H6
- 4654 D5
- 4655 E4
- 4656 E4
- 4657 E4
- 4658 E4
- 4659 E4
- 5642 C1
- 5643 C1
- 5644 D1
- 5645 E1
- 5646 E1
- 5647 F1
- 5648 G1
- 5649 G1
- 7640 B1
- 7641 A2
- 7655 D3
- 7656-A A6
- 7656-B E3
- 7656-C I9
- F640 E4
- F641 E4
- F642 F4
- F643 F4
- F644 F4
- F645 F4
- F646 C1
- F647 C1
- F648 D1
- F649 E1
- F650 E1
- F651 F1
- F652 G1
- F653 G1
- F654 B4
- F655 B4
- F656 A4
- F657 B4
- F658 B4
- F660 H4
- F661 I4
- F662 I4
- I501 B3
- I502 A1
- I503 B1
- I504 B2
- I505 C3
- I506 D3
- I507 F2
- I510 A11
- I511 G11

SCAVIO Panel: Back-End LVDS Output

SC12 BACK-END-LVDS-OUTPUT
(BASIC & ENHANCED VERSION)

A
B
C
D
E
F
G
H

A
B
C
D
E
F
G
H

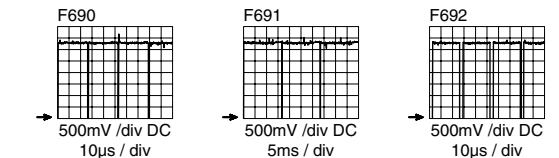
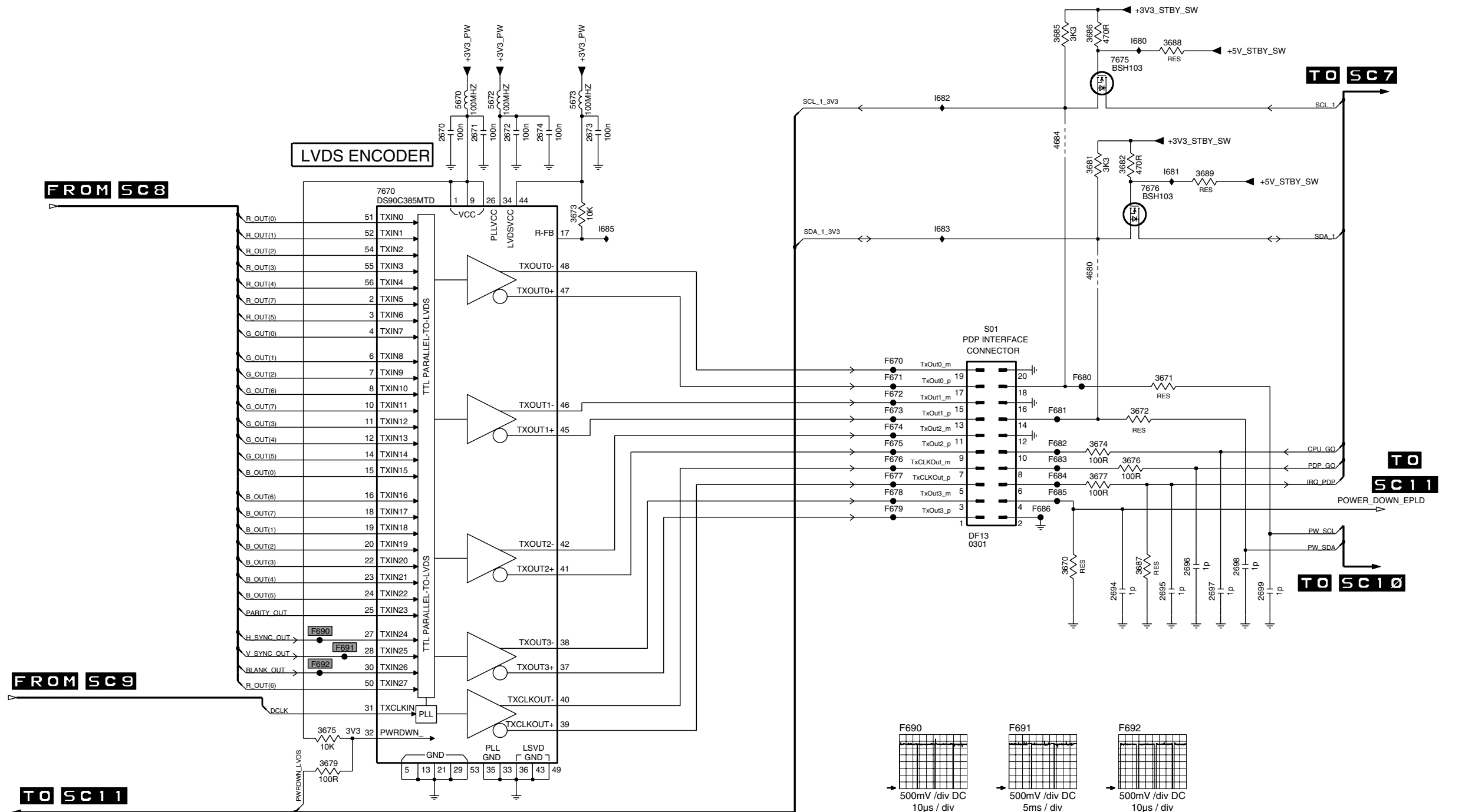

- 0301 E9
- 2670 B5
- 2671 B5
- 2672 B5
- 2673 B6
- 2674 B6
- 2694 F11
- 2695 F11
- 2696 F11
- 2697 F11
- 2698 F12
- 2699 F12
- 3670 F10
- 3671 D11
- 3672 D11
- 3673 C6
- 3674 E10
- 3675 G4
- 3676 E11
- 3677 E10
- 3679 G4
- 3681 B10
- 3682 B11
- 3685 A10
- 3687 F11
- 3688 A11
- 3689 B11
- 4680 C10
- 4684 B10
- 5670 B5
- 5672 B5
- 5673 B6
- 7670 B4
- 7675 A11
- 7676 B11
- F670 D9
- F671 D9
- F672 D9
- F673 D9
- F674 D9
- F675 E9
- F676 E9
- F677 E9
- F678 E9
- F679 E9
- F680 D10
- F681 D10
- F682 E10
- F683 E10
- F684 E10
- F685 E10
- F686 E10
- F690 F4
- F691 F4
- F692 G4
- I680 A11
- I681 B11
- I682 B9
- I683 C9
- I685 C6

SCAVIO Panel: Audio Source Select

SC13 AUDIO SOURCE SELECT (BASIC & ENHANCED VERSION)

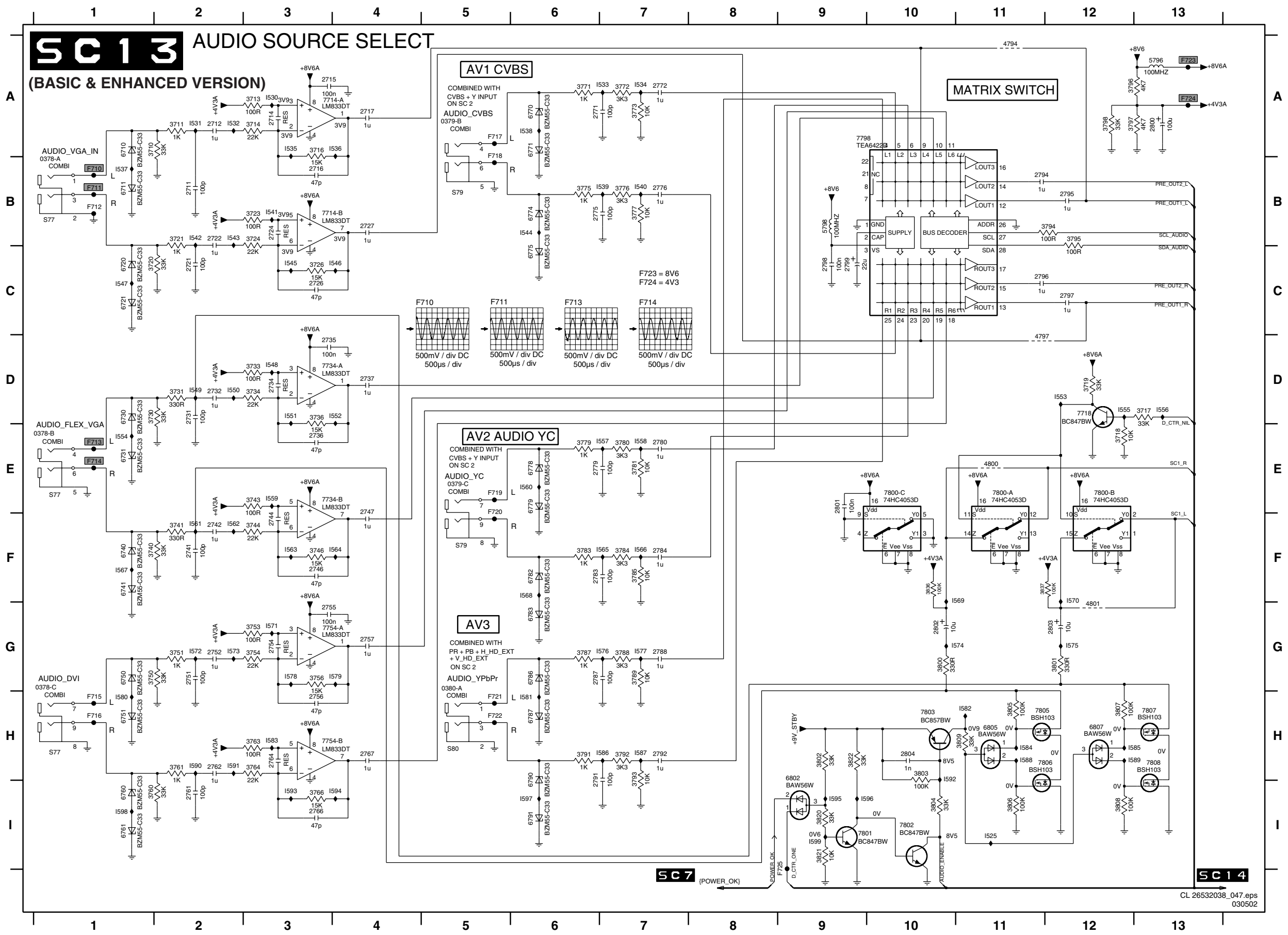

0378-A A1	3800 G10	1565 F7
0378-B E1	3801 G12	1566 F7
0378-C G1	3802 H9	1567 F1
0379-B A5	3803 H10	1568 F6
0379-C E5	3804 I10	1569 F11
0380-A G5	3805 H11	1570 F12
2711 B2	3806 I11	1571 G3
2712 A2	3807 H12	1572 G2
2714 A3	3808 I12	1573 G2
2715 A3	3809 H11	1574 G11
2716 B3	3820 I9	1575 G12
2717 A4	3821 I9	1576 G7
2721 C2	3822 H9	1577 G7
2722 B2	3836 F10	1578 G3
2724 B3	3837 F11	1579 G4
2726 C3	4794 A11	1580 H1
2727 B4	4797 D11	1581 H6
2731 D2	4800 E11	1582 H11
2732 D2	4801 G12	1583 H3
2734 D3	5796 A13	1584 H11
2735 D3	5798 B9	1585 H13
2736 E3	6710 A1	1586 H7
2737 D4	6711 B1	1587 H7
2741 F2	6720 C1	1588 H11
2742 F2	6721 C1	1589 H13
2744 F3	6730 D1	1590 H2
2746 F3	6731 E1	1591 H2
2747 F4	6740 F1	1592 H10
2751 G2	6741 F1	1593 I3
2752 G2	6750 G1	1594 I4
2754 G3	6751 H1	1595 I9
2755 G3	6760 I1	1596 I10
2756 H3	6761 I1	1597 I6
2757 H4	6770 A6	1598 I1
2761 I2	6771 A6	1599 I9
2762 H2	6774 B6	
2764 H3	6775 C6	
2766 I3	6778 E6	
2767 H4	6779 E6	
2771 A6	6782 F6	
2772 A7	6783 G6	
2775 B6	6786 G6	
2776 B7	6787 H6	
2779 E6	6790 H6	
2780 E7	6791 I6	
2783 F6	6802 I9	
2784 F7	6805 H11	
2787 G6	6807 H12	
2788 G7	7714-A A3	
2791 H6	7714-B B3	
2792 H7	7718 D12	
2794 B11	7734-A D3	
2795 B12	7734-B E3	
2796 C11	7754-A G3	
2797 C12	7754-B H3	
2798 C9	7798 A9	
2799 C9	7800-A E11	
2800 A13	7800-B E12	
2801 E9	7800-C E10	
2802 G10	7801 I9	
2803 G12	7802 I10	
2804 H10	7803 H10	
2710 A1	7805 H11	
3711 A2	7806 H12	
3713 A3	7807 H13	
3714 A3	7808 H13	
3716 A3	7710 B1	
3717 D13	7711 B1	
3718 E12	7712 B1	
3719 D12	7713 E1	
3720 C1	7714 E1	
3721 B2	7715 H1	
3723 B3	7716 H1	
3724 B3	7717 A5	
3726 C3	7718 B5	
3730 D1	7719 E5	
3731 D2	7720 F5	
3733 D3	7721 H5	
3734 D3	7722 H5	
3736 D3	7723 A13	
3740 F1	7724 A13	
3741 F2	7725 I9	
3743 E3	1525 I11	
3744 F3	1530 A3	
3746 F3	1531 A2	
3750 G1	1532 A2	
3751 G2	1533 A7	
3753 G3	1534 A7	
3754 G3	1535 A3	
3756 G3	1536 A4	
3760 I1	1537 B1	
3761 H2	1538 A6	
3763 H3	1539 B7	
3764 H3	1540 B7	
3766 I3	1541 B3	
3771 A6	1542 B2	
3772 A7	1543 B2	
3773 B6	1544 B6	
3776 B7	1545 B6	
3777 B7	1546 C4	
3779 E6	1547 C1	
3780 E7	1548 D3	
3781 E7	1549 D2	
3783 F6	1550 D2	
3784 F7	1551 D3	
3785 F7	1552 D4	
3787 G6	1553 D12	
3788 G7	1554 E1	
3789 G7	1555 D12	
3791 H6	1556 D13	
3792 H7	1557 E7	
3793 H7	1558 E7	
3794 B12	1559 E3	
3795 B12	1560 E6	
3796 A12	1561 F2	
3797 A12	1562 F2	
3798 A12	1563 F3	
3799 A12	1564 F4	

SCAVIO Panel: Audio Processor

SC14 AUDIO PROCESSOR

(BASIC & ENHANCED VERSION)

FROM TO SC7 9 13

AUDIO PROCESSOR

A
B
C
D
E
F
G
H
I

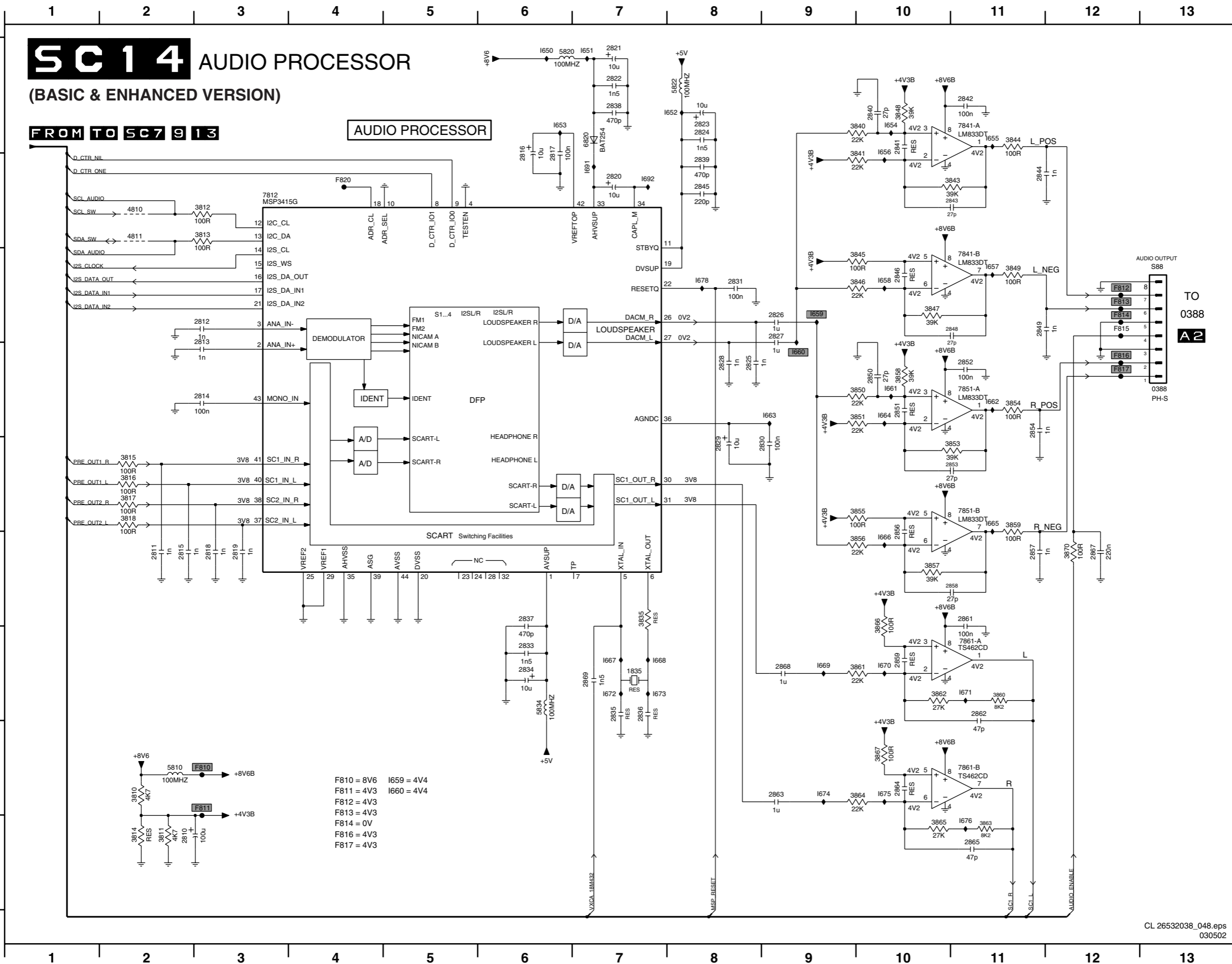

- 0388 D13
- 1835 G7
- 2810 I2
- 2811 F2
- 2812 C3
- 2813 D3
- 2814 D3
- 2815 F2
- 2816 B6
- 2817 B6
- 2818 F3
- 2819 F3
- 2820 B7
- 2821 A7
- 2822 A7
- 2823 A8
- 2824 A8
- 2825 D8
- 2826 C9
- 2827 C9
- 2828 D8
- 2829 E8
- 2830 E9
- 2831 C8
- 2832 G6
- 2833 G6
- 2834 G6
- 2835 G7
- 2836 G7
- 2837 F6
- 2838 A7
- 2839 B8
- 2840 A10
- 2841 A10
- 2842 A11
- 2843 B11
- 2844 B11
- 2845 B8
- 2846 C10
- 2848 C11
- 2849 C11
- 2850 D10
- 2851 D10
- 2852 D11
- 2853 E11
- 2854 D11
- 2855 F10
- 2857 F11
- 2858 F11
- 2859 G10
- 2861 F11
- 2862 G11
- 2863 H9
- 2864 H10
- 2867 F12
- 2868 G9
- 2869 G7
- 2810 H2
- 2811 I2
- 2812 B3
- 2813 B3
- 2814 I2
- 2815 E2
- 2816 E2
- 2817 E2
- 2818 E2
- 2835 F7
- 2840 A10
- 2841 B10
- 2843 B11
- 2844 A11
- 2845 C10
- 2847 C10
- 2848 A10
- 2849 C11
- 2850 D10
- 2851 D10
- 2853 E11
- 2854 D11
- 2855 E10
- 2856 F10
- 2857 F10
- 2858 D10
- 2859 E11
- 2860 G11
- 2861 G10
- 2862 G10
- 2863 H11
- 2864 H10
- 2865 H10
- 2866 F10
- 2867 H10
- 2870 F12
- 2810 B2
- 2811 B2
- 2810 H2
- 2820 A6
- 2822 A8
- 2834 G6
- 2820 A7
- 7812 B3
- 7841-A A11
- 7841-B C11
- 7851-A D11
- 7851-B E11
- 7861-A G11
- 7861-B H11
- F810 H3
- F811 H3
- F812 C12
- F813 C12
- F814 C12
- F815 C12
- F816 D12
- F817 D12

SC15 AUDIO DELAY LINE (BASIC & ENHANCED VERSION)

- 2870 C2
- 2874 F2
- 2880 B7
- 2881 E8
- 2882 E10
- 3879 H6
- 3880 G6
- 4871 G2
- 4872 G3
- 4873 G2
- 4874 G3
- 4875 G3
- 4882 E10
- 4883 E10
- 4884 F10
- 4885 F10
- 4886 F10
- 4887 F10
- 4888 F10
- 4889 F10
- 4890 G10
- 4891 G10
- 4892 G10
- 4893 G10
- 4894 G10
- 4895 G10
- 4896 G10
- 4897 H10
- 5870 A3
- 7870 B1
- 7874 E1
- 7879 G6
- 7880 B3
- 7881 E7
- 7882 E9
- F870 A3
- F871 G6
- F872 G6
- F873 H7
- F874 G11
- F875 F11

A

A

B

B

C

C

D

D

E

E

F

F

G

G

H

H

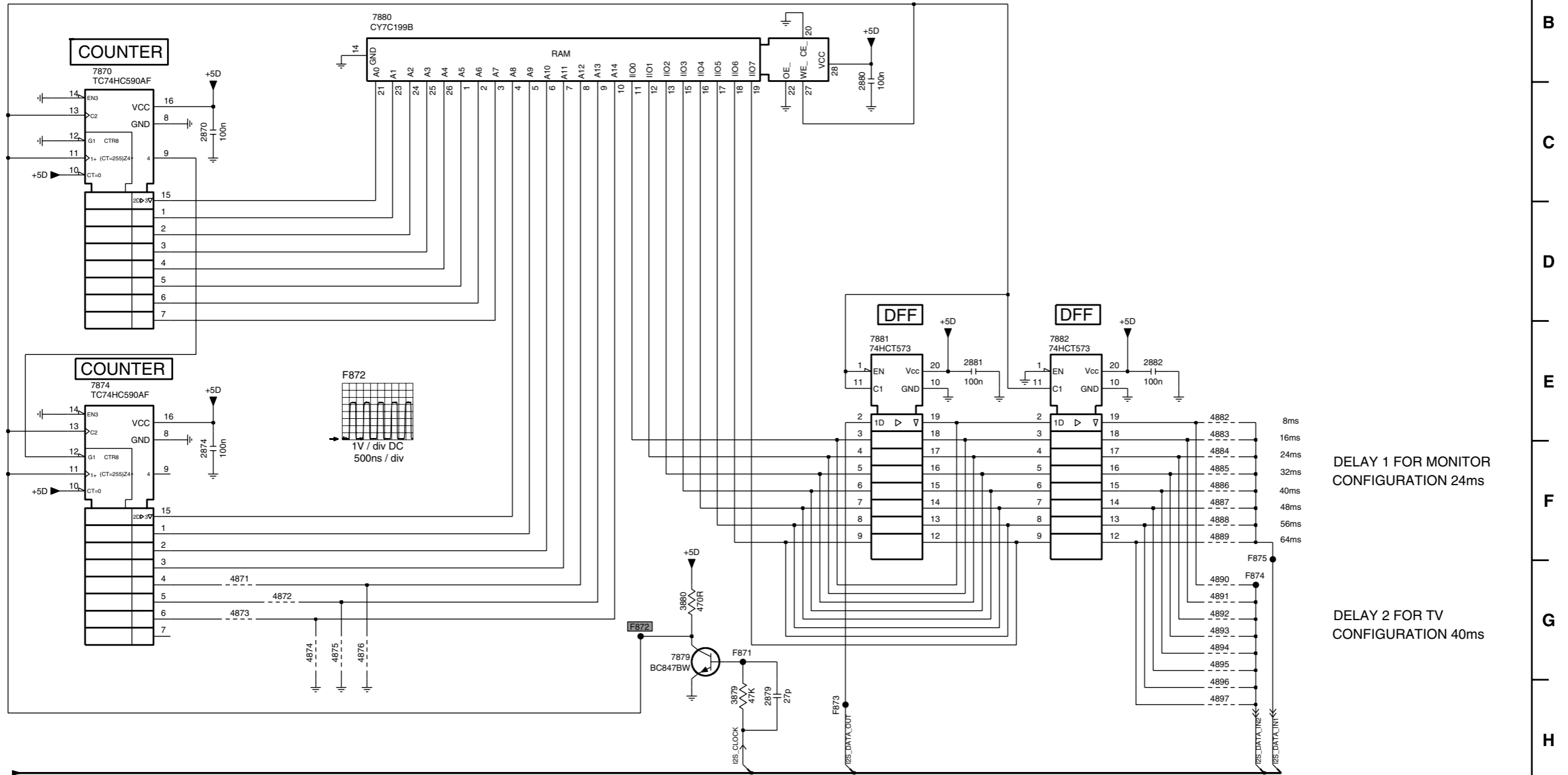
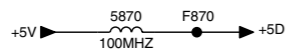

DELAY 1 FOR MONITOR
CONFIGURATION 24ms

DELAY 2 FOR TV
CONFIGURATION 40ms

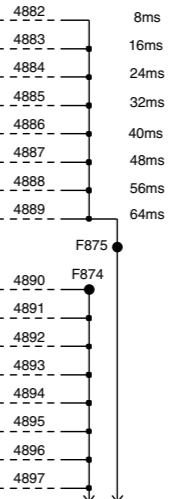

FROM SC14

VGA Connector Panel

VGA VGA CONNECTOR

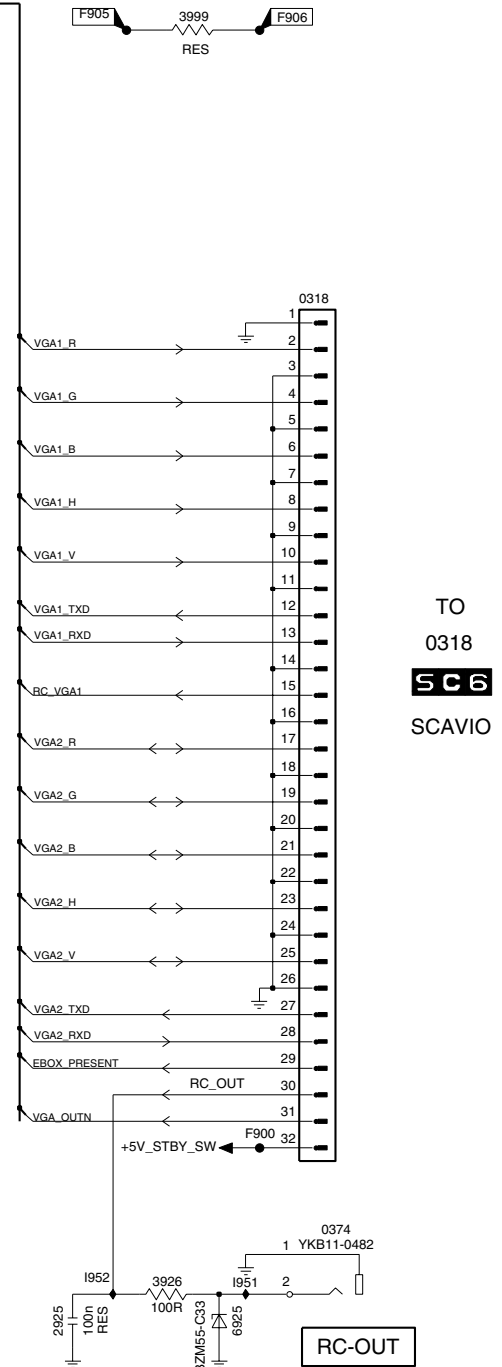
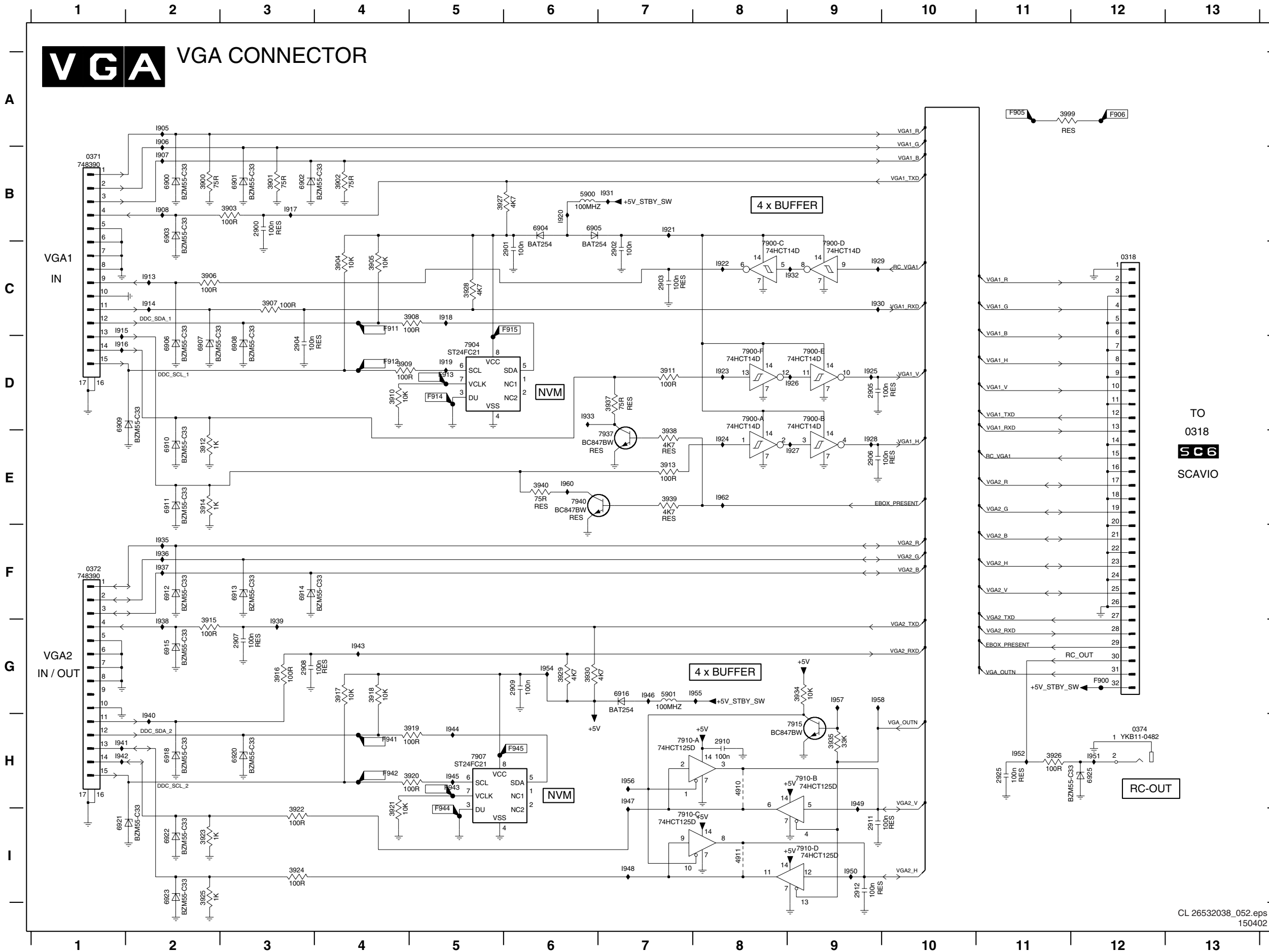

- 0318 C13
- 0371 B1
- 0372 F1
- 0374 H13
- 2900 B3
- 2901 C6
- 2902 C7
- 2903 C7
- 2904 D3
- 2905 D9
- 2906 E9
- 2907 G3
- 2908 G3
- 2909 G6
- 2910 H8
- 2911 I9
- 2912 I9
- 2925 H11
- 2926 D9
- 2927 E9
- 2928 E9
- 2929 C9
- 2930 C9
- 2931 B7
- 2932 C9
- 2933 D6
- 2934 B3
- 2935 F2
- 2936 F2
- 2937 F2
- 2938 G2
- 2939 G3
- 2940 H2
- 2941 H1
- 2942 H1
- 2943 G4
- 2944 H5
- 2945 H5
- 2946 G7
- 2947 H6
- 2948 I6
- 2949 H9
- 2950 I9
- 2951 H12
- 2952 H12
- 2953 I3
- 2954 G6
- 2955 G8
- 2956 H7
- 2957 G9
- 2958 G9
- 2960 E6
- 2962 E8
- 9908 B2
- 9913 C2
- 9914 C2
- 9915 C1
- 9916 D1
- 9917 B3
- 9918 C5
- 9919 D5
- 9920 B6
- 9921 B7
- 9922 C8
- 9923 D8
- 9924 E8
- 9925 D9
- 9926 D9
- 9927 E9
- 9928 E9
- 9929 C9
- 9930 C9
- 9931 B7
- 9932 C9
- 9933 D6
- 9934 B3
- 9935 F2
- 9936 F2
- 9937 F2
- 9938 G2
- 9939 G3
- 9940 H2
- 9941 H1
- 9942 H1
- 9943 G4
- 9944 H5
- 9945 H5
- 9946 G7
- 9947 H6
- 9948 I6
- 9949 H9
- 9950 I9
- 9951 H12
- 9952 H12
- 9953 I3
- 9954 G6
- 9955 G8
- 9956 H7
- 9957 G9
- 9958 G9
- 9960 E6
- 9962 E8