

AV1 Input

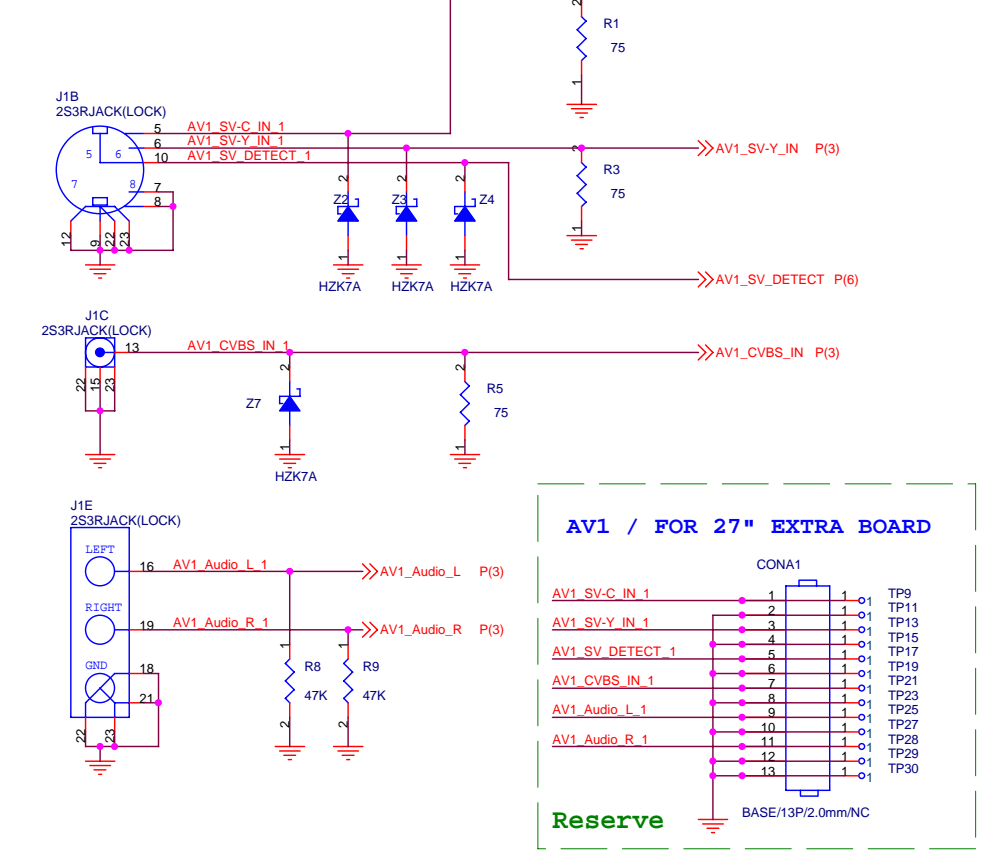

Tuner Input

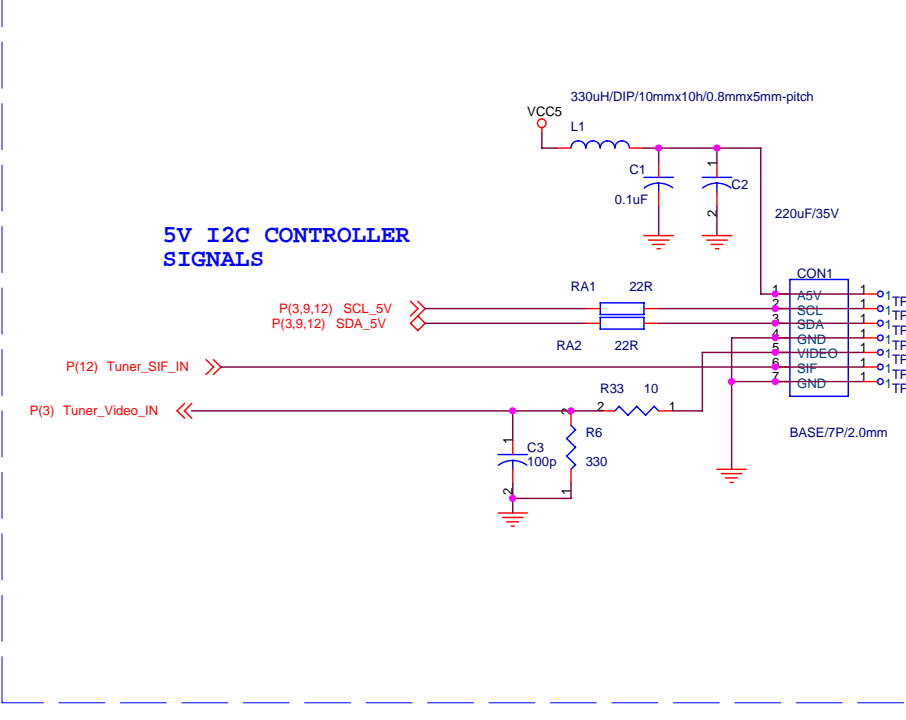

AV3 Input

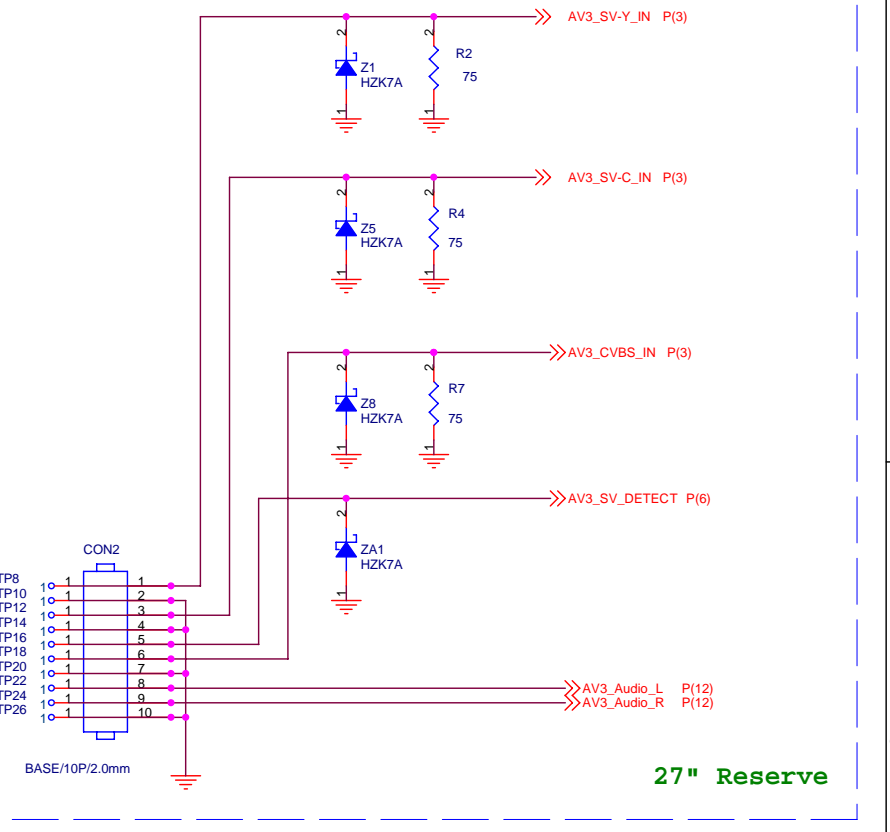

HDTV Input

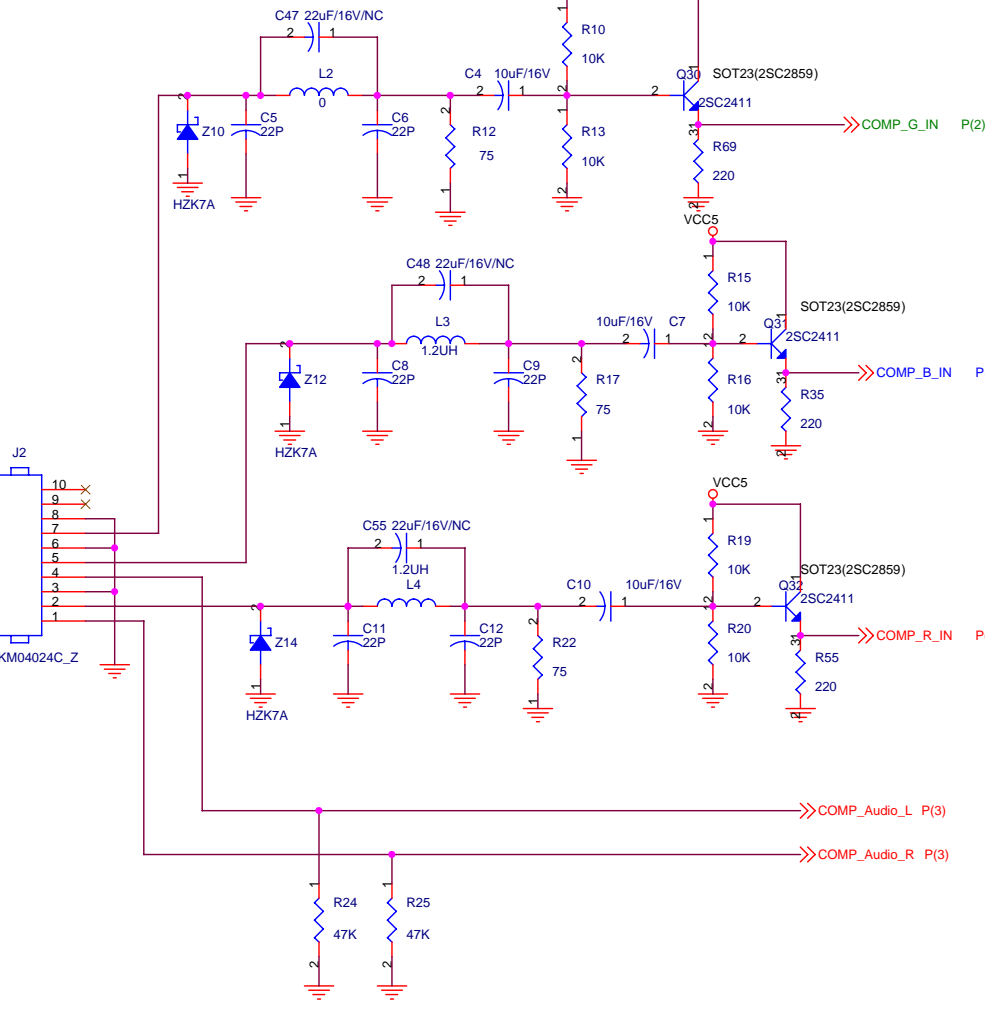

AV2 Input

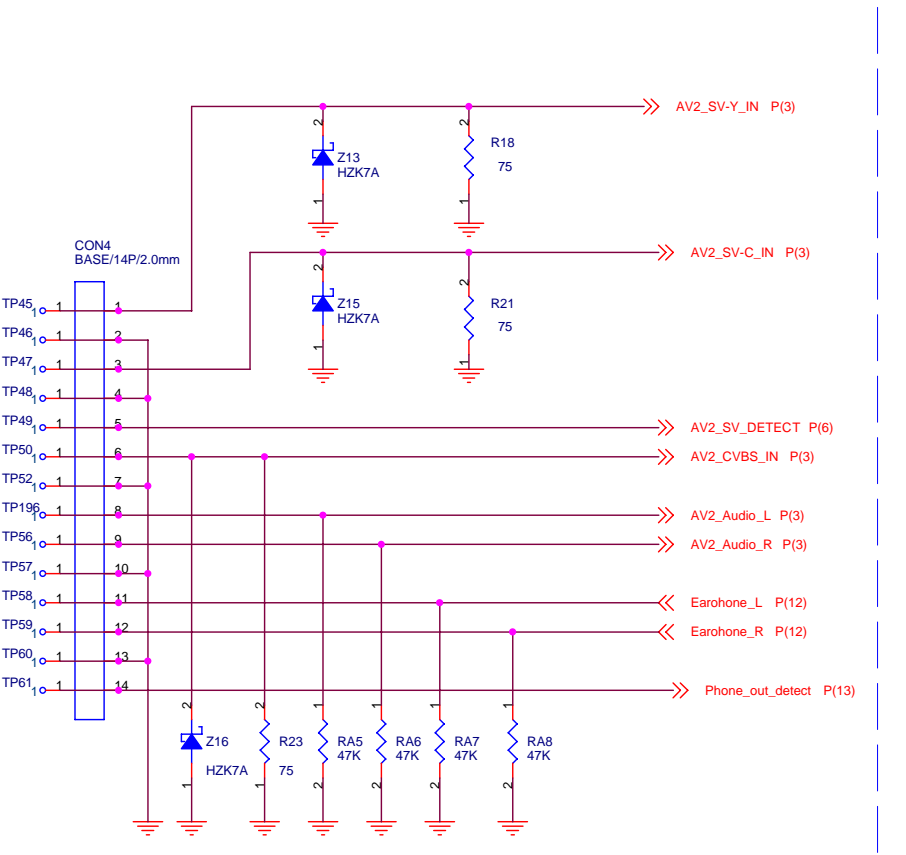

DTV Input

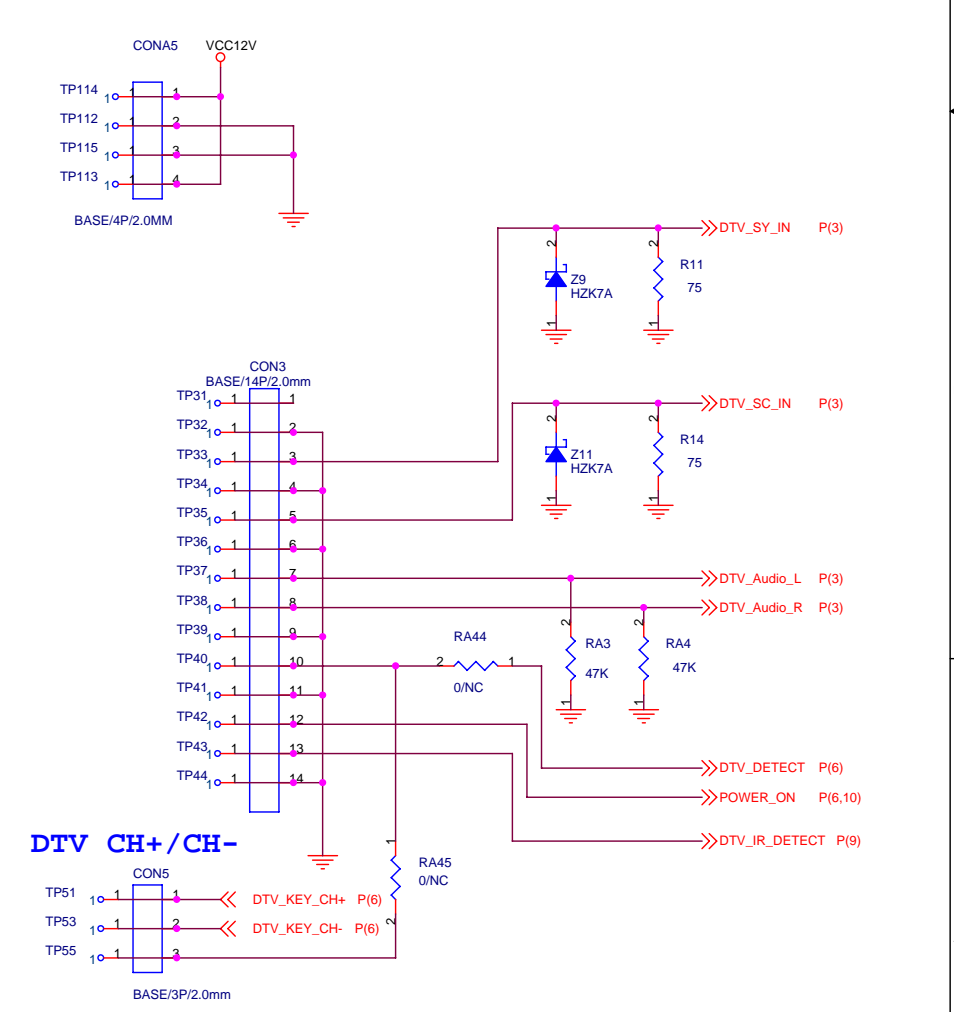

HDMI Input

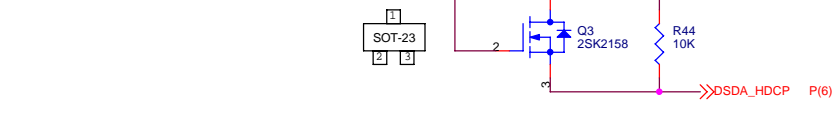
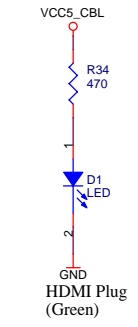
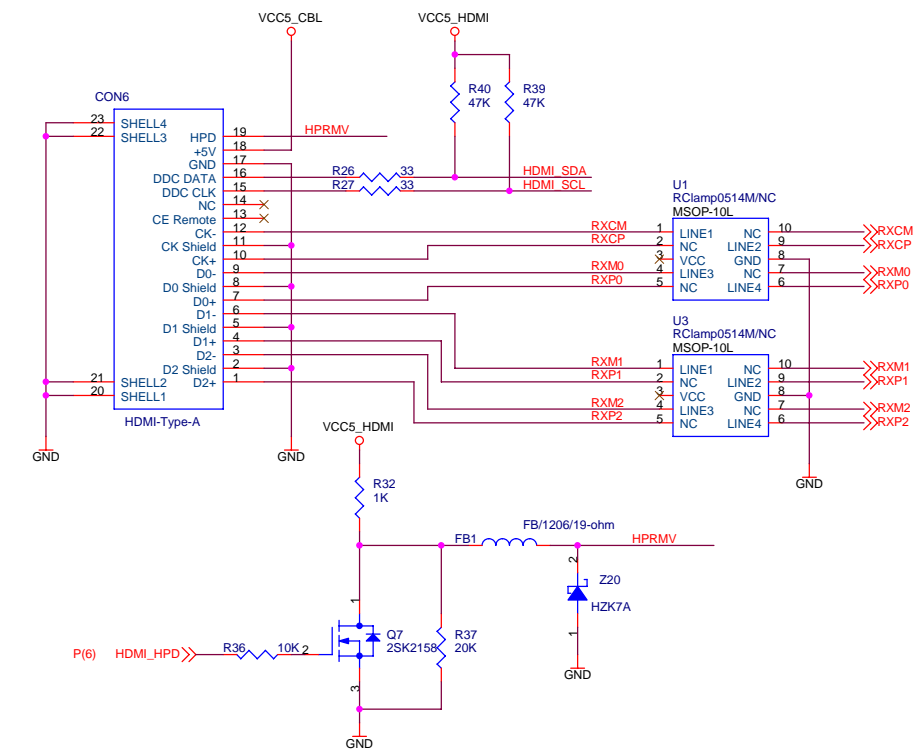

HDMI DDC

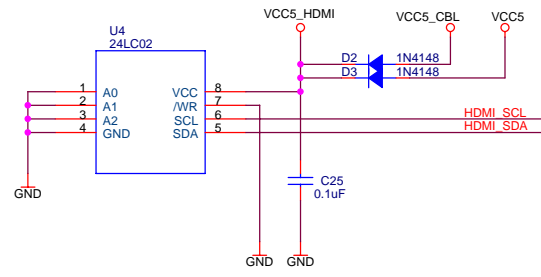

CARD Input

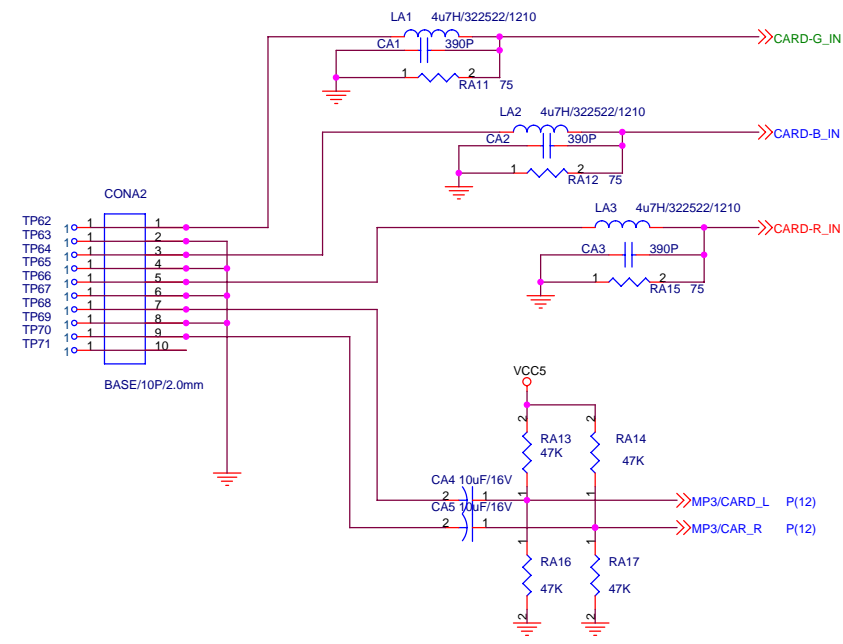

CARD Power & IR Input

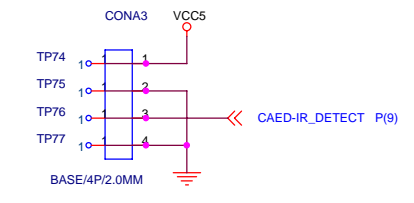

PC Input

5月30日修改

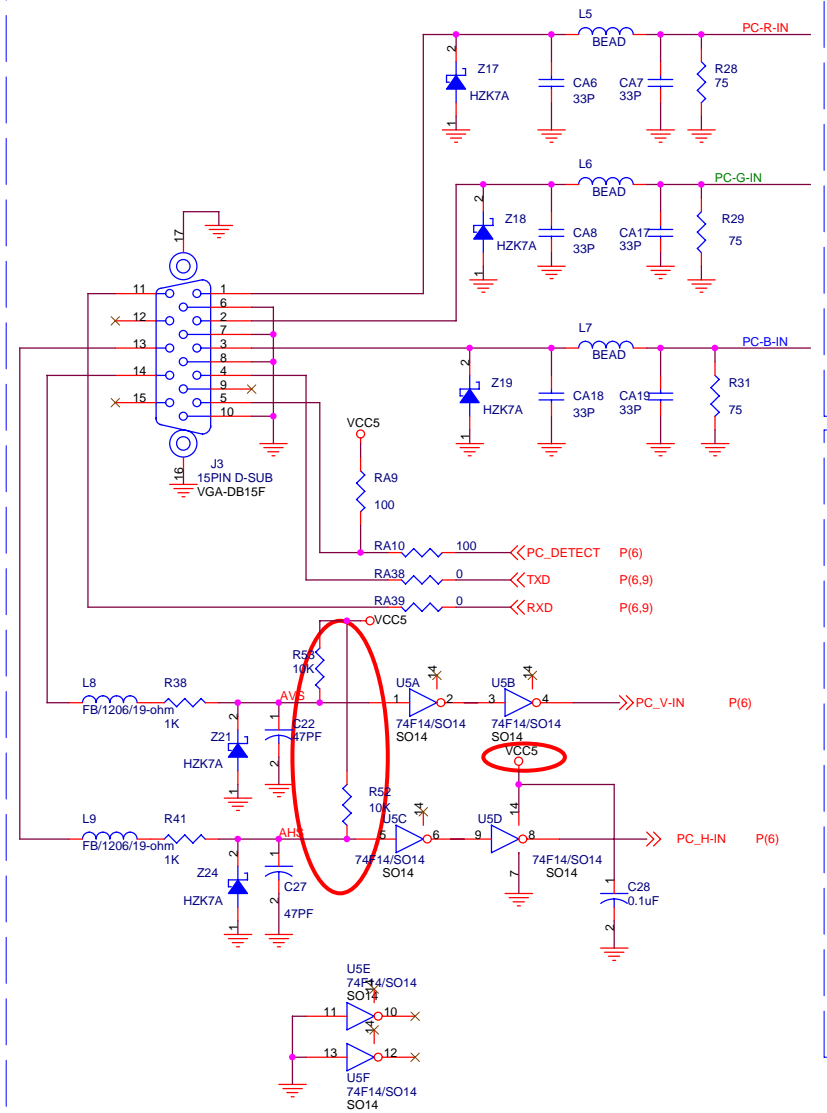

PC&YPbPr SWITCH

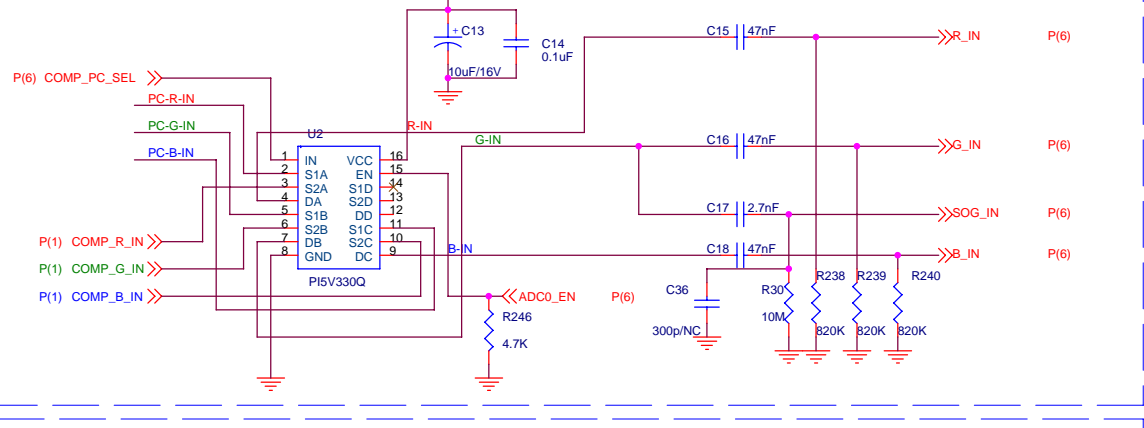

CARD&ATSC SWITCH

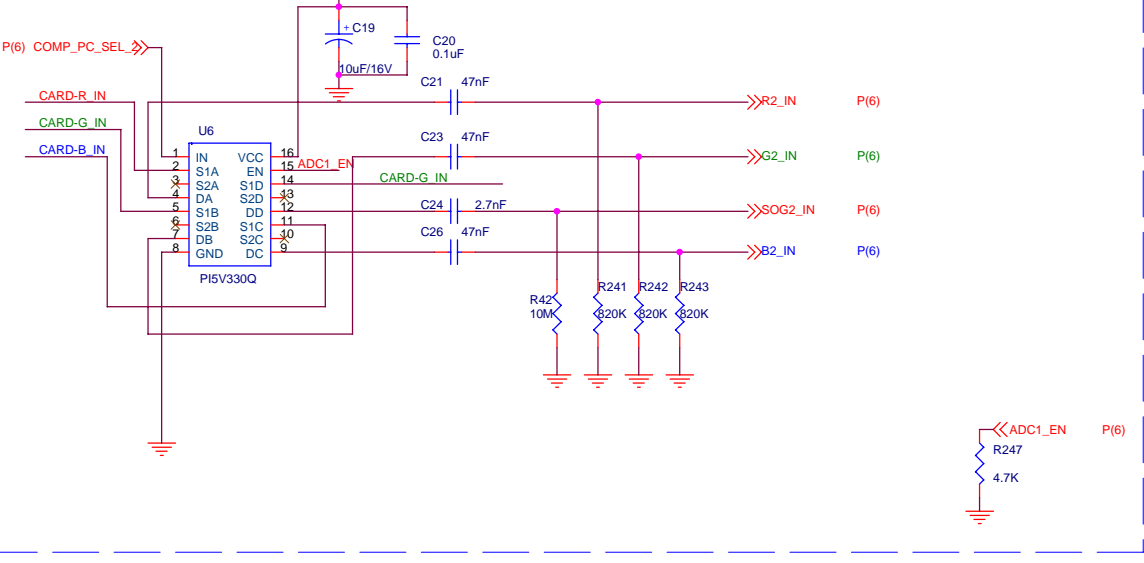

CYPRESS TECH. CO., LTD.

Title			SPV7030 - MAIN
Size	Document Number	Rev	
Custom	PC & HDMI INPUT	1.1	
Date:	Friday, August 11, 2006	Sheet	2 of 13

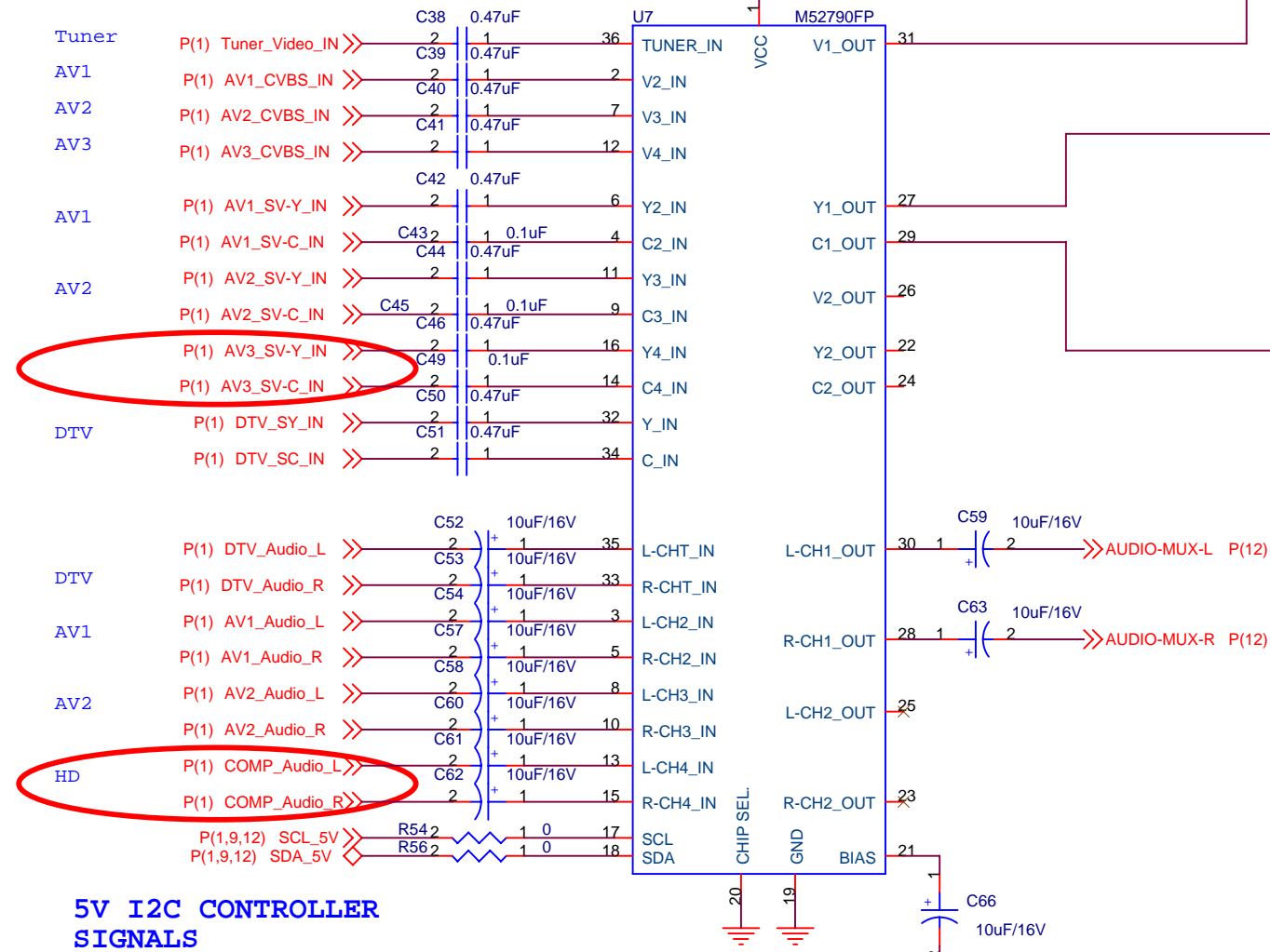
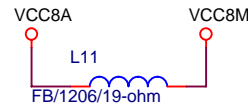

CHANNEL 1 :uPD64015
CHANNEL 2 :SPV516B

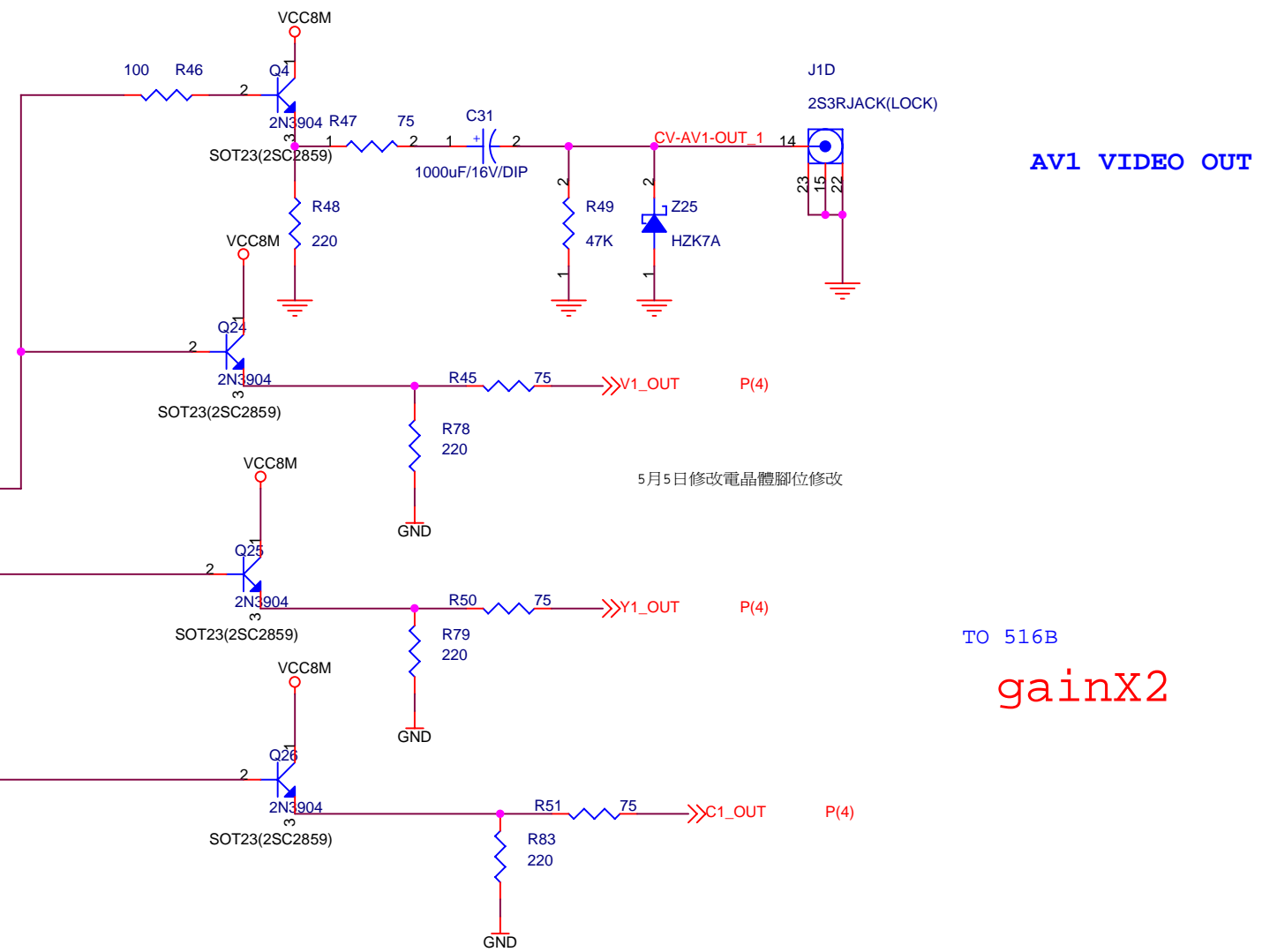

AV1 VIDEO OUT

TO 516B
gainX2

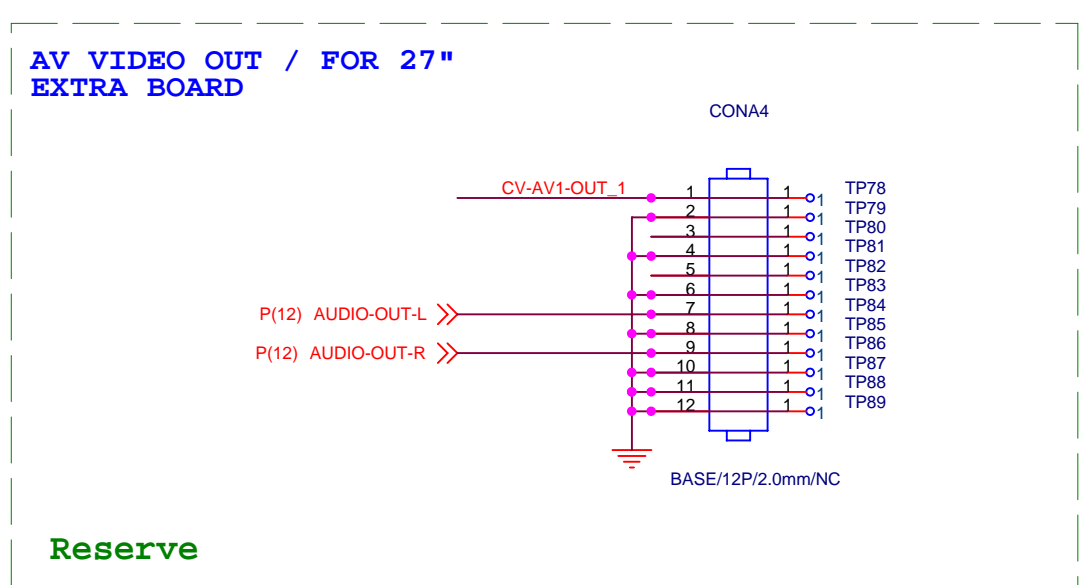

CYPRESS TECH. CO., LTD.		
Title SPV7030 - MAIN		
Size	Document Number CustomM52790FP	Rev 1.1
Date: Friday, August 11, 2006	Sheet 3 of 13	

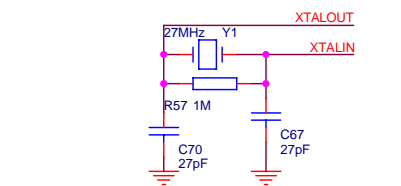

Crystal Circuit
External Capacitor for PLL

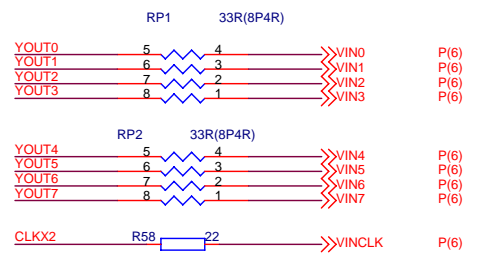

CCIR656 8BIT OUT

3.3V I2C CONTROLLER SIGNALS

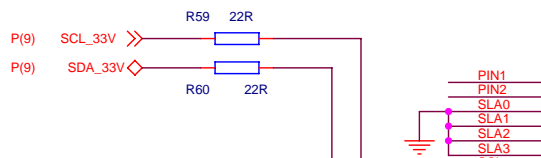

Reset Circuit

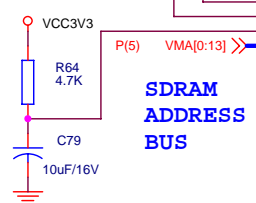

SDRAM CONTROLLER SIGNAL

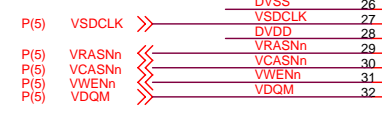

SDRAM ADDRESS BUS

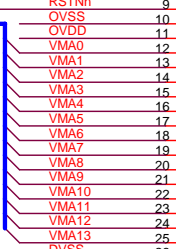

SDRAM DATA BUS



U8 SPV516B(128LQFP)/SUNPLUS

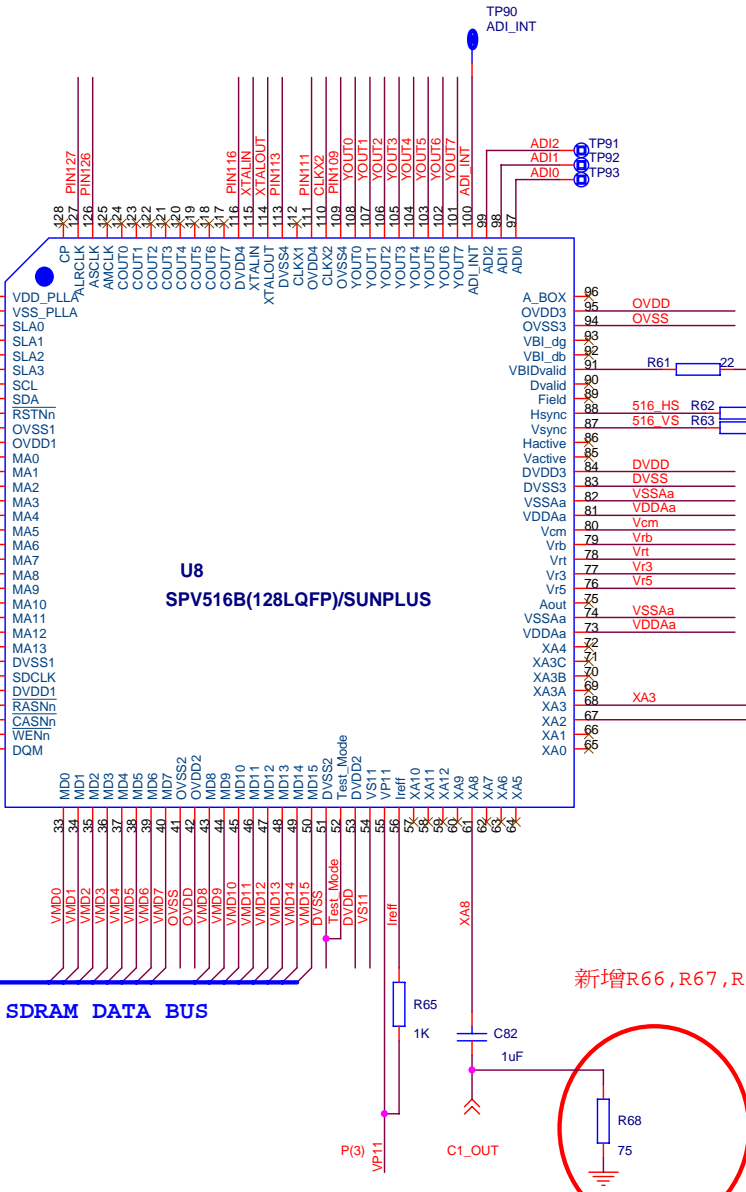

新增R66, R67, R68 (75ohm)

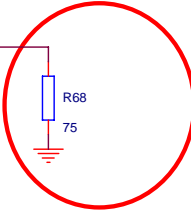
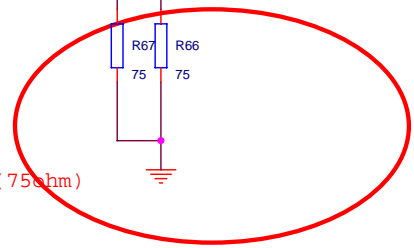

SOURCE POWER/GND (2.5V/3.3V)

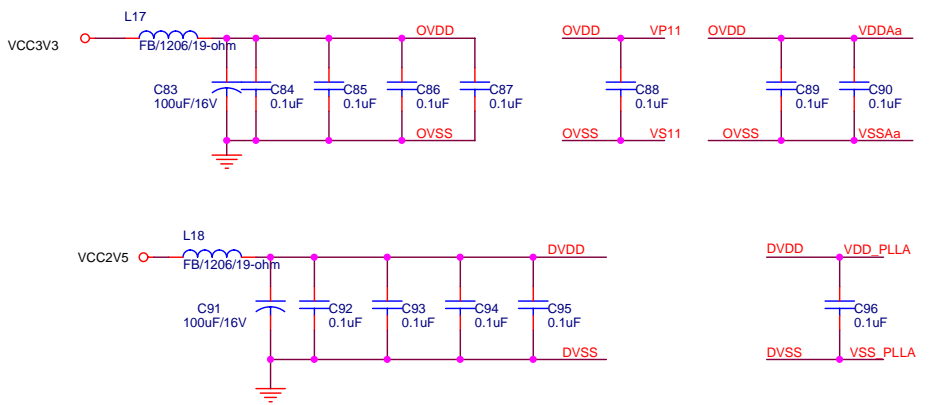

ADC bias Circuit

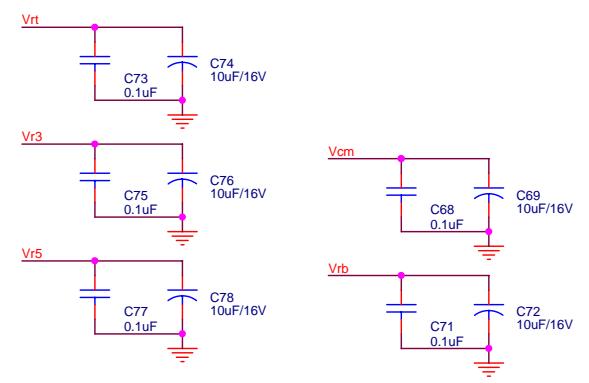

- VDD_PLLA PIN1
- VSSAa PIN2
- DVSS PIN109
- DVDD PIN111
- OVSS PIN113
- OVDD PIN116
- VDDAa PIN126
- VSS_PLLA PIN127

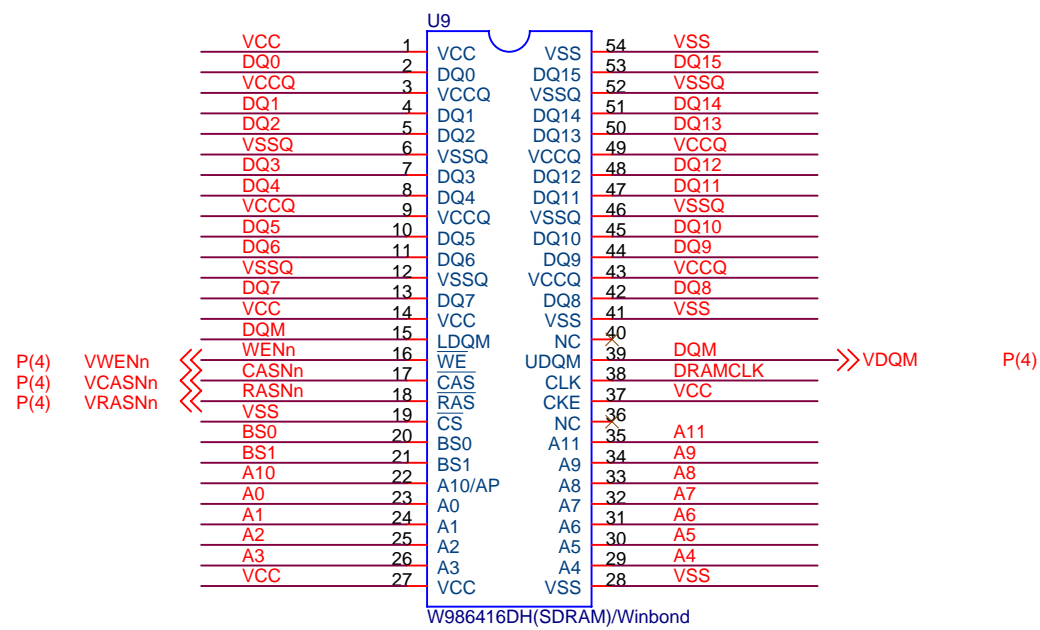

SDRAM DATA BUS

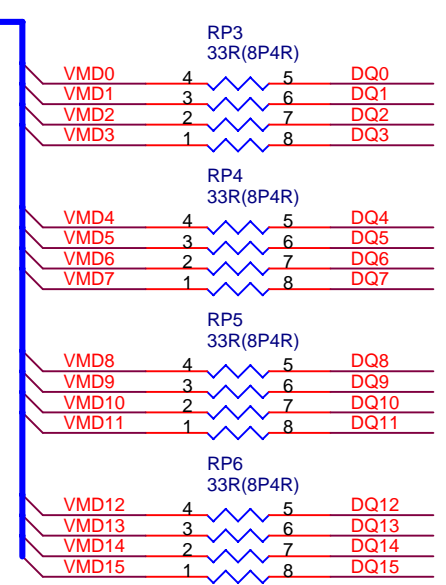

SDRAM ADDRESS BUS

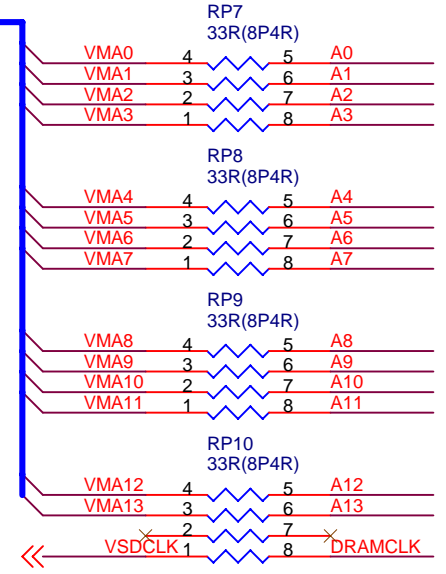

SDRAM CONTROLLER SIGNAL

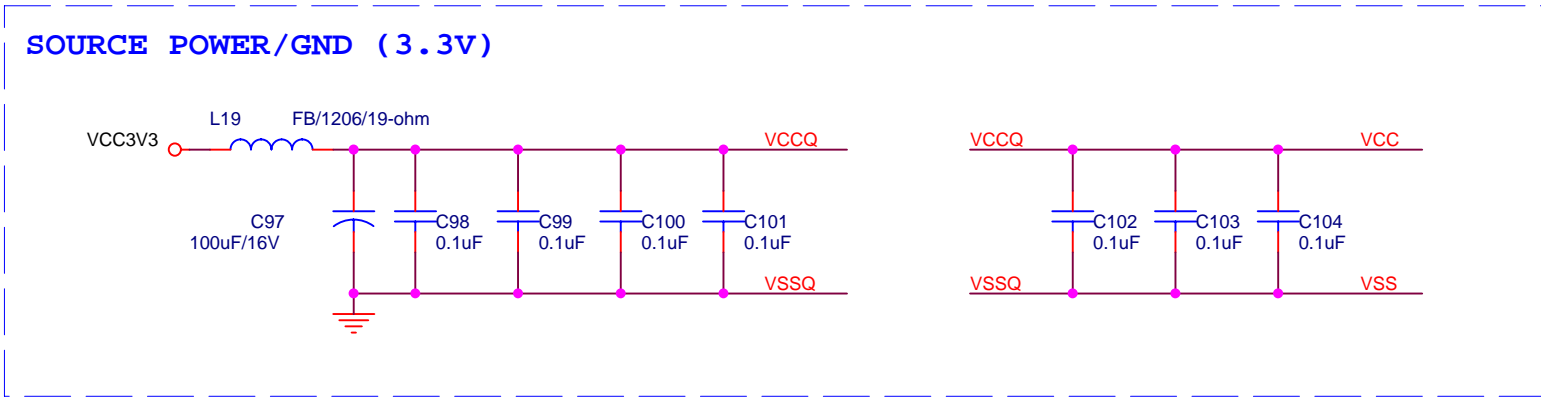

CYPRESS TECH. CO., LTD.		
Title: SPV7030 - MAIN		
Size B	Document Number: SPV516B SDRAM	Rev 1.1
Date: Friday, August 11, 2006	Sheet 5 of 13	

SPV7030 Input

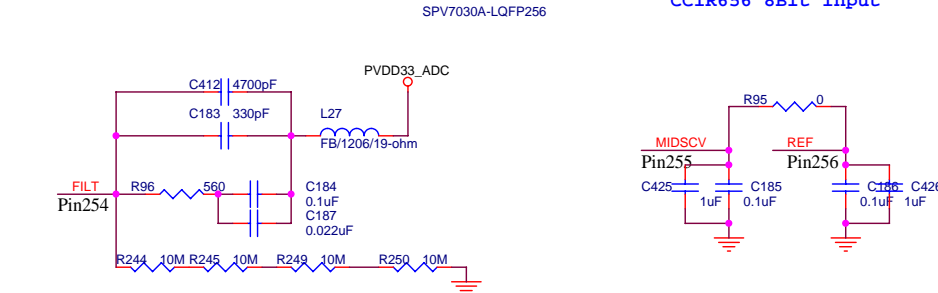
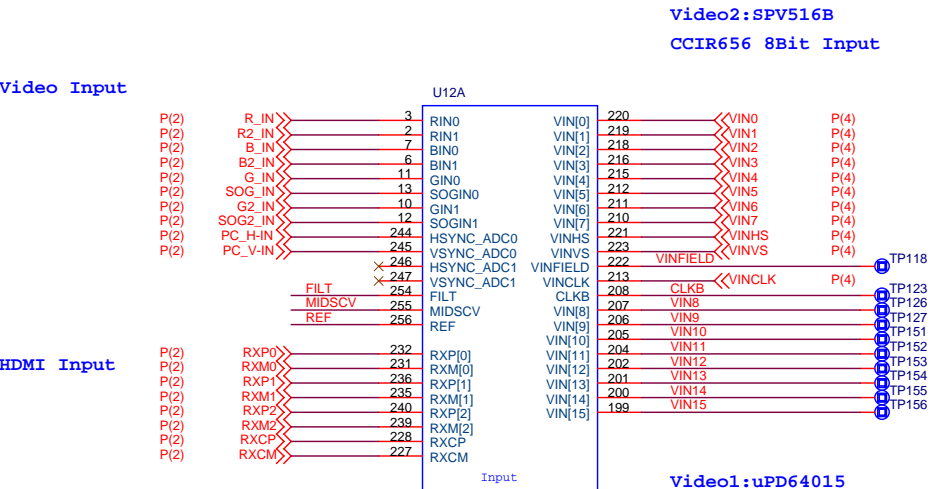

SPV7030 SDRAM and GPIO Port

SDRAM ADDRESS BUS

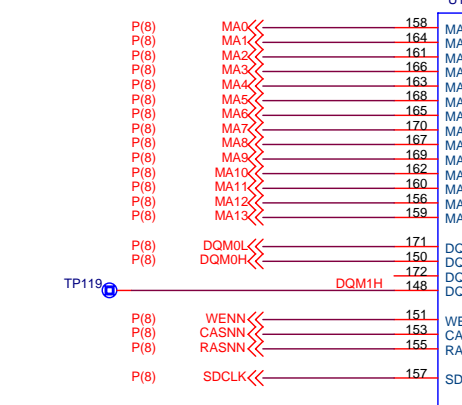

SDRAM DATA BUS

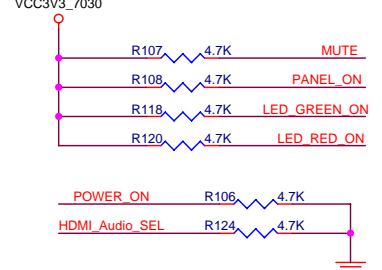
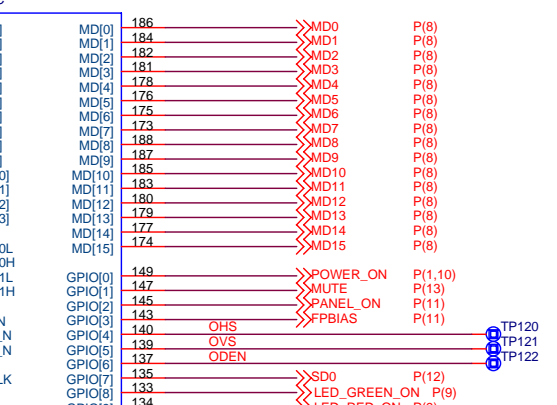

SDRAM CONTROLLER SIGNAL

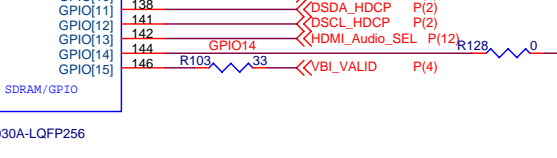

SPV7030 CPU and Misc

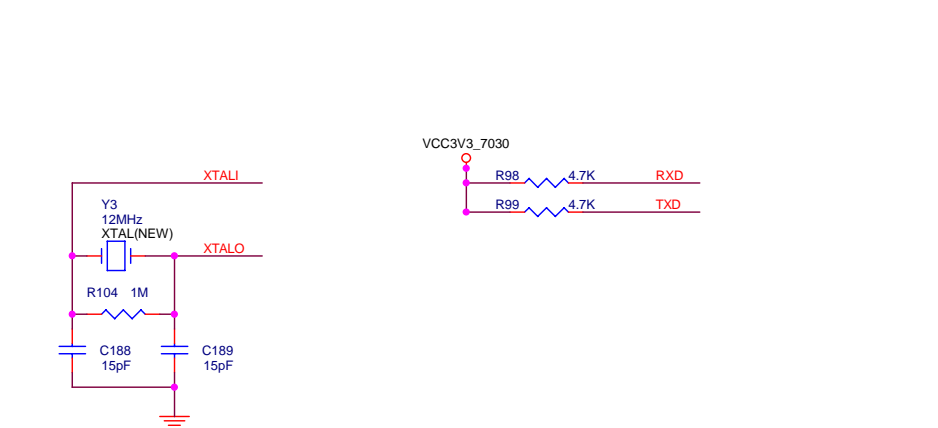
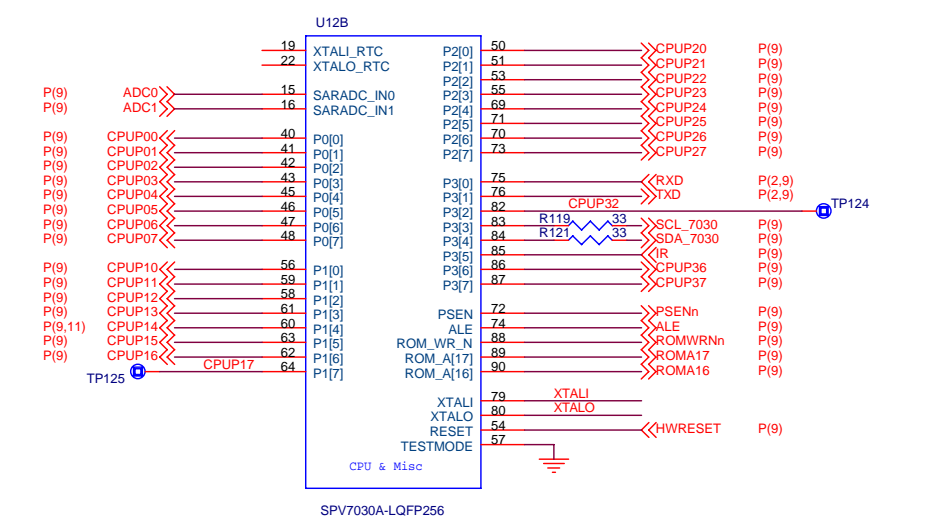

Crystal Circuit

SPV7030 Output

LVDS to Panel

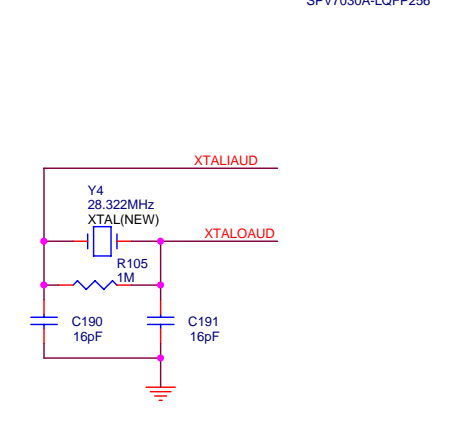
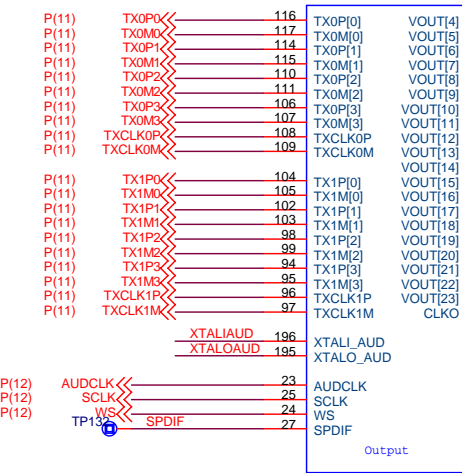

Crystal Circuit

DTV KEY Control

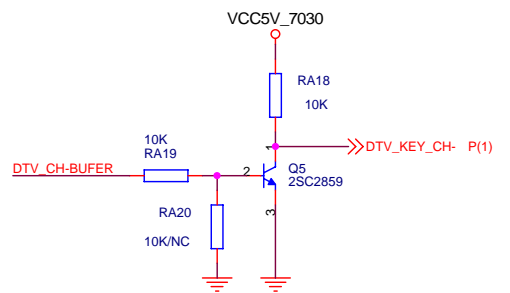
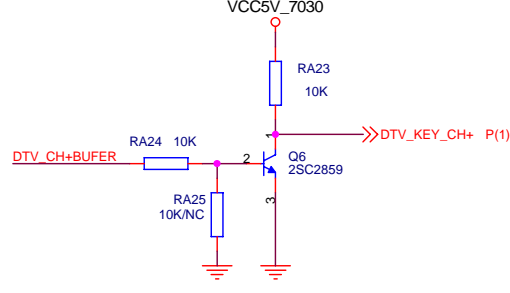

CYPRESS TECH. CO., LTD.

Title	SPV7030 - MAIN	
Size	Document Number	Rev
C	SPV7030 Part I	1.1
Date:	Friday, August 11, 2006	Sheet 6 of 13

ADC POWER/GND (3.3V)

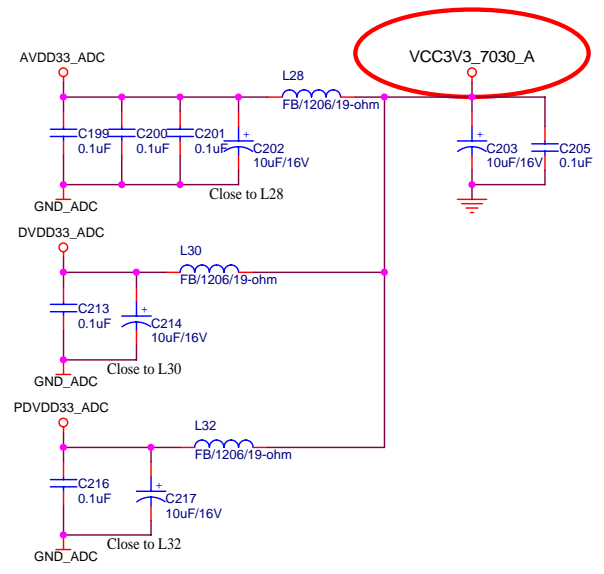

此框內的部份請靠近U12所對應的輸入處

TMDS POWER/GND (1.8V/3.3V)

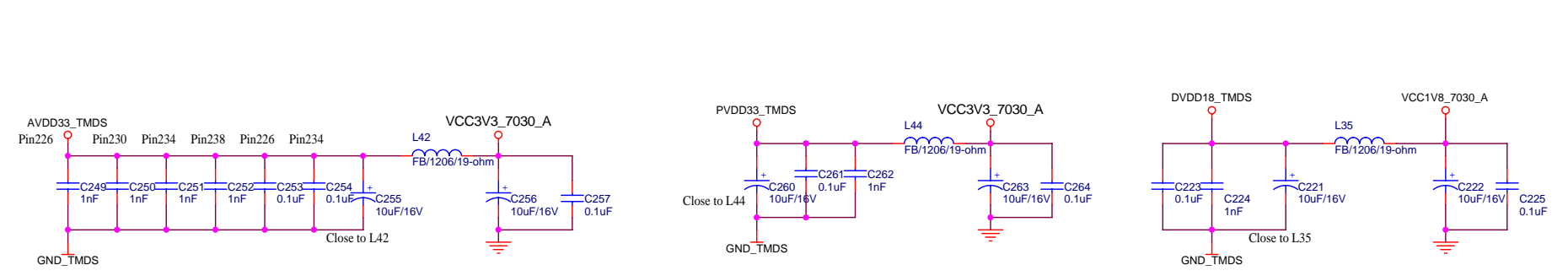

SPV7030 Power

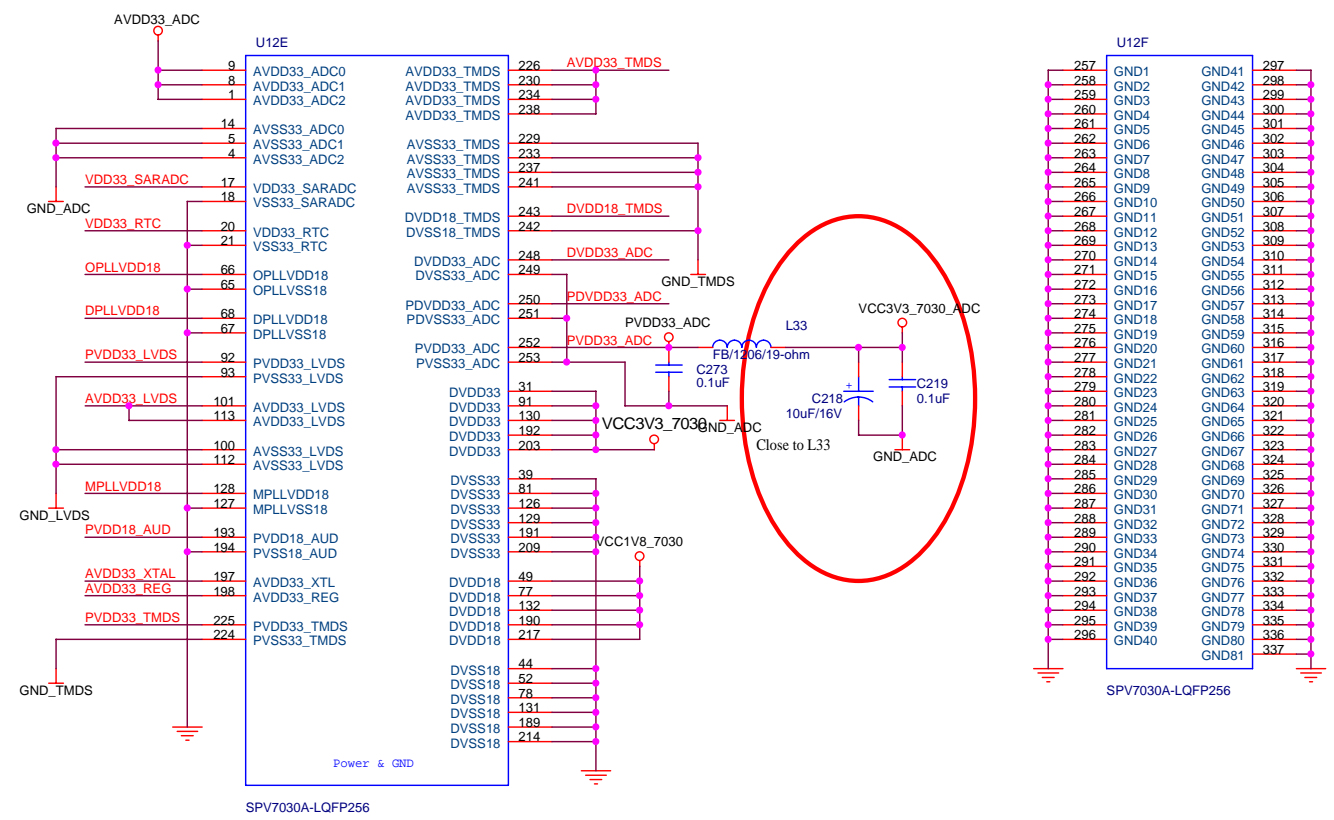

SARADC POWER/GND (3.3V)

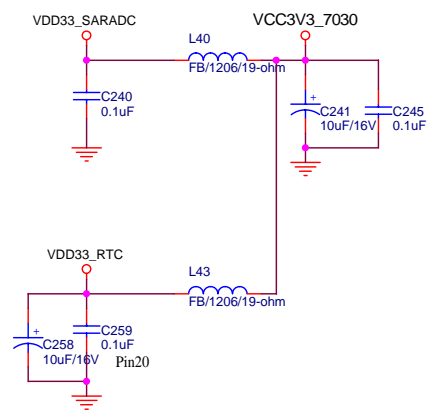

PLL POWER/GND (1.8V)

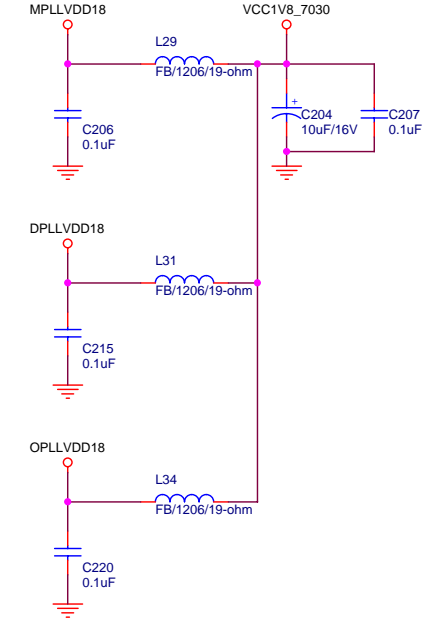

SOURCE POWER/GND (1.8V/3.3V)

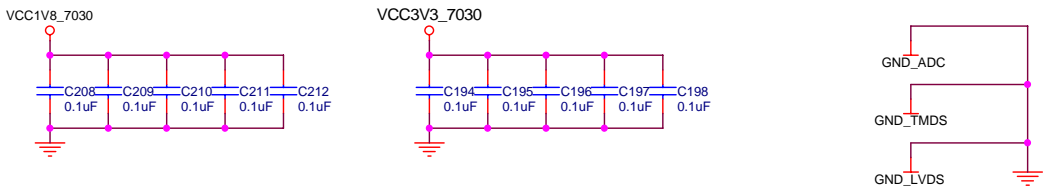

XTAL POWER/GND (3.3V)

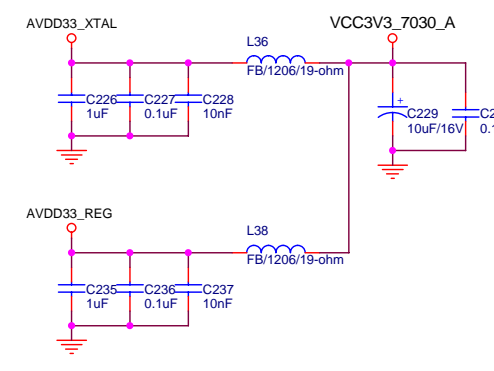

LVDS POWER/GND (3.3V)

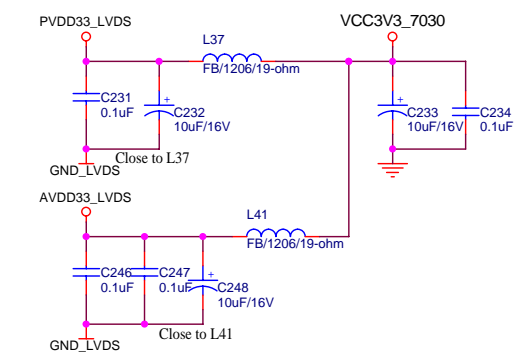

AUD POWER/GND (1.8V)

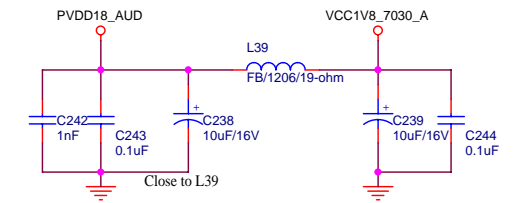

CYPRESS TECH. CO., LTD.

Title			SPV7030 - MAIN
Size	Document Number	Rev	
C	SPV7030 Part II	1.0	
Date:	Friday, August 11, 2006	Sheet	7 of 13

U13

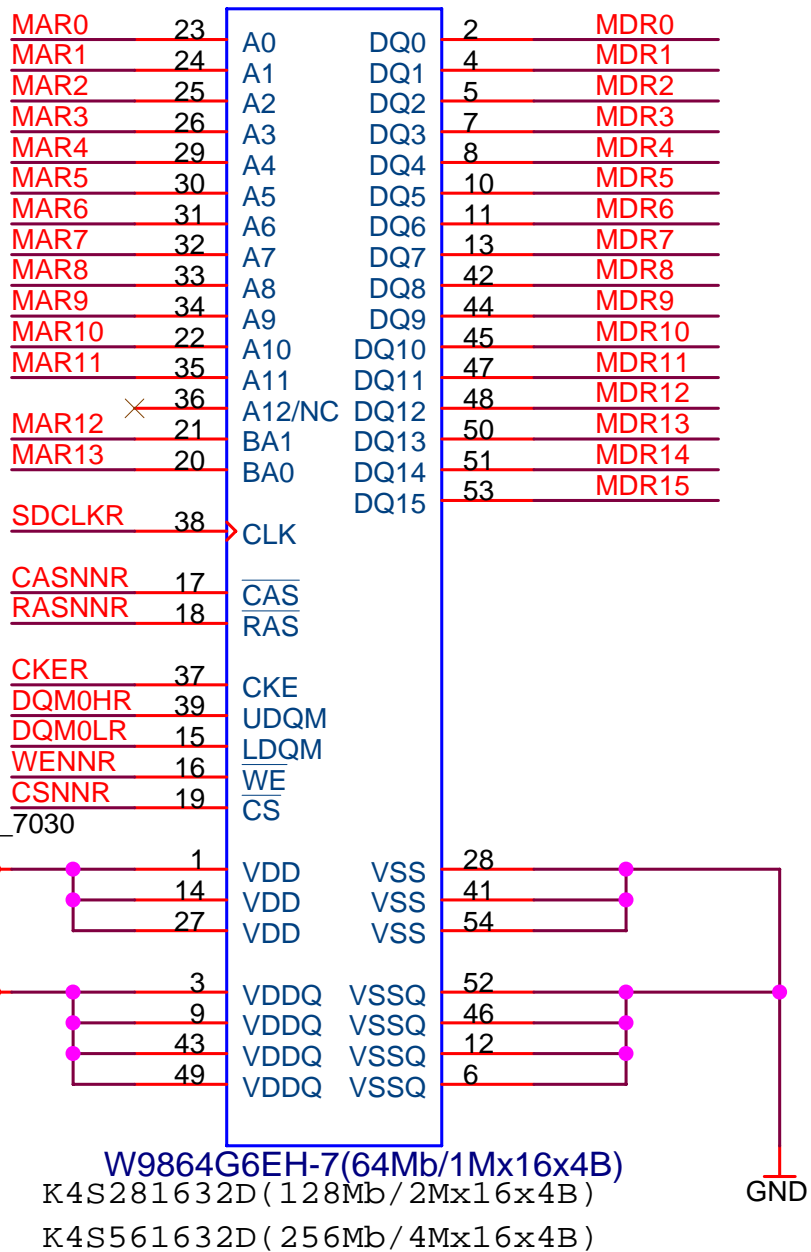

W9864G6EH-7 (64Mb/1Mx16x4B)
 K4S281632D (128Mb/2Mx16x4B)
 K4S561632D (256Mb/4Mx16x4B)

SDRAM DATA BUS

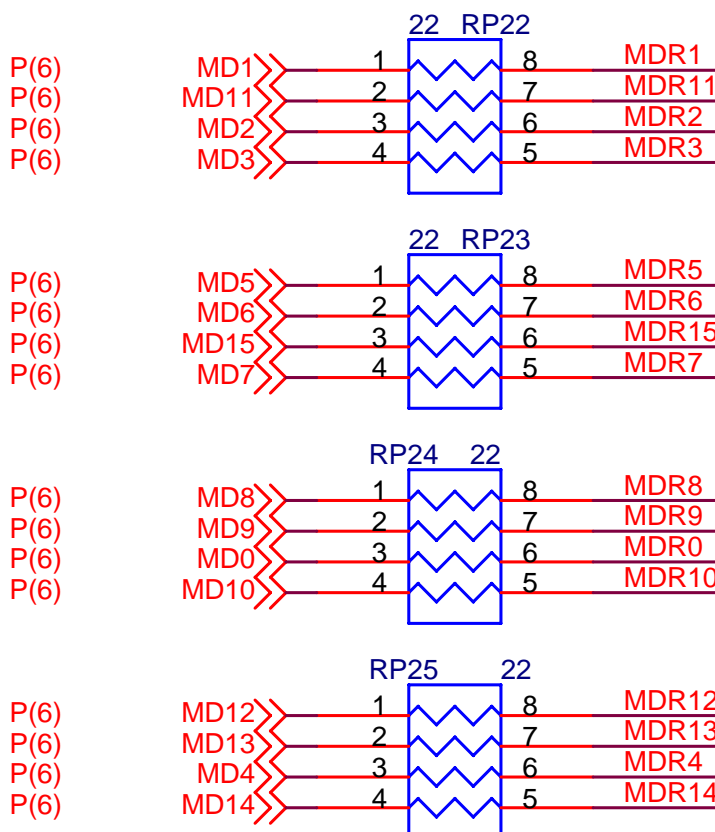

SDRAM ADDRESS BUS

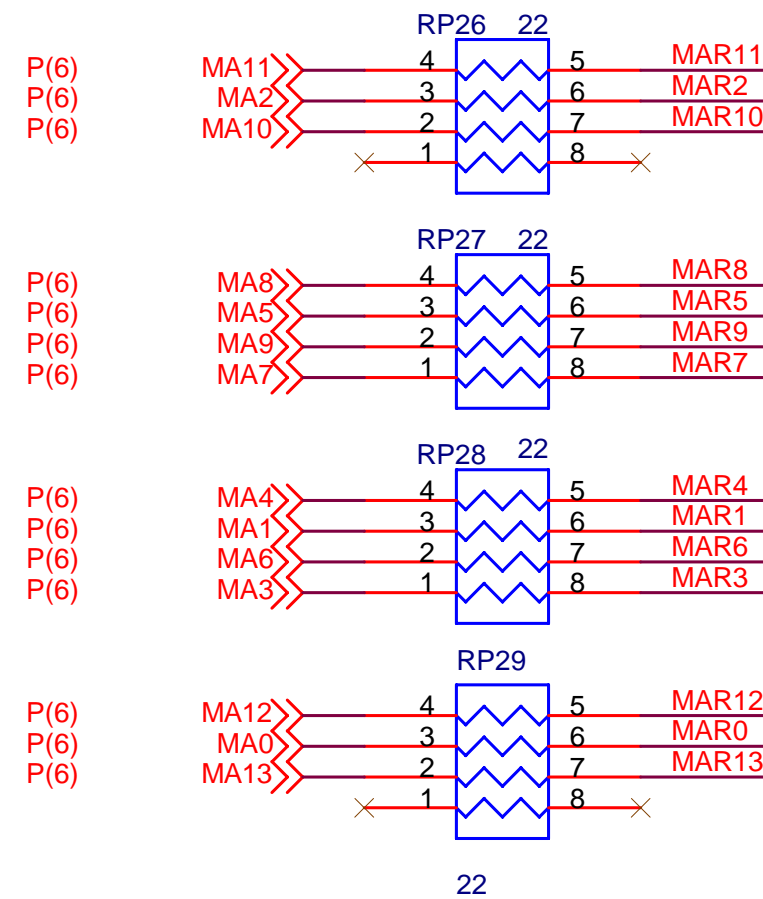

SDRAM CONTROLLER SIGNAL

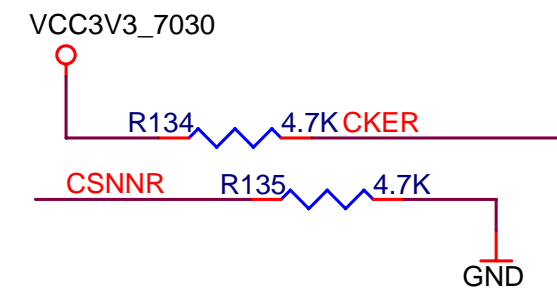
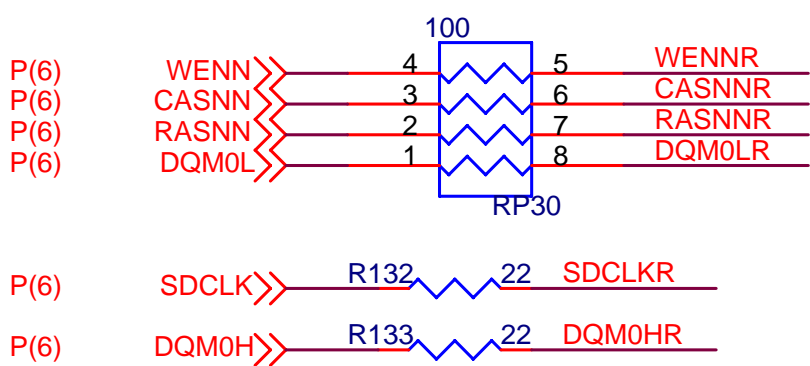

SOURCE POWER/GND (3.3V)

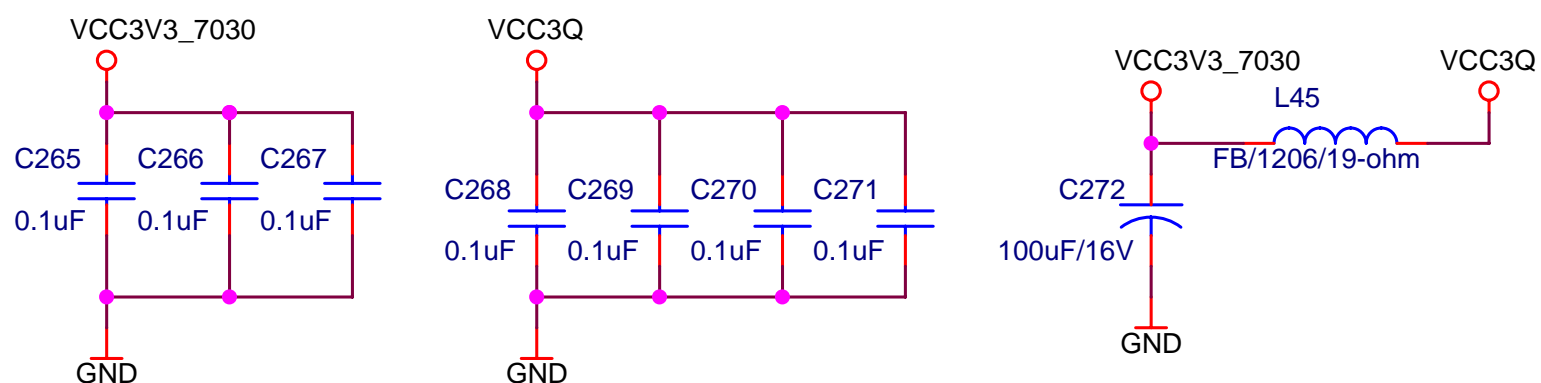

CYPRESS TECH. CO., LTD.

Title		
SPV7030 - MAIN		
Size	Document Number	Rev
A	SPV7030 SDRAM	1.1
Date:	Friday, August 11, 2006	Sheet 8 of 13

SPV7030 POWER/GND (5V/3.3V/ 1.8V)

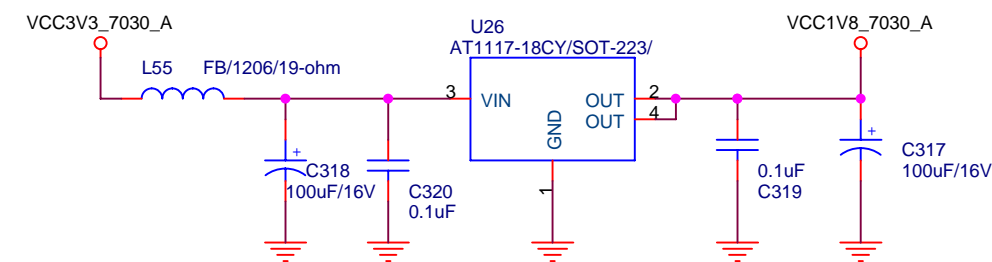
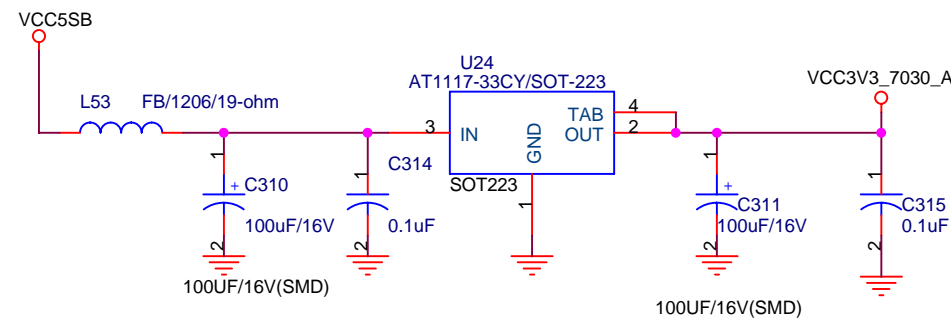
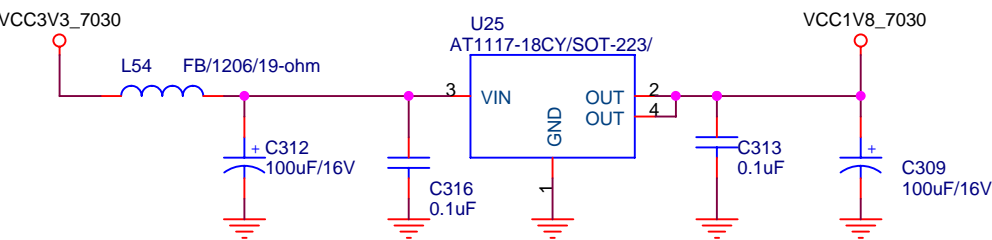
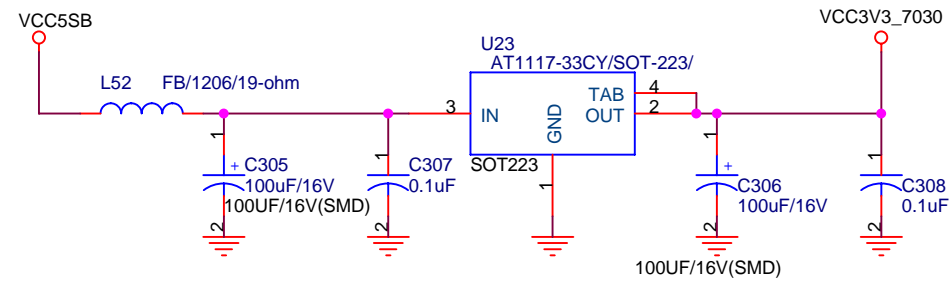
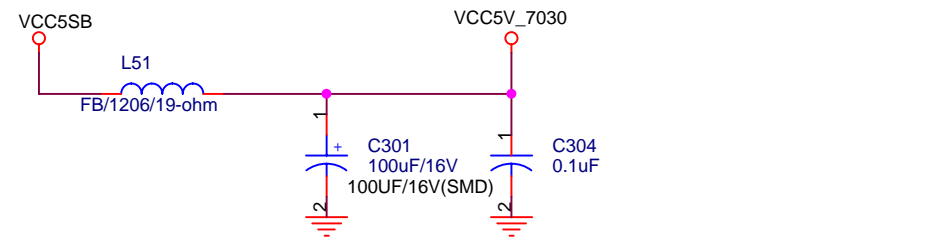

SOURCE POWER/GND (3.3V/2.5V)

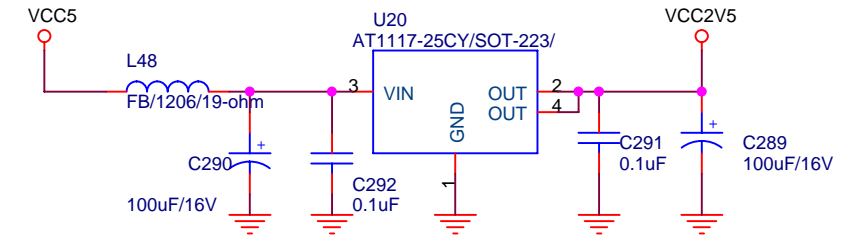
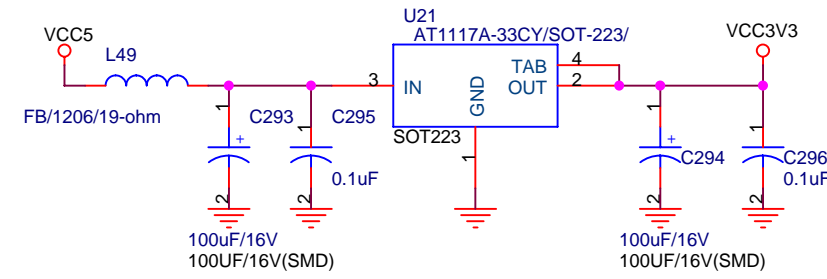

Audio POWER/GND (12V/8V/5V)

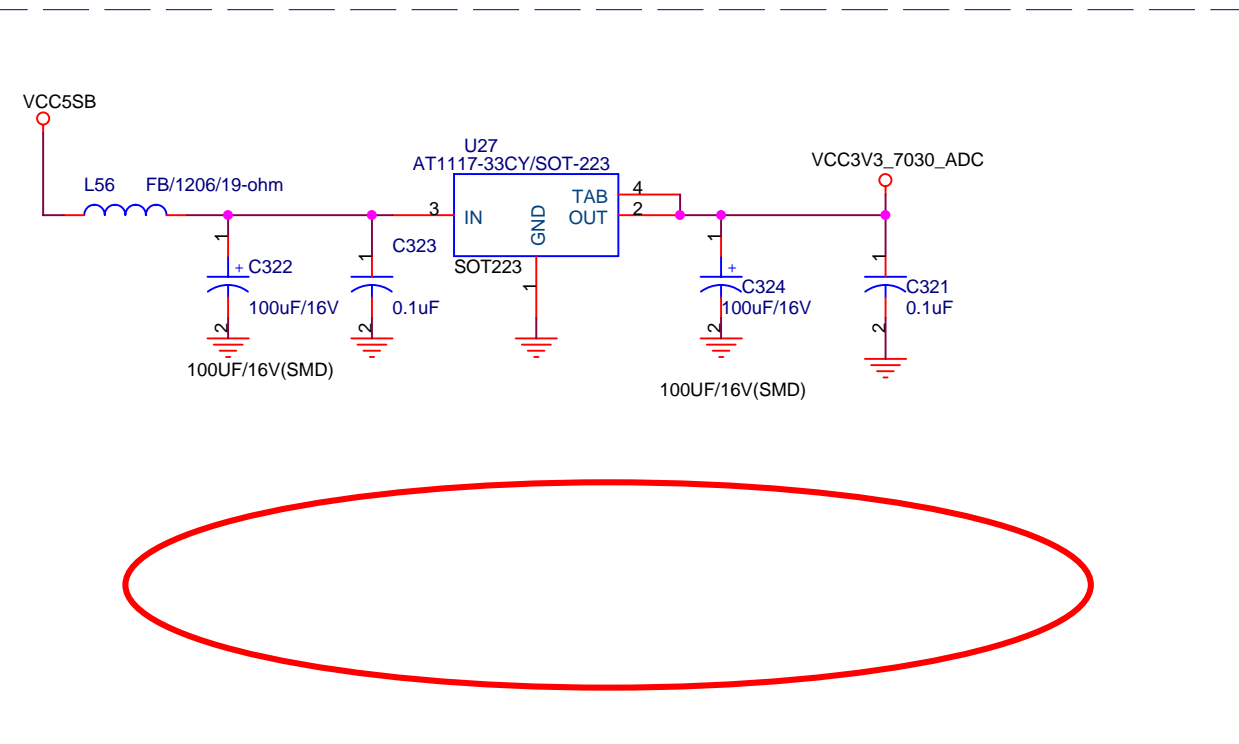
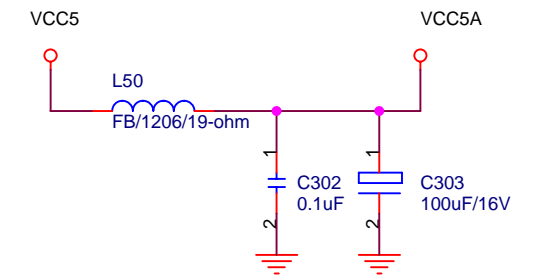
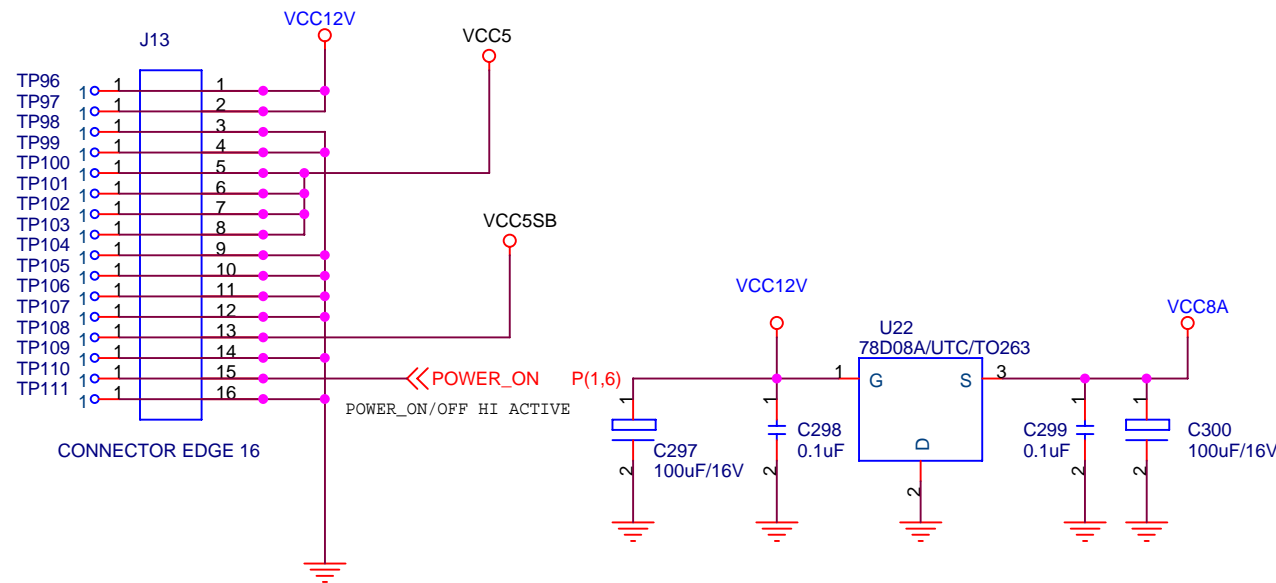

CYPRESS TECH. CO., LTD.		
Title SPV7030 - MAIN		
Size B	Document Number SPV7030 Part II	Rev 1.1
Date: Friday, August 11, 2006	Sheet 10 of 13	

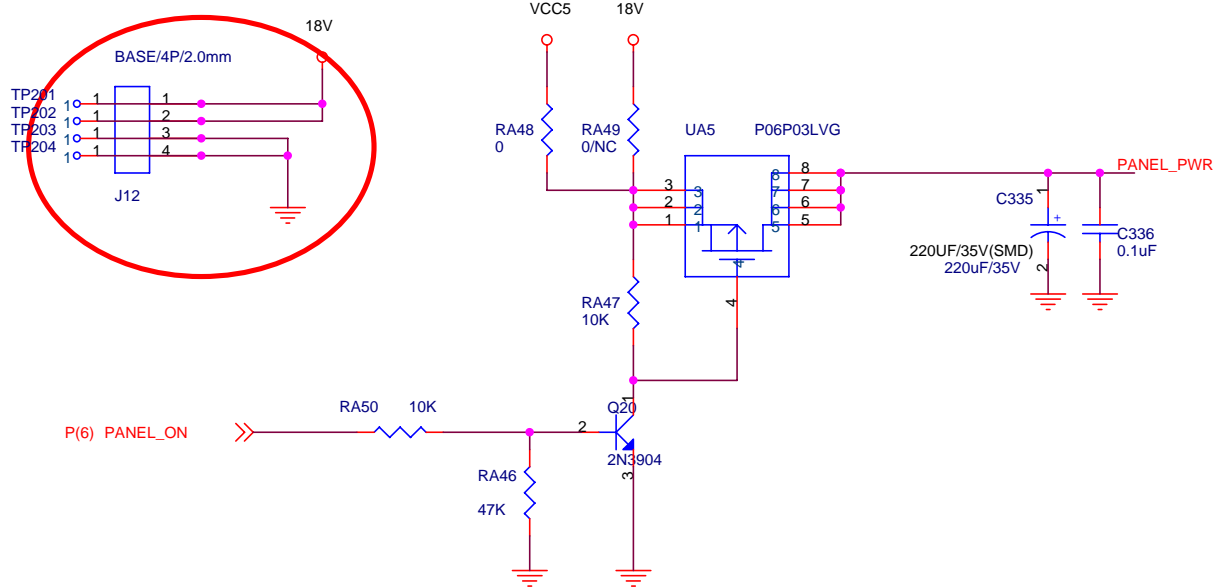

CMO 32: R231 = 3.3K, R232 = 0, VCC_Panel = 5V
 CMO 37: R231 = 12K, R232 = 1.6K, VCC_Panel = 18V

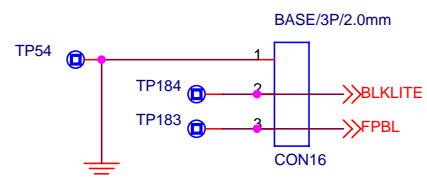

Panel Interface

layout時請加test dot

EVEN

ODD

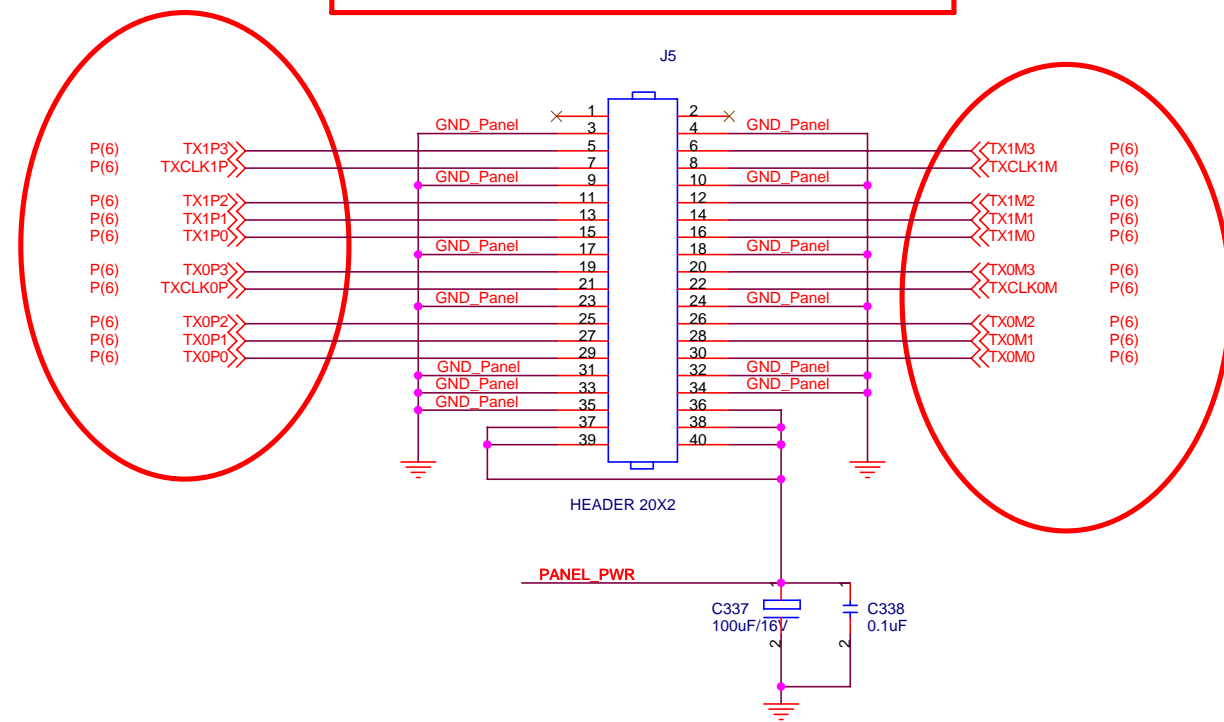

Pin17~Pin40 is for CMO32"

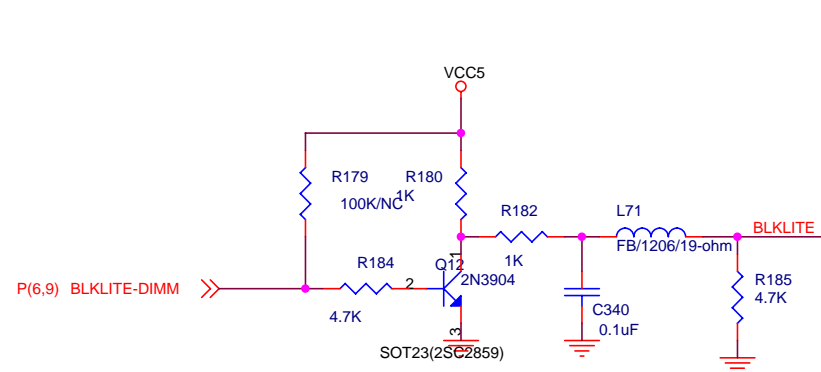

P(6) FPBIAS

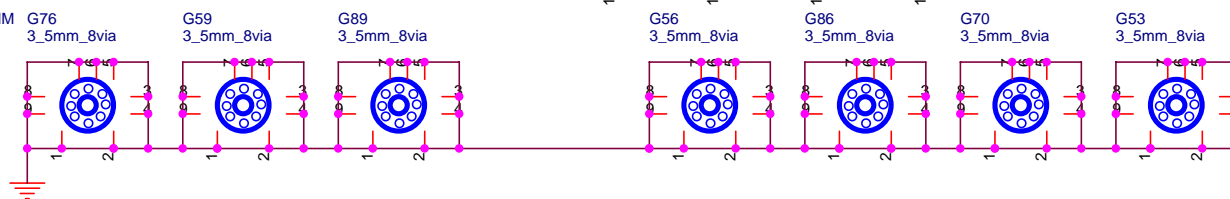
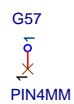
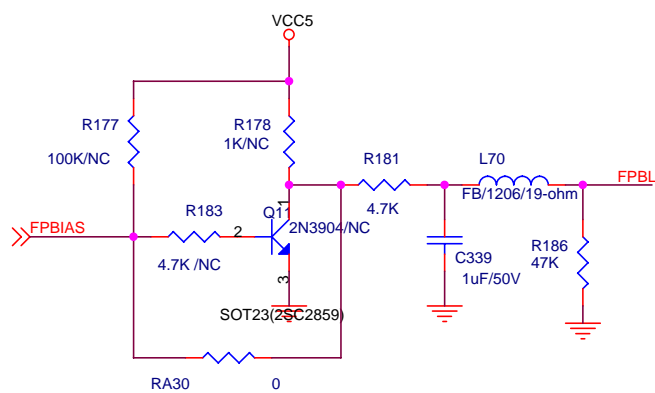

CYPRESS TECH. CO., LTD.

Title		
SPV7030 - MAIN		
Size	Document Number	Rev
Custom	Panel Output	1.1
Date:	Friday, August 11, 2006	Sheet 11 of 13

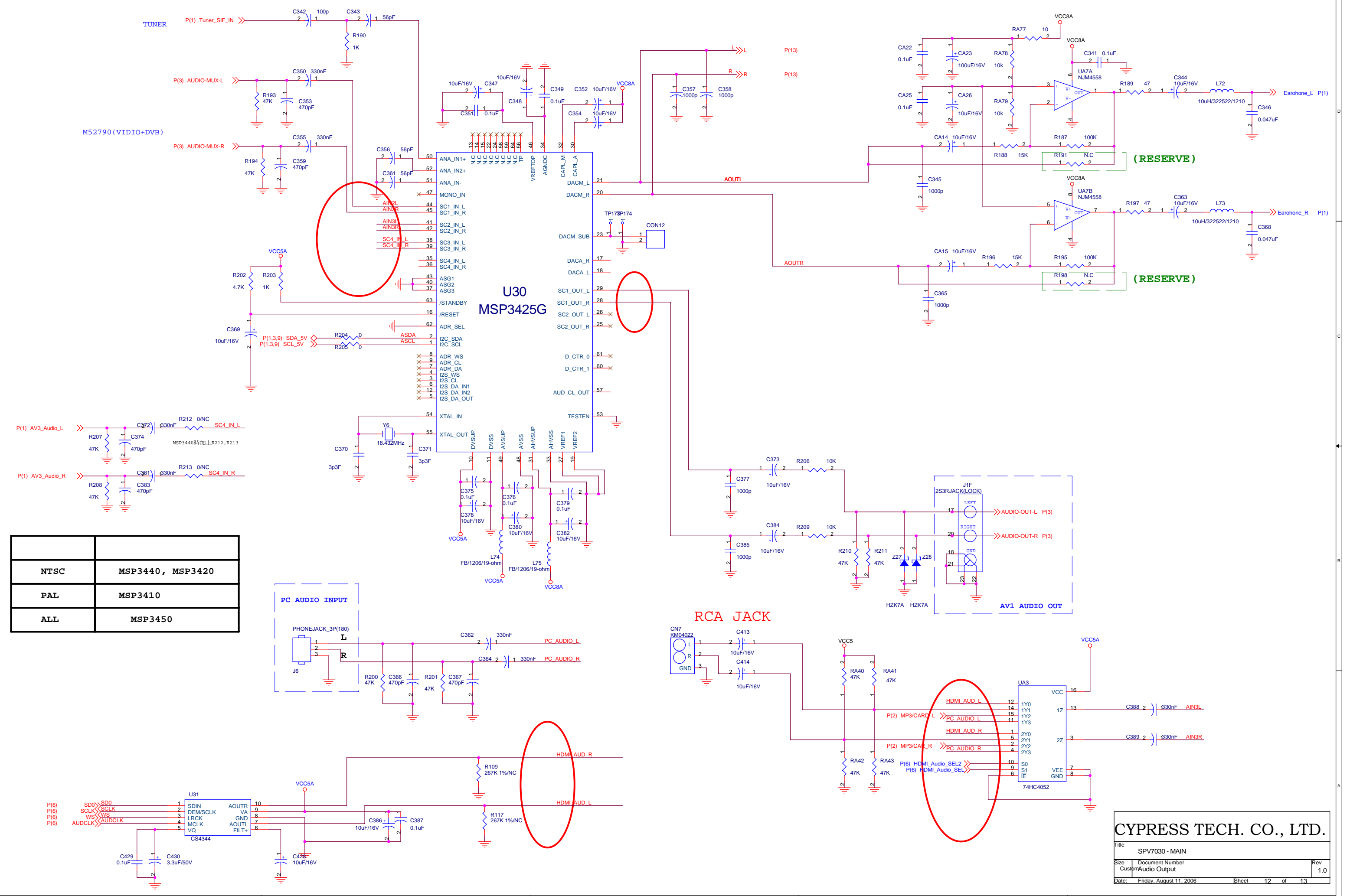

NTSC	MSP3440, MSP3420
PAL	MSP3410
ALL	MSP3450

CYPRESS TECH. CO., LTD.

File: SPV7030 - MAIN

Size	Document Number	Rev
Customer	Audio Output	1.0

Date: Friday, August 11, 2006 Sheet 12 of 13

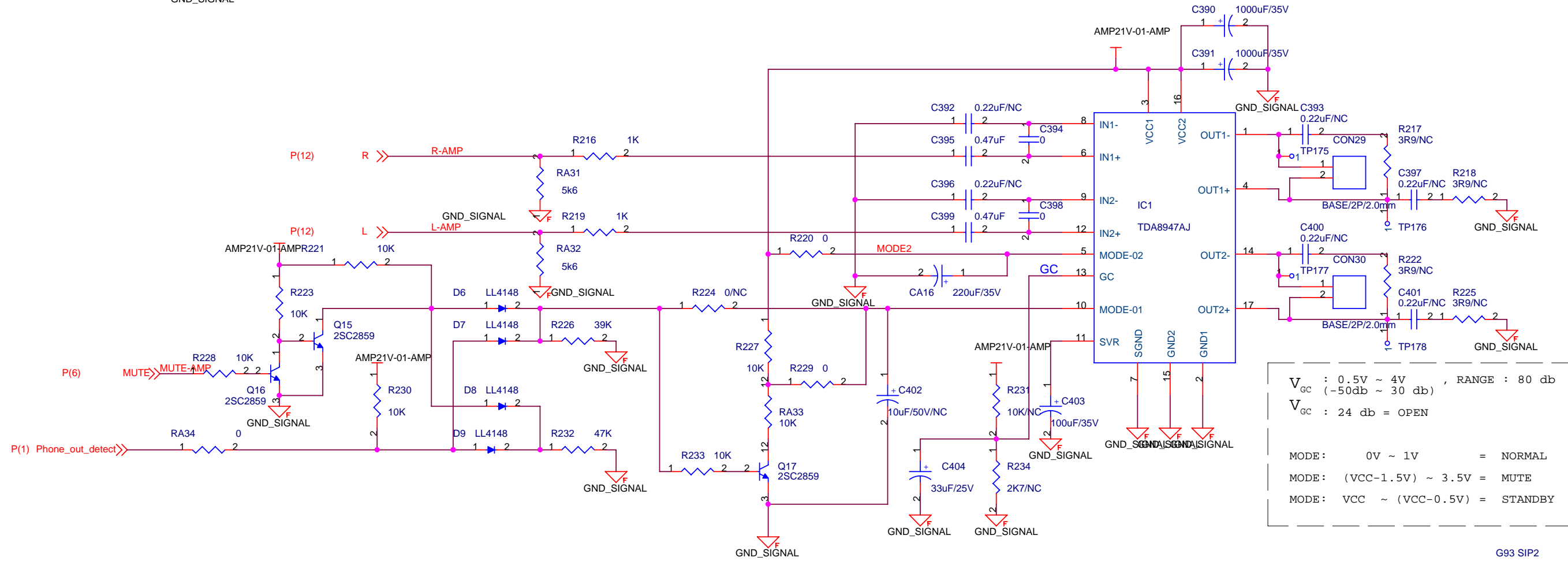
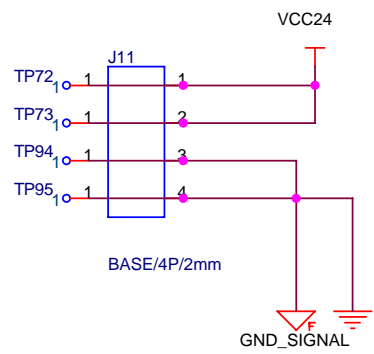

V_{gc} : 0.5V ~ 4V , RANGE : 80 db
 V_{gc} (-50db ~ 30 db)
 V_{gc} : 24 db = OPEN
 MODE : 0V ~ 1V = NORMAL
 MODE : (VCC-1.5V) ~ 3.5V = MUTE
 MODE : VCC ~ (VCC-0.5V) = STANDBY

